

**DENON**

**AVR-E400**

**INTEGRATED NETWORK AV RECEIVER**

**Owner's Manual**

## SAFETY PRECAUTIONS



**CAUTION**  
**RISK OF ELECTRIC SHOCK**  
**DO NOT OPEN**



**CAUTION:**  
**TO REDUCE THE RISK OF ELECTRIC SHOCK, DO NOT REMOVE COVER (OR BACK). NO USER-SERVICEABLE PARTS INSIDE. REFER SERVICING TO QUALIFIED SERVICE PERSONNEL.**

The lightning flash with arrowhead symbol, within an equilateral triangle, is intended to alert the user to the presence of uninsulated "dangerous voltage" within the product's enclosure that may be of sufficient magnitude to constitute a risk of electric shock to persons.

The exclamation point within an equilateral triangle is intended to alert the user to the presence of important operating and maintenance (servicing) instructions in the literature accompanying the appliance.

**WARNING:**  
**TO REDUCE THE RISK OF FIRE OR ELECTRIC SHOCK, DO NOT EXPOSE THIS APPLIANCE TO RAIN OR MOISTURE.**



**CAUTION:**  
**HOT SURFACE. DO NOT TOUCH.**

The top surface over the internal heat sink may become hot when operating this product continuously. Do not touch hot areas, especially around the "Hot surface mark" and the top panel.

# IMPORTANT SAFETY INSTRUCTIONS

1. Read these instructions.
2. Keep these instructions.
3. Heed all warnings.
4. Follow all instructions.
5. Do not use this apparatus near water.
6. Clean only with dry cloth.
7. Do not block any ventilation openings. Install in accordance with the manufacturer's instructions.
8. Do not install near any heat sources such as radiators, heat registers, stoves, or other apparatus (including amplifiers) that produce heat.
9. Do not defeat the safety purpose of the polarized or grounding-type plug. A polarized plug has two blades with one wider than the other. A grounding type plug has two blades and a third grounding prong. The wide blade or the third prong are provided for your safety. If the provided plug does not fit into your outlet, consult an electrician for replacement of the obsolete outlet.
10. Protect the power cord from being walked on or pinched particularly at plugs, convenience receptacles, and the point where they exit from the apparatus.
11. Only use attachments/accessories specified by the manufacturer.
12. Use only with the cart, stand, tripod, bracket, or table specified by the manufacturer, or sold with the apparatus. When a cart is used, use caution when moving the cart/apparatus combination to avoid injury from tip-over.
13. Unplug this apparatus during lightning storms or when unused for long periods of time.
14. Refer all servicing to qualified service personnel. Servicing is required when the apparatus has been damaged in any way, such as power-supply cord or plug is damaged, liquid has been spilled or objects have fallen into the apparatus, the apparatus has been exposed to rain or moisture, does not operate normally, or has been dropped.
15. Batteries shall not be exposed to excessive heat such as sunshine, fire or the like.



### CAUTION:

To completely disconnect this product from the mains, disconnect the plug from the wall socket outlet. The mains plug is used to completely interrupt the power supply to the unit and must be within easy access by the user.

## FCC INFORMATION (For US customers)

### 1. COMPLIANCE INFORMATION

Product Name: Integrated Network AV Receiver

Model Number: AVR-E400

This product complies with Part 15 of the FCC Rules. Operation is subject to the following two conditions: (1) this product may not cause harmful interference, and (2) this product must accept any interference received, including interference that may cause undesired operation.

Denon Electronics (USA), LLC

(a D&M Holdings Company)

100 Corporate Drive

Mahwah, NJ 07430-2041

Tel. (201) 762-6665

### 2. IMPORTANT NOTICE: DO NOT MODIFY THIS PRODUCT

This product, when installed as indicated in the instructions contained in this manual, meets FCC requirements. Modification not expressly approved by Denon may void your authority, granted by the FCC, to use the product.

### 3. IMPORTANT

When connecting this product to network hub or router, use only a shielded STP or ScTP LAN cable which is available at retailer.

Follow all installation instructions. Failure to follow instructions could void your authority, granted by the FCC, to use the product.

### 4. NOTE

This product has been tested and found to comply with the limits for a Class B digital device, pursuant to Part 15 of the FCC Rules. These limits are designed to provide reasonable protection against harmful interference in a residential installation.

This product generates, uses and can radiate radio frequency energy and, if not installed and used in accordance with the instructions, may cause harmful interference to radio communications. However, there is no guarantee that interference will not occur in a particular installation. If this product does cause harmful interference to radio or television reception, which can be determined by turning the product OFF and ON, the user is encouraged to try to correct the interference by one or more of the following measures:

- Reorient or relocate the receiving antenna.
- Increase the separation between the equipment and receiver.
- Connect the product into an outlet on a circuit different from that to which the receiver is connected.
- Consult the local retailer authorized to distribute this type of product or an experienced radio/TV technician for help.

### For Canadian customers:

This Class B digital apparatus complies with Canadian ICES-003.

## ☐ NOTES ON USE

### WARNINGS

- Avoid high temperatures.  
Allow for sufficient heat dispersion when installed in a rack.
- Handle the power cord carefully.  
Hold the plug when unplugging the cord.
- Keep the unit free from moisture, water, and dust.
- Unplug the power cord when not using the unit for long periods of time.
- Do not obstruct the ventilation holes.
- Do not let foreign objects into the unit.
- Do not let insecticides, benzene, and thinner come in contact with the unit.
- Never disassemble or modify the unit in any way.
- Ventilation should not be impeded by covering the ventilation openings with items, such as newspapers, tablecloths or curtains.
- Naked flame sources such as lighted candles should not be placed on the unit.
- Observe and follow local regulations regarding battery disposal.
- Do not expose the unit to dripping or splashing fluids.
- Do not place objects filled with liquids, such as vases, on the unit.
- Do not handle the mains cord with wet hands.
- When the switch is in the OFF (STANDBY) position, the equipment is not completely switched off from MAINS.
- The equipment shall be installed near the power supply so that the power supply is easily accessible.
- Do not keep the battery in a place exposed to direct sunlight or in places with extremely high temperatures, such as near a heater.

## ☐ CAUTIONS ON INSTALLATION

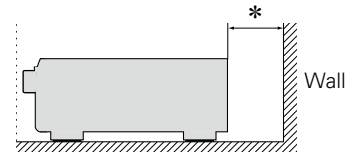
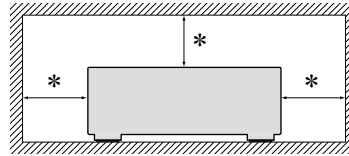

**\* For proper heat dispersal, do not install this unit in a confined space, such as a bookcase or similar enclosure.**

- More than 12 in. (0.3 m) is recommended.

# Getting started

Thank you for purchasing this Denon product. To ensure proper operation, please read this owner's manual carefully before using the product. After reading this manual, be sure to keep it for future reference.

## Contents

<b>Getting started</b> .....	<a href="#">1</a>
Accessories .....	<a href="#">2</a>
Features .....	<a href="#">2</a>
Cautions on handling .....	<a href="#">3</a>

## Basic instructions .....

[4](#)

<b>Connections</b> .....	<a href="#">5</a>
Important information .....	<a href="#">5</a>
Connecting HDMI devices .....	<a href="#">7</a>
Connecting other devices .....	<a href="#">12</a>
Connecting to a home network (LAN) .....	<a href="#">19</a>
Connecting the power cord .....	<a href="#">20</a>
<b>Setup</b> .....	<a href="#">21</a>
Set up speakers (Audyssey® Setup) .....	<a href="#">21</a>
Making the network settings (Network) .....	<a href="#">27</a>
<b>Playback (Basic operation)</b> .....	<a href="#">28</a>
Important information .....	<a href="#">28</a>
Playing a Blu-ray Disc player/DVD player .....	<a href="#">29</a>
Playing a CD player .....	<a href="#">29</a>
Playing an iPod .....	<a href="#">30</a>
Playing a USB memory device .....	<a href="#">33</a>
Listening to FM/AM broadcasts .....	<a href="#">36</a>
<b>Network content</b> .....	<a href="#">45</a>
Listening to Internet Radio .....	<a href="#">45</a>
Playing back files stored on a PC and NAS .....	<a href="#">48</a>
Using online services .....	<a href="#">52</a>
Convenient functions .....	<a href="#">63</a>
AirPlay function .....	<a href="#">69</a>
<b>Selecting a listening mode (Sound Mode)</b> .....	<a href="#">71</a>
Selecting a listening mode .....	<a href="#">71</a>

## Advanced instructions .....

[76](#)

<b>Installation/connection/setup of speakers (Advanced)</b> .....	<a href="#">77</a>
Speaker installation .....	<a href="#">77</a>
Speaker connection .....	<a href="#">79</a>
Set up speakers .....	<a href="#">86</a>
<b>Playback (Advanced operation)</b> .....	<a href="#">88</a>
HDMI control function .....	<a href="#">88</a>
Sleep timer function .....	<a href="#">89</a>
Quick select function .....	<a href="#">90</a>
Web control function .....	<a href="#">91</a>
Various memory functions .....	<a href="#">92</a>
<b>Playback in ZONE2 (Separate room)</b> .....	<a href="#">93</a>
Audio output .....	<a href="#">93</a>
Playback .....	<a href="#">93</a>
Sleep timer function .....	<a href="#">94</a>
<b>How to make detailed settings</b> .....	<a href="#">95</a>
Menu map .....	<a href="#">95</a>
Examples of menu screen displays .....	<a href="#">97</a>
Examples of menu and front display .....	<a href="#">98</a>
Inputting characters .....	<a href="#">99</a>
Audio .....	<a href="#">100</a>
Video .....	<a href="#">106</a>
Inputs .....	<a href="#">111</a>
Speakers .....	<a href="#">115</a>
Network .....	<a href="#">119</a>
General .....	<a href="#">123</a>

## Information .....

[129](#)

<b>Part names and functions</b> .....	<a href="#">130</a>
Front panel .....	<a href="#">130</a>
Display .....	<a href="#">131</a>
Rear panel .....	<a href="#">132</a>
Remote control unit .....	<a href="#">133</a>
<b>Other information</b> .....	<a href="#">135</a>
Trademark information .....	<a href="#">135</a>
Surround .....	<a href="#">136</a>
Relationship between video signals and monitor output .....	<a href="#">140</a>
Explanation of terms .....	<a href="#">142</a>
<b>Troubleshooting</b> .....	<a href="#">145</a>
Resetting the microprocessor .....	<a href="#">149</a>
<b>Specifications</b> .....	<a href="#">149</a>



## Accessories

Check that the following parts are supplied with the product.

① Getting Started .....	1
② CD-ROM (Owner's Manual) .....	1
③ Safety Instructions .....	1
④ Warranty (for North America model only).....	1
⑤ Remote control unit (RC-1183).....	1
⑥ R03/AAA batteries.....	2
⑦ AM loop antenna .....	1
⑧ FM indoor antenna .....	1
⑨ Setup and measurement microphone.....	1
(ACM1HB)	
⑩ Cable Label.....	1

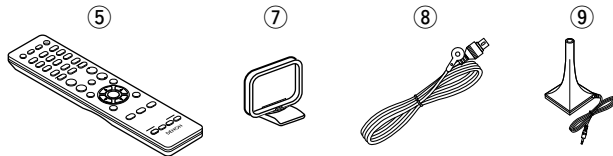

## Features

### Digital video processor upscales analog video signals (SD resolution) to HD (720p/1080p) and 4K

This unit features a sophisticated video processor that can upscale standard definition (SD) analog video content from legacy sources such as a VCR to HD and is able to output at 4K resolution (3840 x 2160 pixels) for compatibility with newly available resolution 4K TVs.

### With discrete circuit technology, the power amplifier provides identical quality for all 7 channels (125 Watts x 7 channels)

For optimum realism and stunning dynamic range, the power amplifier section features discrete power devices (not integrated circuitry).

By using high current, high power discrete power devices, the amplifier is able to easily drive high quality speakers.

### Supports Internet Radio, music, and photograph streaming

#### Supports AirPlay® (👉 page 69)

You can enjoy a wide variety of content, including listening to Internet Radio, playing audio files stored on your PC, and displaying photographs stored on your PC on our television.

This unit also supports Apple AirPlay which lets you stream your music library from an iPhone®, iPad®, iPod touch® or iTunes®.

### Compatible with “Denon Remote App” for performing basic operations of the unit with an iPad, iPhone\* or Android smartphone

“Denon Remote App” is application software that allows you to perform basic operations with an iPad, iPhone, Android smartphone or Android tablet such as turning the unit ON/OFF, controlling the volume, and switching the source.

\* Download the appropriate “Denon Remote App” for iOS and Android devices. This unit needs to be connected to your LAN and the iPhone/iPod touch or other device needs to be connected to the same network by Wi-Fi (wireless LAN).

### “Setup Assistant” provides easy-to-follow setup instructions

First select the language when prompted. Then simply follow the instructions displayed on the TV screen to set up the speakers, network, etc.

### Easy to use Graphical User Interface

This unit is equipped with an easy to see Graphical User Interface that uses menu displays and features colorful icons and easy to understand controls for maximum ease of use.

### HDMI connections enable quick connection to various digital AV devices (6 inputs, 1 output)

The unit is equipped with 6 HDMI input connectors for connecting devices with HDMI connectors, such as a Blu-ray Disc player, game console, HD digital camcorder, HDTVs, etc.

### Supports HDMI (3D, ARC, Deep Color, “x.v.Color”, Auto Lip Sync, 4K) and HDMI control function (👉 page 7)

Advanced HDMI features are supported, including 3D passthrough, Audio Return Channel, Auto Lip Sync, Deep Color and “x.v.Color”, and HDMI CEC control functions. If a 4K digital video signal is input, it is passed through the unit unchanged, and the GUI overlay will adjust the resolution accordingly.

### Direct play for iPod and iPhone via USB (👉 page 16)

Music data from an iPod or iPhone can be played back if you connect the USB cable supplied with the iPod via the USB port of this unit, and also an iPod can be controlled with the remote control that comes with this unit.

### Multi-Room audio

Enjoy audio playback in your home theater and another room at the same time.

## Cautions on handling

- **Before turning the power on**

Check once again that all connections are correct and that there are no problems with the connection cables.

- Power is supplied to some of the circuitry even when the unit is set to the standby mode. When going on vacation or leaving home for long periods of time, be sure to unplug the power cord from the power outlet.

- **About condensation**

If there is a major difference in temperature between the inside of the unit and the surroundings, condensation (dew) may form on the operating parts inside the unit, causing the unit not to operate properly.

If this happens, let the unit sit for an hour or two with the power turned off and wait until there is little difference in temperature before using the unit.

- **Cautions on using mobile phones**

Using a mobile phone near this unit may result in noise. If that occurs, move the mobile phone away from this unit when it is in use.

- **Moving the unit**

Turn off the power and unplug the power cord from the power outlet. Next, disconnect the connection cables to other system units before moving the unit.





- **About care**

- Wipe the cabinet and control panel clean with a soft cloth.
- Follow the instructions when using a chemical cleaner.
- Benzene, paint thinner or other organic solvents as well as insecticide may cause material changes and discoloration if brought into contact with the unit, and should therefore not be used.

## Basic instructions

---

Here we explain the connections and basic operation methods for this unit.

- **Connections**  [page 5](#)
- **Setup**  [page 21](#)
- **Playback (Basic operation)**  [page 28](#)
- **Network content**  [page 45](#)
- **Selecting a listening mode (Sound Mode)**  [page 71](#)

For speaker connections, see [page 79](#).















# Connections

## Important information

Make connections before using this unit.



















To create a home theater that can play back higher quality video and audio by fully utilizing the capabilities of this unit and your video devices, connect this unit to each of your video devices with HDMI cables.

### □ HDMI devices

 TV  <a href="#">page 9</a>	 CBL/SAT  <a href="#">page 10</a>	 DVD  <a href="#">page 10</a>
 Blu-ray  <a href="#">page 10</a>	 GAME  <a href="#">page 10</a>	 MEDIA PLAYER  <a href="#">page 10</a>
 AUX  <a href="#">page 10</a>		

If your video device does not support HDMI connections, use the following connection.



### □ Other devices

 TV  <a href="#">page 13</a>	 CBL/SAT  <a href="#">page 14</a>	 DVD  <a href="#">page 15</a>
 iPod/USB  <a href="#">page 16</a>	 CD  <a href="#">page 17</a>	 TUNER  <a href="#">page 18</a>
 NETWORK  <a href="#">page 19</a>	 SPEAKER  <a href="#">page 79</a>	 AC IN  <a href="#">page 20</a>

This unit can change the source that is assigned to the DIGITAL AUDIO IN, ANALOG AUDIO IN, COMPONENT VIDEO IN and VIDEO IN connectors.

For details on assigning a source to connectors, see “Changing the source assigned to connectors” ( [page 12](#)). For the setting method, see “Input Assign” ( [page 112](#)).

### NOTE

- Do not plug in the power cord until all connections have been completed. However, when the “Setup Assistant” is running, follow the instructions in the “Setup Assistant” ( [page 7](#)) screen for making connections. (During “Setup Assistant” operation, the input/output connectors do not conduct current.)
- When running the “Setup Assistant” ( [page 7](#)), turn off the power supply of connected devices.
- When making connections, also refer to the operating instructions of the other devices being connected.
- Be sure to connect the left and right channels properly (left with left, right with right).
- Do not bundle power cords together with connection cables. Doing so can result in noise.

## Converting input video signals for HD output (Video conversion function)

This unit is equipped with three types of video input connectors (HDMI, component video and composite video) and one type of video output connector (HDMI).

This function automatically converts various formats of video signals input to this unit into the formats used to output the video signals from this unit to a monitor.

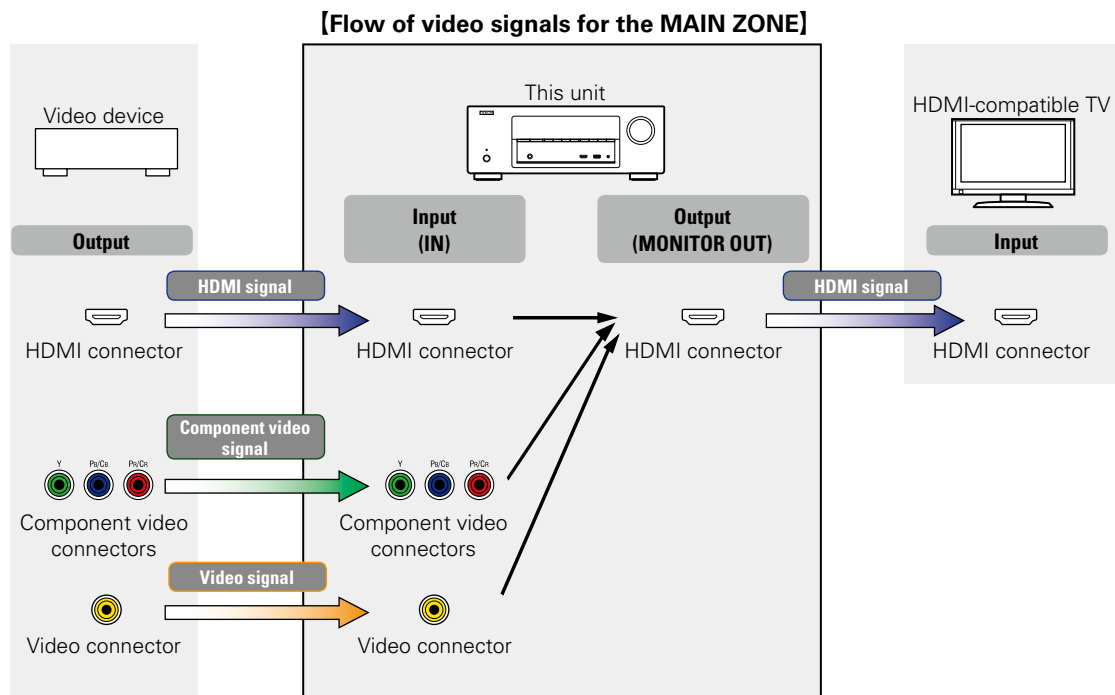

For maximum flexibility with different video signal types and resolutions, this unit provides two important video processing functions. First, it can convert standard definition composite video to digital HDMI. It also provides video upscaling from standard definition to high definition resolutions, supporting 720p and 1080p HD outputs via HDMI, including 4K. If you have older legacy video sources such as a VCR and/or an analog video camcorder, connect via the composite video connectors (yellow jacks). If you have an older DVD or HD player that is not equipped with HDMI output but is equipped with component output, connect the player to the unit's component video input. Pay attention to the component video connection (it's a three wire connection) so as to ensure that the jacks on the player match the component video input jacks on this unit, otherwise you may not see a picture, or the picture will have distorted colors.

### Make Settings as Necessary

- If you do not want this unit to convert video signals automatically, use the following setting item to disable this function.  
**"Video Conversion"** ([page 108](#))
- If you want to change the resolution of video signals output to the TV, use the following setting item to do so.  
**"Resolution"** ([page 109](#))



- The video conversion function supports the NTSC, PAL, SECAM, NTSC 4.43, PAL-N, PAL-M and PAL-60 formats.
- Resolutions of HDMI-compatible TVs can be checked at "Video" – "HDMI Monitor" ([page 126](#)).

### NOTE

When a non-standard video signal from a game console or some other source is input, the video conversion function might not operate.

## Connecting HDMI devices

You can connect up to seven HDMI-compatible devices (6-inputs/1-output) to the unit.

If the device connected to this unit is equipped with an HDMI connector, it is recommended to use HDMI connections. Connections with an HDMI cable offer the following benefits that can not be achieved with other connection methods.

- **High quality playback by transmitting audio and video via digital signals**

HDMI connections can transmit high definition video and high quality audio formats adopted by Blu-ray disc players (Dolby Digital Plus, Dolby TrueHD, dts-HD, dts-HD Master Audio).

HDMI connections also convey information required for playback between devices. The information is used for copyright protection and TV resolution recognition, the ARC function, the HDMI control function, etc.

- **Transmission of audio and video signals with a single HDMI cable**

Previous connections required multiple audio and video cables, but HDMI connections require only a single HDMI cable to transmit audio and video signals. This allows wires in a home theater system, which tend to be complicated, to be more easily organized.

- **Mutual control through the HDMI control function** (👉 [page 88](#))

This unit and the HDMI device connected via HDMI can be linked to perform operations such as power control, volume control, and input source switching.

- **Other video and audio functions, such as 3D video playback, Content Type, the ARC function, are supported** (👉 [page 11](#)).



- There is more than one version of the HDMI standard. The supported functions and the performance vary according to the version. This unit complies with the HDMI standard that supports the ARC and 3D playback functions. To enjoy these functions, the HDMI device connected to this unit also needs to use the same version of the standard. For the version of the HDMI standard on the device connected to this unit, see the device's manual.
- Some TVs do not support audio input via HDMI connections. For details, see your TV's manual.

❑ **Before connecting this unit to TV via HDMI connections** (👉 [page 8](#))

❑ **Connecting this unit to a TV via HDMI connections** (👉 [page 9](#))

❑ **Connecting this unit to video devices via HDMI connections** (👉 [page 10](#))

❑ **HDMI function** (👉 [page 11](#))

❑ **Settings related to HDMI connections** (👉 [page 11](#))

## Before connecting this unit to TV via HDMI connections

There are 2 methods to connect an HDMI-compatible TV to this unit.  
Use the connection method that suits your TV.

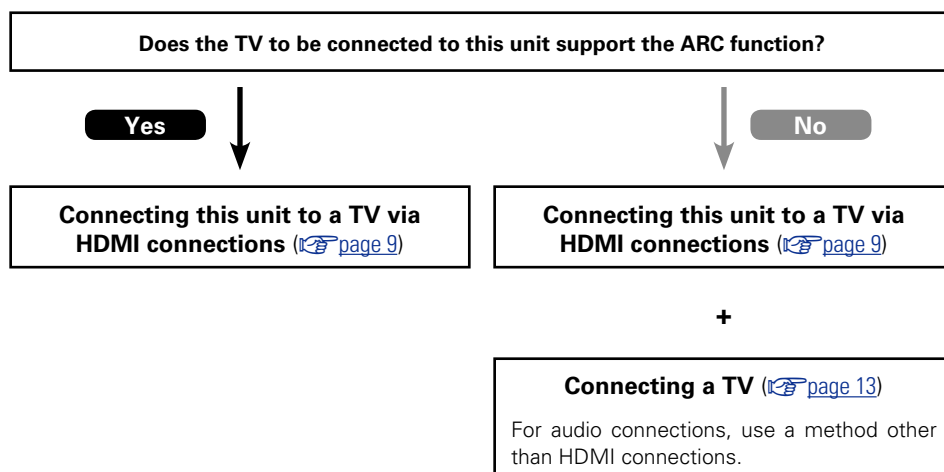

## About ARC (Audio Return Channel) function

This function plays TV audio on this unit by sending the TV audio signal to this unit via the HDMI cable. If a TV without the ARC function is connected via HDMI connections, video signals of the playback device connected to this unit are transmitted to the TV, but this unit can not play back the audio from the TV. If you want to enjoy surround audio for TV program, a separate audio cable connection is required.

In contrast, if a TV with the ARC function is connected via HDMI connections, no audio cable connection is required. Audio signals from the TV can be input to this unit through the HDMI cable between this unit and the TV. This function allows you to enjoy surround playback on this unit for the TV.



When the ARC function is used, connect a device with a "Standard HDMI cable with Ethernet" or "High Speed HDMI cable with Ethernet" for HDMI. Refer to the owner's manual for your TV for details about TV connection and settings.

### [Connection to a TV with the ARC function]

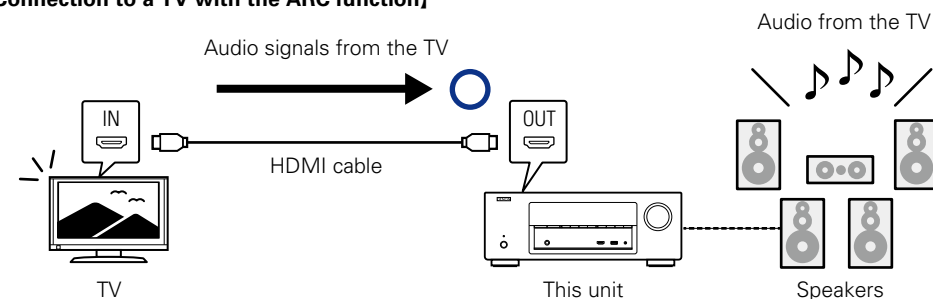

### [Connection to a TV without the ARC function]

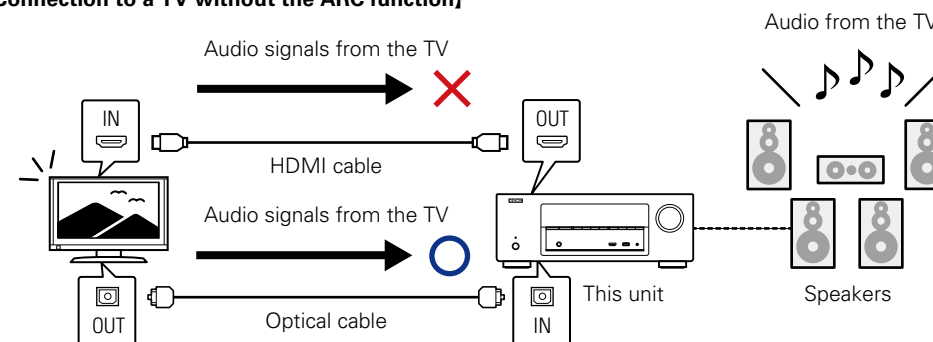

## Connecting this unit to a TV via HDMI connections

### Cables used for connections

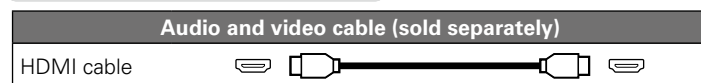

- This interface allows transfer of digital video signals and digital audio signals over a single HDMI cable.

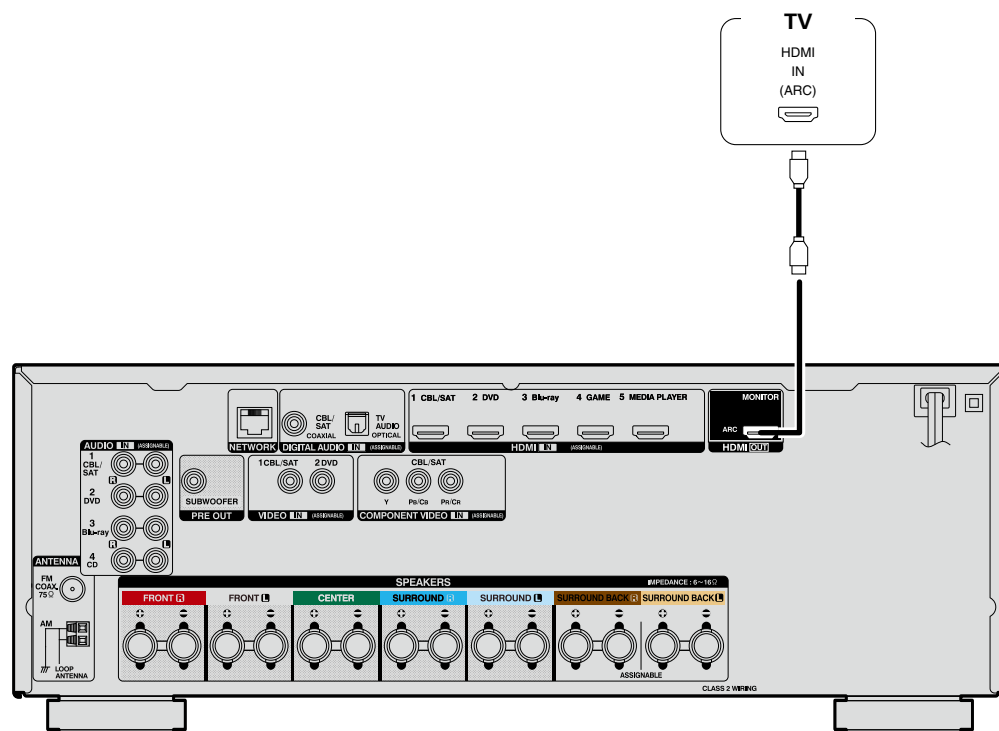

- Video signals are not output if the input video signals do not match the display's resolution. In this case, switch the Blu-ray Disc/DVD player's resolution to a resolution with which the display is compatible.
- When this unit and monitor are connected with an HDMI cable, if the display or monitor is not compatible with HDMI audio signal playback, only the video signals are sent to the display or monitor.
- To listen to TV audio through this device, use the optical digital connection.

### NOTE

- The audio signal from the HDMI output connector (sampling frequency, number of channels, etc.) may be limited by the HDMI audio specifications of the connected device regarding permissible inputs.
- When connecting a TV that does not support the ARC function, an audio cable connection is required in addition to the HDMI cable. In this case, refer to "Connecting a TV" (page 13) for the connection method.**

**For the ARC function, see "About ARC (Audio Return Channel) function" (page 8).**

### Connecting to a device equipped with a DVI-D connector

The DVI-D (Digital Visual Interface) method is also used for video transmission via digital signals. This is developed mainly for computers, and some displays such as projectors are equipped with this interface. To output HDMI video signals to a DVI-D video input compatible device, use an HDMI/DVI conversion cable or adapter.

The DVI-D connector can transmit high quality digital video signals, but copy guard and other issues may hinder normal operations for some device combinations.

### NOTE

- No sound is output when connected to a device equipped with a DVI-D connector. Make audio connections as described in "Connecting a TV" (page 13).
- Signals cannot be output to DVI-D devices that do not support HDCP.
- Depending on the combination of devices, the video signals may not be output.

### Settings required when using a TV that supports the ARC function

When using a TV that supports the ARC function, make the following settings.

- Set "HDMI Control" (page 108) to "On".



## Connecting this unit to video devices via HDMI connections

### Cables used for connections

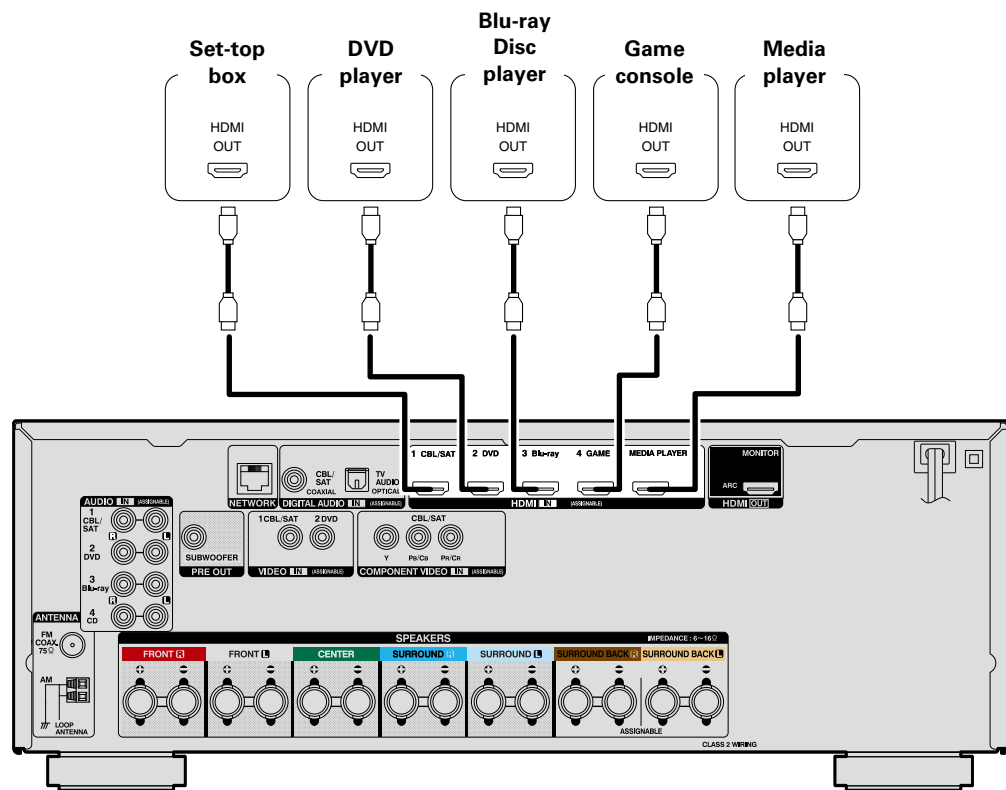
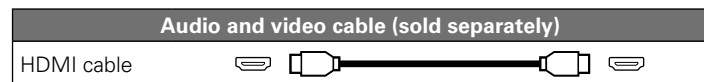

[Rear panel]

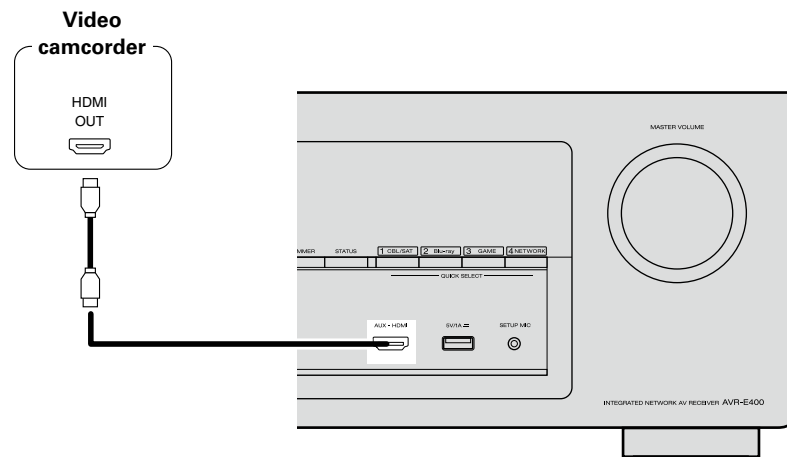

[Front panel]



- When connecting a device that supports Deep Color or 4K, please use a “High Speed HDMI cable” or “High Speed HDMI cable with Ethernet”.
- Video signals are not output if the input video signals do not match the display’s resolution. In this case, switch the Blu-ray Disc/DVD player’s resolution to a resolution with which the display is compatible.

## HDMI function

This unit supports the following HDMI functions:

### □ About 3D function

This unit supports input and output of 3D (3 dimensional) video signals of HDMI.

To play back 3D video, you need a TV and player that provide support for the HDMI 3D function and a pair of 3D glasses.

#### NOTE

- When playing back 3D video, refer to the instructions provided in the manual of your playback device together with this manual.
- When playing back 3D video content, the menu screen or status display screen can be superimposed over the image. However, the menu screen or status display screen cannot be superimposed over certain 3D video content.
- If 3D video with no 3D information is input, the menu screen and status display on this unit are displayed over the playback video.
- If 2D video is converted to 3D video on the television, the menu screen and status display on this unit are not displayed correctly. To view the menu screen and status display on this unit correctly, turn the television setting that converts 2D video to 3D video off.

### □ About 4K function

This unit supports input and output of 4K (3840 x 2160 pixels) video signals over HDMI.



When a device supporting 4K is connected, use a cable compatible with "High Speed HDMI cable" or "High Speed HDMI cable with Ethernet".

### □ HDMI pass through function (page 107)

Signals input to the HDMI input connector are output to the television or other device connected to the HDMI output connector, even if the power of this unit is in standby.

### □ HDMI control function (page 88)

This function allows you to operate external devices from the unit and operate the unit from external devices.

#### NOTE

- The HDMI control function may not work depending on the device it is connected to and its settings.
- You cannot operate a TV or Blu-ray Disc player/DVD player that is not compatible with the HDMI control function.

### □ About Content Type

This function was added with the HDMI standard. It automatically makes settings suitable for the video-output type (content information).

#### NOTE

To enable the Content Type, set "Video Mode" to "Auto" (page 108).

### □ Deep Color (page 142)

When a device supporting Deep Color is connected (such as an HD camcorder), use a cable compatible with "High Speed HDMI cable" or "High Speed HDMI cable with Ethernet".

### □ Auto Lip Sync (page 107, 142)

### □ "x.v.Color", sYCC601 color, Adobe RGB color, Adobe YCC601 color (page 142, 143)

### □ High definition digital audio format

### □ ARC (Audio Return Channel) (page 8)

#### Copyright protection system

In order to play back digital video and audio such as BD-Video or DVD-Video via HDMI connection, both this unit and TV or the player need to support the copyright protection system known as HDCP (High-bandwidth Digital Content Protection System). HDCP is copyright protection technology comprised of data encryption and authentication of the connected AV devices. This unit supports HDCP.

- If a device that does not support HDCP is connected, video and audio are not output correctly. Read the owner's manual of your television or player for more information.

## Settings related to HDMI connections

Set as necessary. For details, see the respective reference pages.

### □ HDMI Setup (page 107)

Make settings for HDMI video/audio output.

- Auto Lip Sync
- HDMI Pass Through
- HDMI Audio Out
- HDMI Control
- Pass Through Source
- Power Off Control

#### NOTE

To output audio signals that are input from the HDMI input connector to a TV connected via HDMI, set "HDMI Audio Out" (page 107) to "TV".















Audio signals input via the Analog/Coaxial/Optical input connectors cannot be output from the HDMI MONITOR output connector.

## Connecting other devices







For highest quality video and surround playback, it is recommended to use an HDMI cable to connect this unit to TV and other video devices (see [page 7](#) "Connecting HDMI devices").

This section describes alternate connection methods when your device does not support HDMI connections.

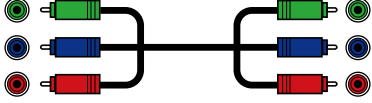
### Connection methods for various devices

 TV	 <a href="#">page 13</a>	 CBL/SAT	 <a href="#">page 14</a>
 DVD	 <a href="#">page 15</a>	 iPod/USB	 <a href="#">page 16</a>
 CD	 <a href="#">page 17</a>	 TUNER	 <a href="#">page 18</a>
 NETWORK	 <a href="#">page 19</a>		

### Cables used for connections

Video cable (sold separately)	
Component video cable	
Video cable	
Audio cable (sold separately)	
Coaxial digital cable	
Optical cable	
Audio cable	
Cable (sold separately)	
Ethernet cable	

### Changing the source assigned to connectors

This unit can change the source that is assigned to the HDMI IN, DIGITAL AUDIO IN, COMPONENT VIDEO IN, VIDEO IN and AUDIO IN connectors.

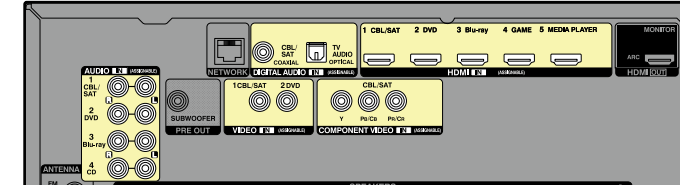

Let us take a digital audio connection for Blu-ray Disc players for an example. The rear panel digital audio input connectors do not have the input connector indication for Blu-ray disc players (Blu-ray). However, DIGITAL AUDIO IN connectors have the "ASSIGNABLE" indication, which means that you can change the source assigned to these connectors. You can assign Blu-ray disc players to these connectors to use them for Blu-ray disc players. Select "Blu-ray" when switching functions on this unit to play back the source connected to these connectors.

#### How to change the source assigned to connectors ([page 112](#))

## Connecting a TV

- This section describes how to connect when your TV does not support ARC (Audio Return Channel). For instructions on HDMI connections, see “Connecting this unit to a TV via HDMI connections” ([page 9](#)).
- To listen to TV audio through this unit, use the optical digital connection.

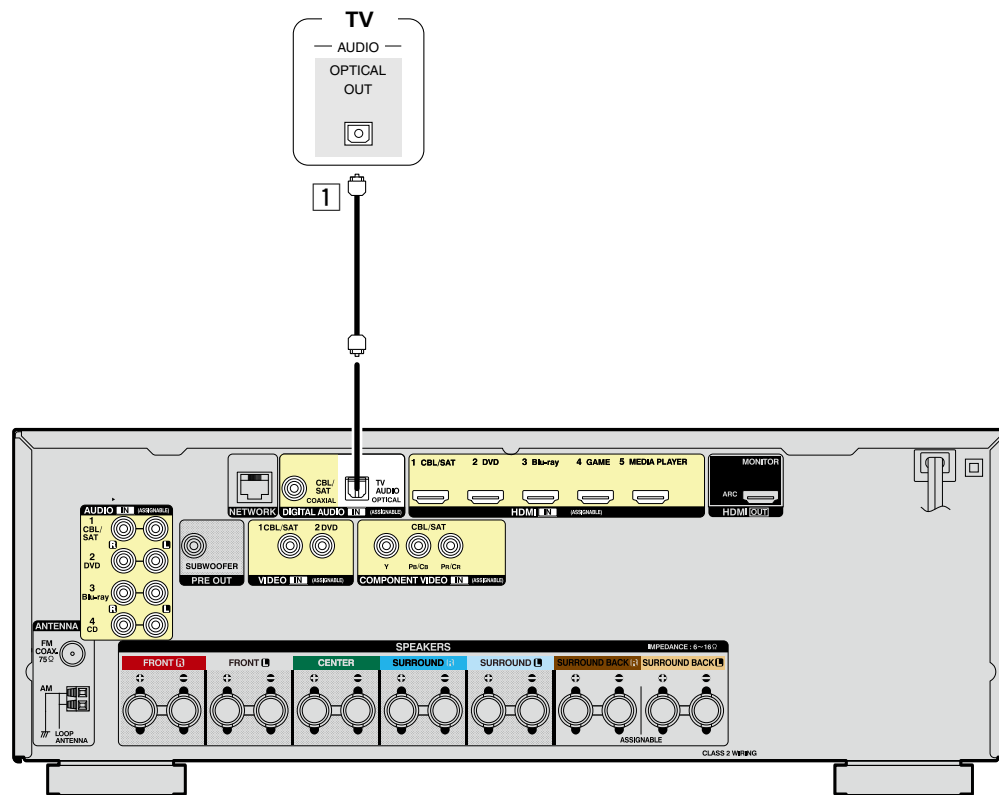

## Audio connection

The following methods are available for connecting to this unit.

### 1 DIGITAL AUDIO OPTICAL connector

When a multichannel audio (digital bit stream audio) is input, this unit decodes the audio to play back surround sound.

The        sections in the connection diagram are also available for connections. To connect devices to these connectors, you must set up input connectors. For details, see “Input Assign” ([page 112](#)).

## Connecting a set-top box (Satellite tuner/cable TV)

This section describes how to connect when your satellite tuner or cable TV does not support HDMI connections.

For instructions on HDMI connections, see “Connecting HDMI devices” ([page 7](#)).

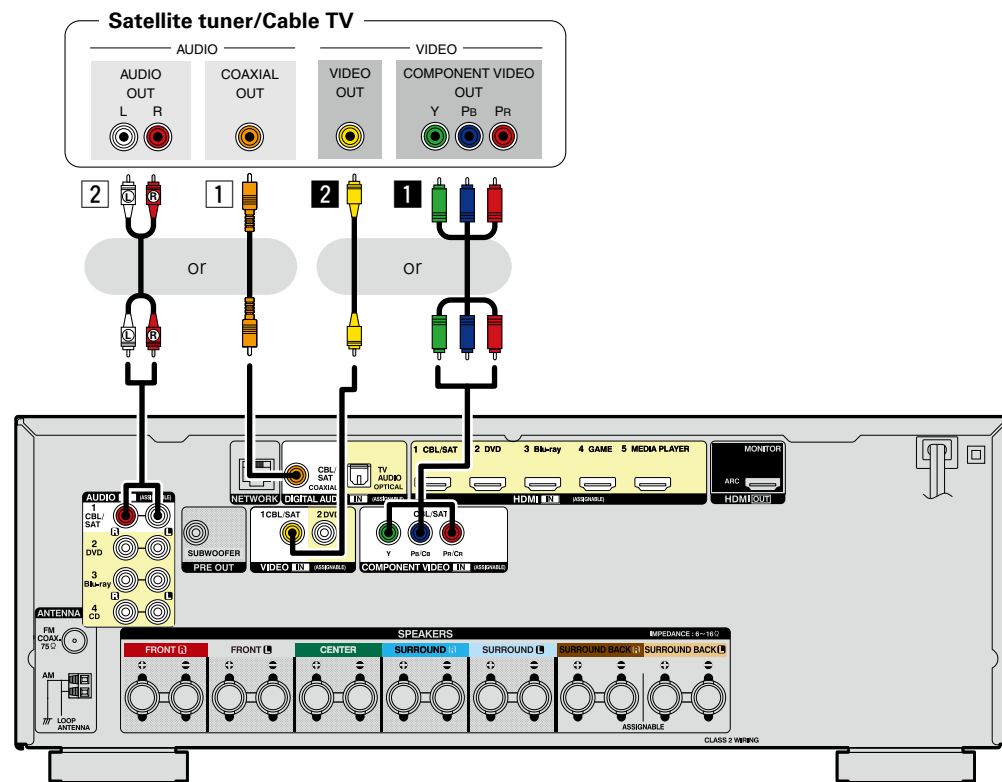

### Audio connection

The following methods are available for connecting to this unit. **Use either of the methods to make a connection.**

The numbers prefixed with connectors indicate the recommendation order. The smaller the number is, the higher playback quality is achieved.

#### 1 DIGITAL AUDIO COAXIAL connector

When a multichannel audio (digital bit stream audio) is input, this unit decodes the audio to play back surround sound.

#### 2 AUDIO IN (CBL/SAT) connector

This makes an analog audio connection.

### Video connection

The following methods are available for connecting to this unit. **Use either of the methods to make a connection.**

The numbers prefixed with connectors indicate the recommendation order. The smaller the number is, the higher playback quality is achieved.

#### 1 COMPONENT VIDEO IN (CBL/SAT) connector

This makes an analog video connection. This connection method separates video signals into 3 signals for transmission based on color components, achieving the best quality video playback among analog video connections, with less signal degradation.

#### 2 VIDEO IN (CBL/SAT) connector

This makes an analog video connection.

The      sections in the connection diagram are also available for connections. To connect devices to these connectors, you must set up input connectors. For details, see “Input Assign” ([page 112](#)).

## Connecting a DVD player

This section describes how to connect a DVD player that does not support HDMI connections. For instructions on HDMI connections, see “Connecting HDMI devices” ([page 7](#)).

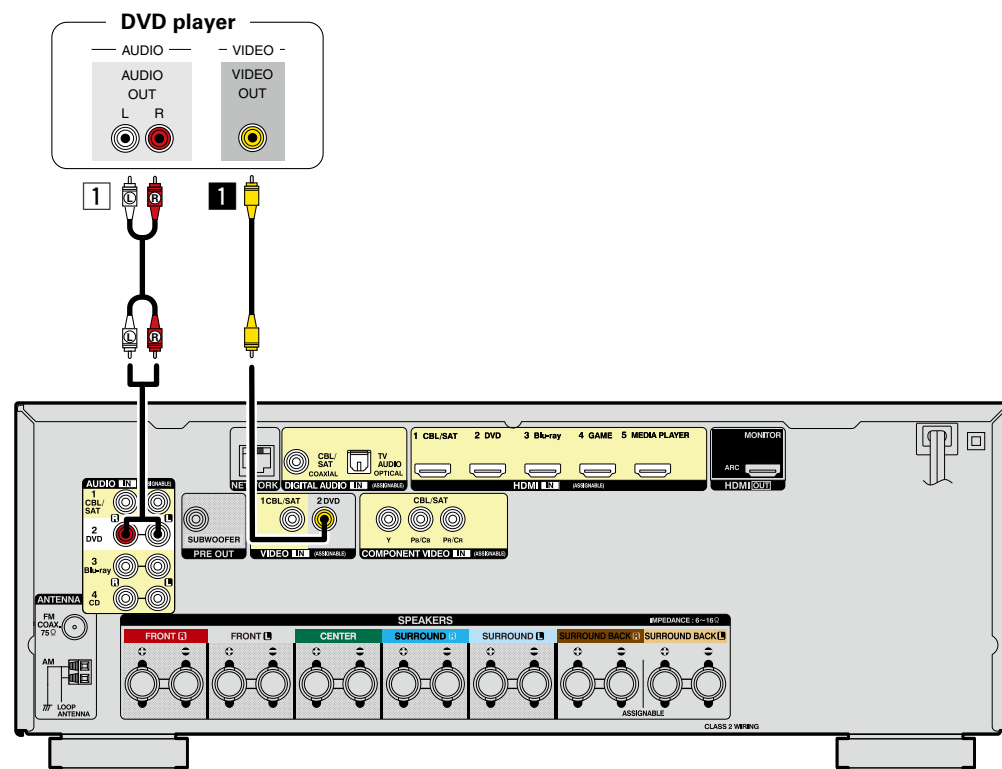

### Audio connection

The following methods are available for connecting to this unit.

#### 1 AUDIO IN (DVD) connector

This makes an analog audio connection. This type of connection converts digital audio to analog audio, so the output audio may be degraded compared to connections 1.

### Video connection

The following methods are available for connecting to this unit.

#### 1 VIDEO IN (DVD) connector

This makes an analog video connection.

The sections in the connection diagram are also available for connections. To connect devices to these connectors, you must set up input connectors. For details, see “Input Assign” ([page 112](#)).

## Connecting an iPod or USB memory device to the USB port

- You can enjoy music stored on an iPod or USB memory device.
- For operating instructions see “Playing an iPod” (page 30) or “Playing a USB memory device” (page 33).

### Cables used for connections

To connect an iPod to this unit, use the USB adapter cable that was supplied with the iPod.

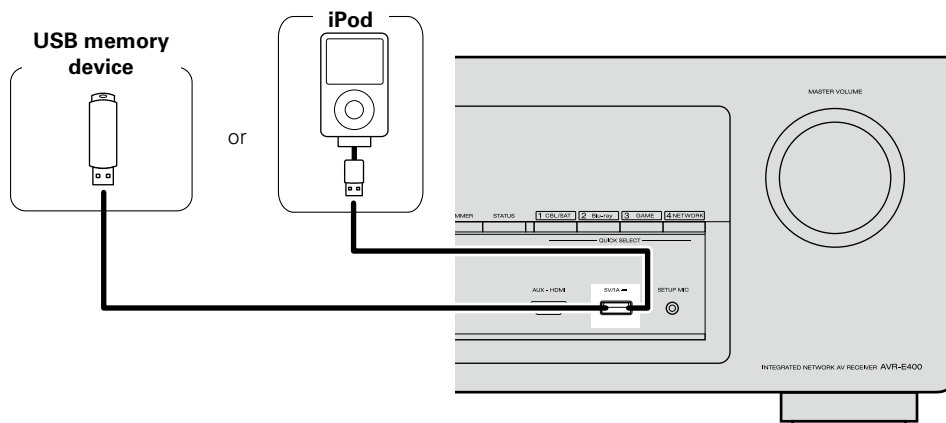

Denon does not guarantee that all USB memory devices will operate or receive power. When using a portable USB hard disk drive (HDD) which came with an AC adapter, use that device's supplied AC adapter.

### NOTE

- USB memory devices will not work via a USB hub.
- It is not possible to use this unit by connecting the unit's USB port to a PC via a USB cable.
- Do not use an extension cable when connecting a USB memory device. This may cause radio interference with other devices.
- When connecting an iPhone to this unit, keep the iPhone at least 20 cm (8 inches) away from this unit. If the iPhone is positioned close to this unit and a telephone call is received, noise may be output from this unit.
- If the iPod is connected using an iPod cable (commercially available) that is longer than 2 meters (6 feet) sound may not be played correctly. In this case, use a genuine iPod cable, or a cable that is shorter than 1 meter (3 feet).

## Supported iPod models

### • iPod classic



iPod classic  
80GB



iPod classic  
160GB (2007)



iPod classic  
160GB (2009)

### • iPod nano



iPod nano  
3rd generation  
(video)  
4GB 8GB



iPod nano  
4th generation (video)  
8GB 16GB



iPod nano  
5th generation (video camera)  
8GB 16GB



iPod nano  
6th generation  
8GB 16GB



iPod nano  
7th generation  
16GB

### • iPod touch



iPod touch  
1st generation  
8GB 16GB 32GB



iPod touch  
2nd generation  
8GB 16GB 32GB



iPod touch  
3rd generation  
32GB 64GB



iPod touch  
4th generation  
8GB 32GB 64GB



iPod touch  
5th generation  
32GB 64GB

### • iPhone



iPhone  
4G 8GB 16GB



iPhone 3G  
8GB 16GB



iPhone 3GS  
8GB 16GB 32GB



iPhone 4  
8GB 16GB 32GB



iPhone 4S  
16GB 32GB 64GB



iPhone 5  
16GB 32GB 64GB

## Connecting a CD player

You can enjoy CD sound with the player connected by digital or analog cables.

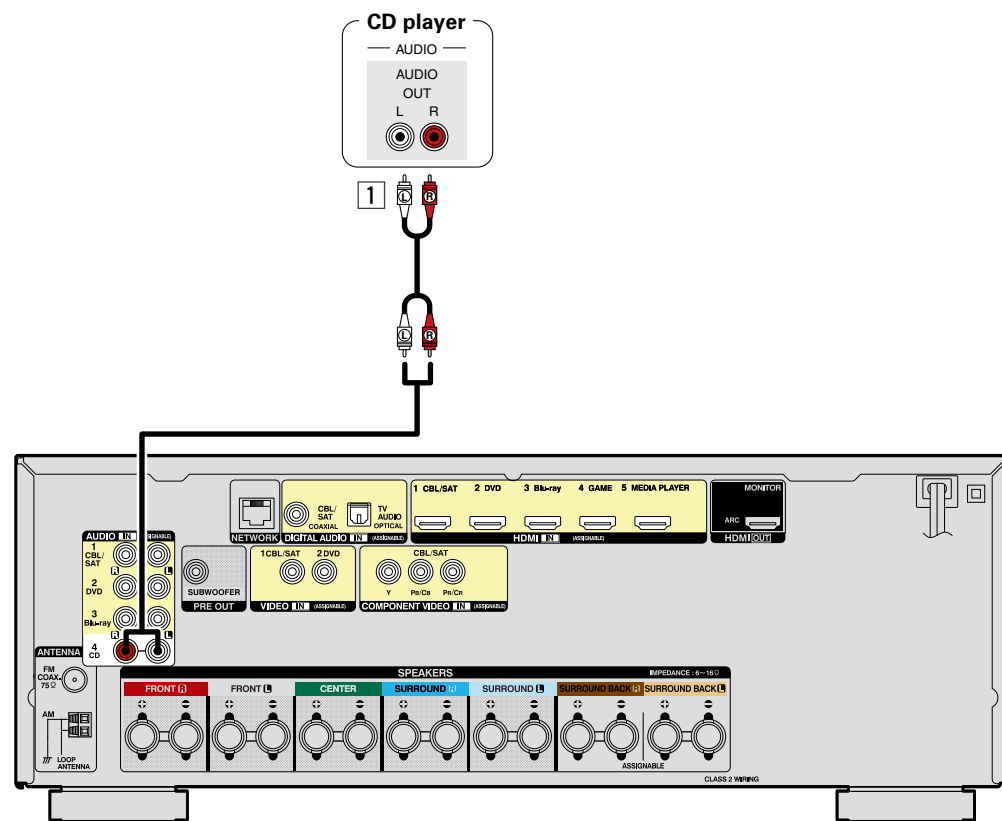

## Audio connection

The following methods are available for connecting to this unit.

### 1 AUDIO IN (CD) connector

This makes an analog audio connection.

The        sections in the connection diagram are also available for connections. To connect devices to these connectors, you must set up input connectors. For details, see "Input Assign" ([page 112](#)).



## Connecting an FM/AM antenna

- Connect the FM antenna supplied with the unit to enjoy listening to radio broadcasts.
- After connecting the antenna and receiving a broadcast signal (see [page 36](#) "Listening to FM/AM broadcasts"), fix the antenna with tape in a position where the noise level becomes minimal.

### AM loop antenna assembly

**1** Put the stand section through the bottom of the loop antenna from the rear and bend it forward.

**2** Insert the projecting part into the square hole in the stand.

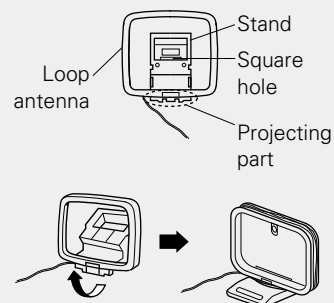

### Using the AM loop antenna

#### Suspending on a wall

Suspend directly on a wall without assembling.

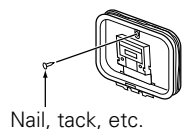

Nail, tack, etc.

#### Standing alone

Use the procedure shown above to assemble.

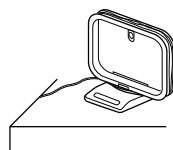

### NOTE

- Do not connect two FM antennas simultaneously.
- Even if an external AM antenna is used, do not disconnect the AM loop antenna.
- Make sure the AM loop antenna lead terminals do not touch metal parts of the panel.
- If the signal has noise interference, connect the ground terminal (GND) to reduce noise.
- If you are unable to receive a good broadcast signal, we recommend installing an outdoor antenna. For details, inquire at the retail store where you purchased the unit.

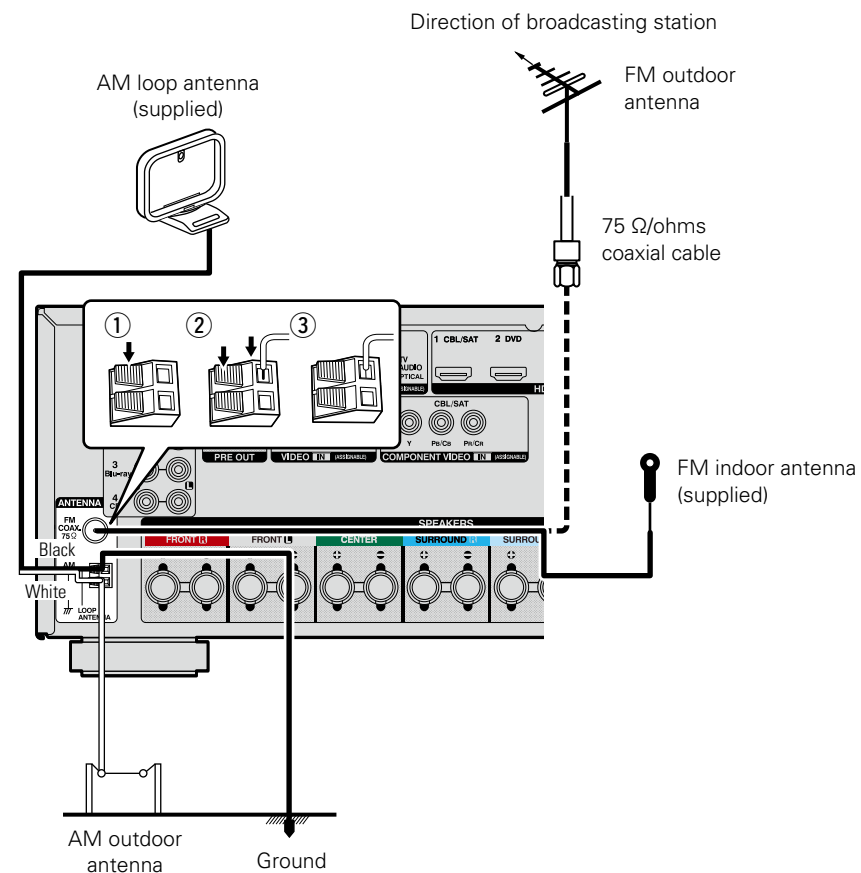

## Connecting to a home network (LAN)

You can connect this unit to your home network (LAN) to perform various types of playbacks and operations as follows. Make network connections for this unit by carefully reading information on this page.

- Playback of network audio such as Internet Radio and from your media server(s)
- Playback of music content from online streaming services
- Using the Apple AirPlay function
- Operation on this unit via the network

In addition, if updated firmware becomes available for this unit, the updated information is delivered from us to this unit over the internet via your home network. You can then download and install the latest firmware.

For more information, on the menu, select "Update" ([page 127](#)).

Network settings are necessary. See "Network" on the menu ([page 119](#)) for more information on network setting.

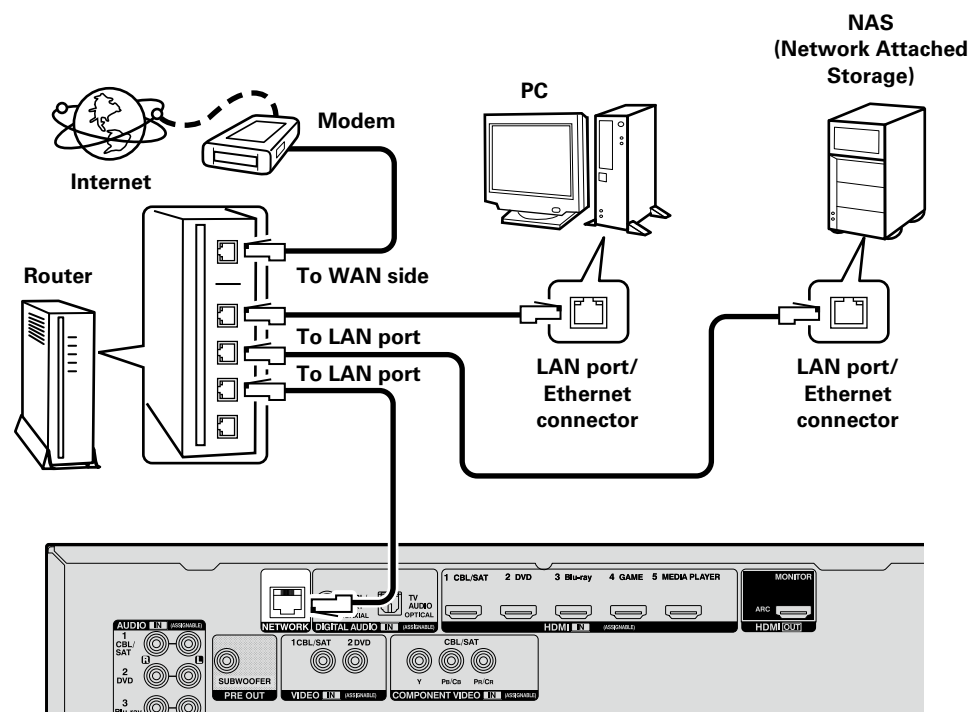

**For connections to the Internet, contact an ISP (Internet Service Provider) or a computer shop.**

## Required system

### Broadband internet connection

### Modem

Device that connects to your broadband internet provider, and is very often supplied with the service. A type that is integrated with a router is also often available.

### Router

When using this unit, we recommend you use a router equipped with the following functions:

- Built-in DHCP server  
This function automatically assigns IP addresses on the LAN.
- Built-in 100BASE-TX switch  
When connecting multiple devices, we recommend a switching hub with a speed of 100 Mbps or greater.

### Ethernet cable (CAT-5 or greater recommended)

- Use only a shielded STP or ScTP LAN cable which is easily available at electronics stores.
- The normal shielded-type Ethernet cable is recommended. If a flat-type cable or unshielded-type cable is used, other devices could be affected by noise.



- If you have an Internet provider contract for a line on which network settings are made manually, make the settings at "Network" ([page 119](#)).
- With this unit, it is possible to use the DHCP and Auto IP functions to make the network settings automatically.
- When using this unit with the broadband router's DHCP function enabled, this unit automatically performs the IP address setting and other settings.  
When using this unit connected to a network with no DHCP function, make the settings for the IP address, etc., at "Network" ([page 119](#)).
- When setting manually, check the settings with the network administrator or internet service provider.

### NOTE

- A contract with an internet service provider (ISP) is usually required to connect to the Internet. No additional contract is needed if you already have a broadband connection to the Internet.
- The types of routers that can be used depend on the ISP. Contact your ISP or a computer shop for details.
- Denon assumes no responsibility whatsoever for any communication errors or troubles resulting from the customer's network environment or connected devices.
- This unit is not compatible with PPPoE. A PPPoE-compatible router is required if you have a contract for a type of line set by PPPoE.
- Do not connect an NETWORK connector directly to the LAN port/ Ethernet connector on your computer.
- To listen to audio streaming, use a router that supports audio streaming.

## Connecting the power cord

After completing all the connections, insert the power plug into the power outlet.

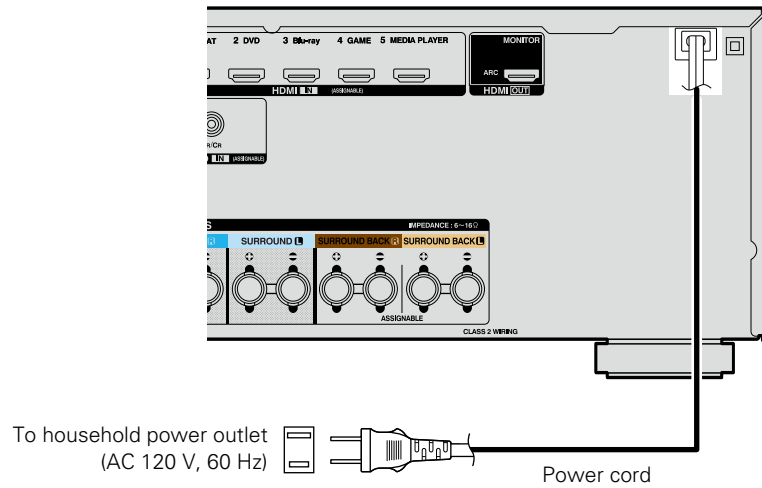

### NOTE

- Do not plug in the power cord until all connections have been completed. However, when the "Setup Assistant" is running, follow the instructions in the "Setup Assistant" (page 7) screen for making connections. (During "Setup Assistant" operation, the input/output connectors do not conduct current.)
- Do not bundle power cords together with connection cables. Doing so can result in humming or noise.

# Setup

Here, we explain “Audyssey® Setup”, which allows you to automatically make the optimal settings for your speakers, and “Network”, which allows you to connect this unit to a home network (LAN). This unit lets you play via your home network (LAN) music files stored on a computer and music content such as that from Internet Radio.

❑ **Speaker connection** (🔗 page 79)

❑ **Set up speakers (Audyssey® Setup)** (🔗 page 21)

❑ **Making the network settings (Network)**  
(🔗 page 27)

**Playback (Basic operation)** (🔗 page 28)

**Selecting a listening mode (Sound Mode)**  
(🔗 page 71)

**Playback (Advanced operation)** (🔗 page 88)



## Set up speakers (Audyssey® Setup)



The acoustic characteristics of the connected speakers and listening room are measured and the optimum settings are made automatically. This is called “Audyssey® Setup”.

To perform measurement, place the Setup and measurement microphone in multiple locations all around the listening area. For best results, we recommend you measure in six positions, as shown in the illustration (up to six positions).

- When performing Audyssey® Setup, Audyssey MultEQ®/Audyssey Dynamic EQ®/Audyssey Dynamic Volume® functions become active (🔗 page 104, 105).
- To set up the speakers manually, use “Speakers” (🔗 page 115) on the menu.

### NOTE

- Make the room as quiet as possible. Background noise can disrupt the room measurements. Close windows and turn off the power on electronic devices (TVs, radios, air conditioners, fluorescent lights, etc.). The measurements could be affected by the sounds emitted by such devices.
- During the measurement process, place cell phones outside the listening room. Cell phone signals could disrupt the measurements.
- Do not unplug the Setup and measurement microphone from the main unit until Audyssey® Setup is completed.
- Do not stand between the speakers and Setup and measurement microphone or allow obstacles in the path while the measurements are being made. This will cause inaccurate readings.
- During the measurement process, audible test tones will come from the speakers and subwoofer(s), but this is part of normal operation. If there is background noise in the room, these test signals will increase in volume.
- Operating **VOLUME ▲▼** on the remote control unit or **MASTER VOLUME** on the main unit during the measurements will cancel the measurements.
- Measurement cannot be performed when headphones are connected. Unplug the headphones before performing Audyssey® Setup.



### About Setup and measurement microphone placement

- Measurements are performed by placing the Setup and measurement microphone successively at multiple positions throughout the entire listening area, as shown in [Example ①]. For best results, we recommend you measure in six positions, as shown in the illustration (up to six positions).
- Even if the listening environment is small as shown in [Example ②], measuring at multiple points throughout the listening environment results in more effective correction.

[Example ①]

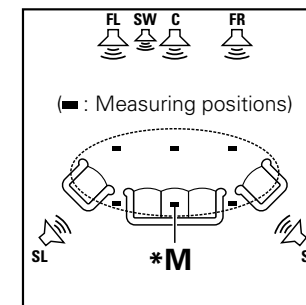

[Example ②]

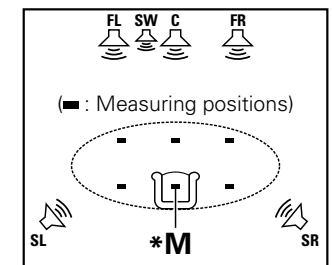

**FL** Front speaker (L)  
**FR** Front speaker (R)  
**C** Center speaker

**SW** Subwoofer  
**SL** Surround speaker (L)  
**SR** Surround speaker (R)

### About the main listening position (\*M)

The main listening position is the position where listeners would normally sit or where one would normally sit alone within the listening environment. Before starting Audyssey® Setup, place the Setup and measurement microphone in the main listening position. Audyssey MultEQ® uses the measurements from this position to calculate speaker distance, level, polarity, and the optimum crossover value for the subwoofer.

## 1 Prepare the included Setup and measurement microphone

Mount the Setup and measurement microphone on a tripod or stand and place it in the main listening position.

When placing the Setup and measurement microphone, adjust the height of the sound receptor to the level of the listener's ear.

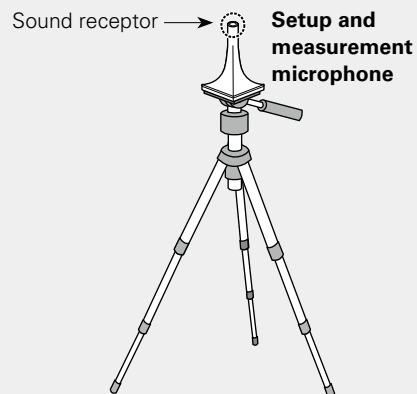

If you do not have a tripod or stand, set up the microphone on, for example, a seat without a back.

### NOTE

- Do not hold the Setup and measurement microphone in your hand during measurements.
- Avoid placing the Setup and measurement microphone close to a seat back or wall as sound reflections may give inaccurate results.

## 2 Set up the subwoofer

If using a subwoofer capable of the following adjustments, set up the subwoofer as shown below.

For details, see your subwoofer's manual.

- When using a subwoofer with a direct mode**  
Set the direct mode to "On" and disable the volume adjustment and crossover frequency setting.
- When using a subwoofer without a direct mode**  
Make the following settings:
  - **Volume** : "12 o'clock position"
  - **Crossover frequency** : "Maximum/Highest Frequency"
  - **Low pass filter** : "Off"
  - **Standby mode** : "Off"

## 3 Set up the zone mode

Press **MAIN** to switch the zone mode.  
**MAIN** lights.

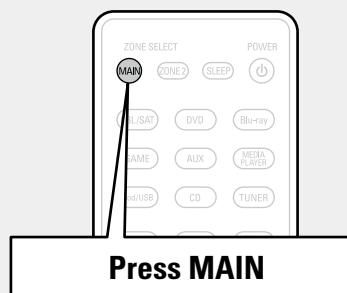

## Preparation

### 4 Connect the Setup and measurement microphone to the SETUP MIC jack of this unit.

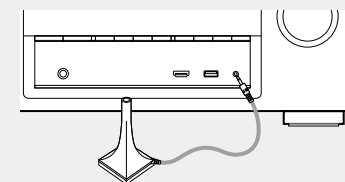

When the Setup and measurement microphone is connected, the following screen is displayed.

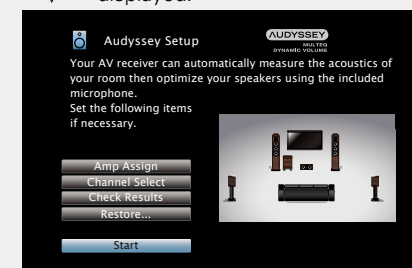

- Here, we explain setup using the example of 5.1-channel speaker playback.  
For settings other than 5.1-channel speaker playback, select "Amp Assign" and perform step 3 to 6 of "Set up "Amp Assign"" ([page 86](#)).
- If unused channels are set with "Channel Select", measuring time can be shortened. For setting, perform steps 7 to 11 of "Set up "Channel Select"" ([page 87](#)).

## Preparation (Continued)

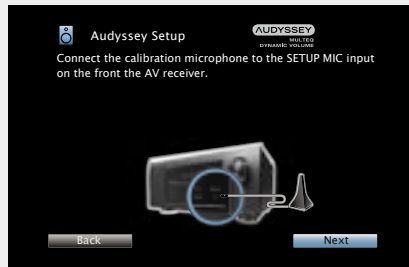
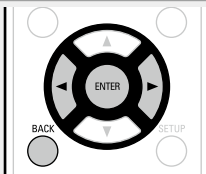
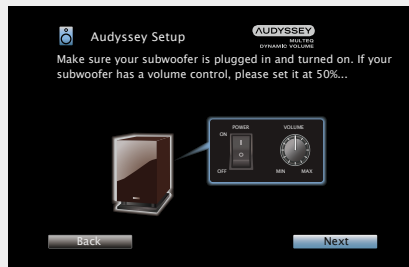
**5** Select “Start” and then press **ENTER**.**6** Select “Next” and then press **ENTER**.  
The subwoofer volume setting screen is displayed.

## Detection &amp; Measurement (Main)

This step automatically checks the speaker configuration and speaker size, and calculates the channel level, distance, and crossover frequency.

It also corrects distortion in the listening area.

**7** Select “Begin Test” and then press **ENTER**.

When measuring begins, a test tone is output from each speaker.

- Measurement requires several minutes.

**8** The detected speakers are displayed.

- The illustration below shows an example of when the front speakers, center speaker, subwoofer and surround speakers have been detected.

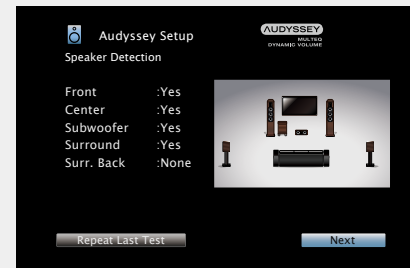
**NOTE**

If a connected speaker is not displayed, the speaker may not be connected correctly. Check the speaker connection.

**9** Select “Next” and then press **ENTER**.**NOTE**

If “Caution!” is displayed on TV screen:

Go to “Error messages” ([page 26](#)). Check any related items, and perform the necessary procedures.

If the problem is resolved, return and restart “Audyssey® Setup”.

**Going back to the previous screen**

Select “Back” and then press **ENTER**.

**When measuring has stopped**

- ① Press **BACK** to display the popup screen.
- ② Press **◀** to select “Yes”, and then press **ENTER**.

**Setting up the speakers again**

Repeat the operation from step 4.

## Measurement (2nd – 6th)

- In this step, you will perform measurements at multiple positions (one to five additional positions) other than the main listening position.
- Just one listening position can be measured if you so choose, but measuring multiple positions increases the accuracy of the correction of acoustic distortion within the listening area.

### 10 Move the Setup and measurement microphone to position 2, select “Continue”, and then press ENTER.

The measurement of the second position starts. Measurements can be made in up to six positions.

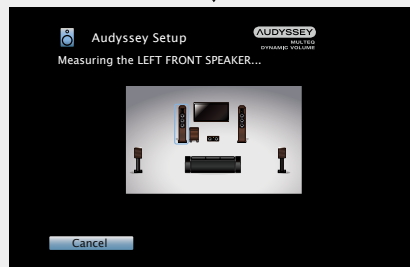
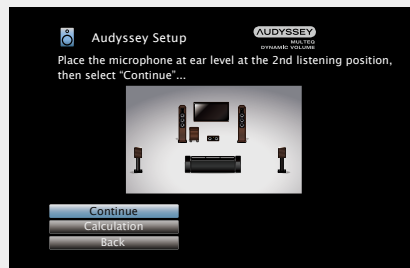
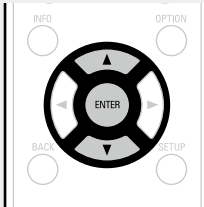

- To skip measuring the second and subsequent listening position, use  $\nabla$  to select “Calculation” and press **ENTER** to proceed to step 13.
- To measure the second position again, use  $\nabla$  to select “Repeat Last Test” and press **ENTER**.

## Calculation

### 11 Repeat step 10, measuring positions 3 to 6.

When measurement of position 6 is completed, a “Measurements finished.” message is displayed.

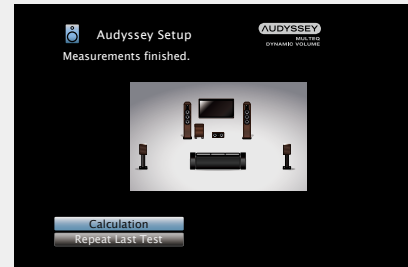

### 12 Select “Calculation” and then press ENTER.

Measuring results are analyzed, and the frequency response of each speaker in the listening room is determined.

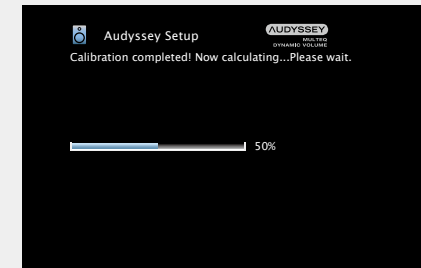

- Analysis takes several minutes to complete. The more speakers and measurement positions that there are, the more time it takes to perform the analysis.

## Check

- 13** Use  $\Delta$ / $\nabla$  to select the item you want to check, and then press **ENTER**.

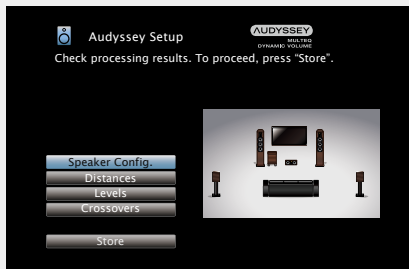
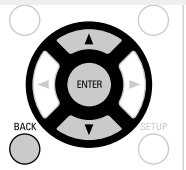

- Subwoofers may measure a greater reported distance than the actual distance due to added electrical delay common in subwoofers.
- If you want to check another item, press **BACK**.

**NOTE**

- If the result differs from the actual connection status, or if "Caution!" is displayed, see "Error messages" ([page 26](#)). Then carry out Audyssey® Setup again.
- If you change speaker positions or orientation, perform Audyssey® Setup again to find the optimal equalizer settings.

## Store

- 14** Select "Store" and then press **ENTER**.  
Save the measurement results.

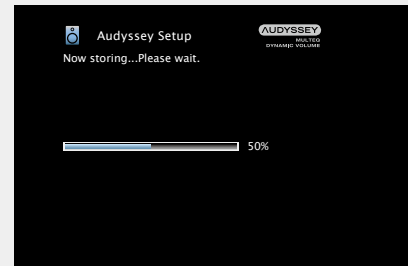
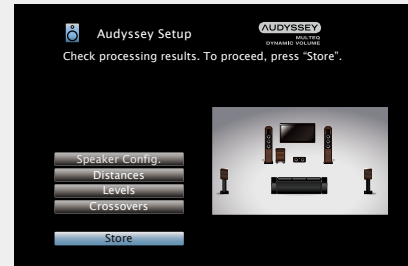

- Saving the results requires about 20 seconds.
- During saving of measurements results, "Now storing...Please wait." is displayed. When saving is completed, "Storing complete. Audyssey® Setup is now finished. Please unplug microphone." is displayed.

**NOTE**

During saving of measurement results, be sure not to turn off the power.

## Finish

- 15** Unplug the Setup and measurement microphone from the unit's SETUP MIC jack.

- 16** Set Audyssey Dynamic Volume®.

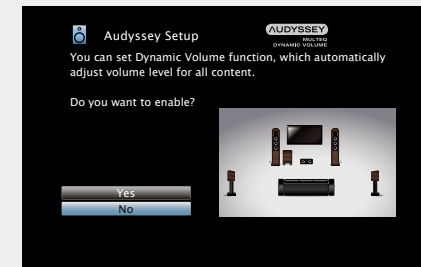

- This feature adjusts the output volume to the optimal level while constantly monitoring the level of the audio input to the unit. Optimal volume control is performed automatically without any loss in the dynamism and clarity of the sound when, for example, the volume suddenly increases for commercials shown during television programs.

 **When turning Dynamic Volume on**

- Press  $\Delta$  to select "Yes", and then press **ENTER**.

The unit automatically enters "Medium" ([page 105](#)) mode.

 **When turning Dynamic Volume off**

- Press  $\nabla$  to select "No", and then press **ENTER**.

**NOTE**

After performing Audyssey® Setup, do not change the speaker connections or subwoofer volume. In event of a change, perform Audyssey® Setup again.



## Error messages

### NOTE

- An error message is displayed if Audyssey® Setup could not be completed due to speaker placement, the measurement environment, etc. If an error message is displayed, check the relevant items and perform the necessary measures. Then perform Audyssey® Setup again.
- If the result still differs from the actual connection status after re-measurement or the error message still appears, it is possible that the speakers are not connected properly. Turn this unit off, check the speaker connections and repeat the measurement process from the beginning.
- Be sure to turn off the power before checking speaker connections.

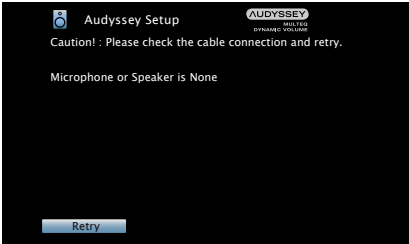
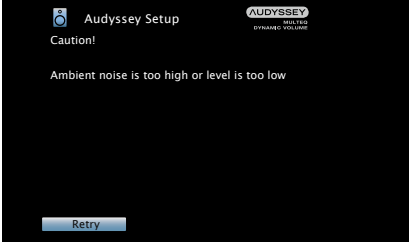
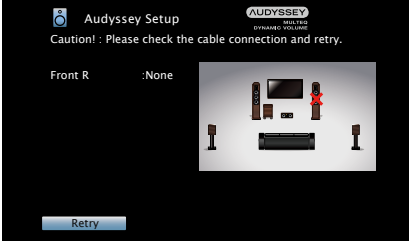
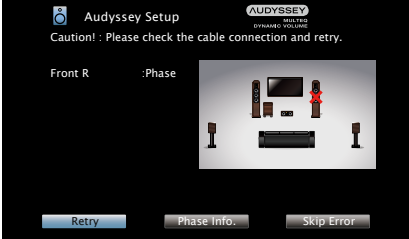
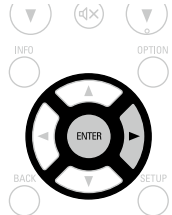
Examples	Error details	Measures
 <p>Audyssey Setup Caution! : Please check the cable connection and retry. Microphone or Speaker is None Retry</p>	<ul style="list-style-type: none"> <li>• The connected Setup and measurement microphone is broken, or a device other than the supplied Setup and measurement microphone is connected.</li> <li>• Not all speakers could be detected.</li> </ul>	<ul style="list-style-type: none"> <li>• Connect the included Setup and measurement microphone to the SETUP MIC jack of this unit.</li> <li>• Check the speaker connections.</li> </ul>
 <p>Audyssey Setup Caution! Ambient noise is too high or level is too low Retry</p>	<ul style="list-style-type: none"> <li>• There is too much noise in the room for accurate measurements to be made.</li> <li>• Speaker or subwoofer sound is too low for accurate measurements to be made.</li> </ul>	<ul style="list-style-type: none"> <li>• Either turn off any device generating noise or move it away.</li> <li>• Perform again when the surroundings are quieter.</li> <li>• Check the speaker installation and the direction in which the speakers are facing.</li> <li>• Adjust the subwoofer's volume.</li> </ul>
 <p>Audyssey Setup Caution! : Please check the cable connection and retry. Front R :None Retry</p>	<ul style="list-style-type: none"> <li>• The displayed speaker could not be detected. (The screen on the left indicates that the front right speaker cannot be detected.)</li> </ul>	<ul style="list-style-type: none"> <li>• Check the connections of the displayed speaker.</li> </ul>
 <p>Audyssey Setup Caution! : Please check the cable connection and retry. Front R :Phase Retry Phase Info. Skip Error</p>	<ul style="list-style-type: none"> <li>• The displayed speaker is connected with the polarity reversed. (The screen on the left indicates that the polarity phases of the front right speakers are reversed.)</li> </ul>	<ul style="list-style-type: none"> <li>• Check the polarity of the displayed speaker.</li> <li>• For some speakers, this error message may be displayed even if the speaker is properly connected. If you are sure the connection is correct, use <math>\blacktriangleright</math> to select "Skip Error", then press <b>ENTER</b>.</li> </ul> 

## Check Results

This function enables you to check the measurement results and equalizer characteristics after Audyssey® Setup.

- 1** Press **SETUP** to display the menu on the TV screen.
- 2** Use  $\Delta$  to select “Speakers” – “Audyssey® Setup” and then press **ENTER** or  $\triangleright$ .
- 3** Use  $\nabla$  to select “Check Results” and then press **ENTER**.

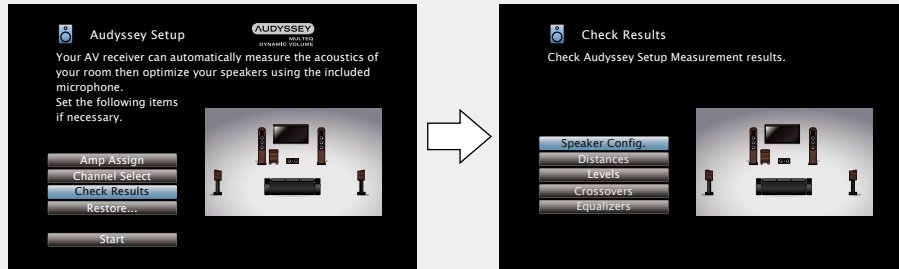

- 4** Use  $\Delta$ / $\nabla$  to select the item you want to check, then press **ENTER**.  
Measurement results for each speaker are displayed.

<b>Speaker Config.</b>	Check the speaker configuration.
<b>Distances</b>	Check the speaker distance.
<b>Levels</b>	Check the speaker channel level.
<b>Crossovers</b>	Check the speaker crossover frequency.
<b>Equalizers</b>	Check the equalizer.

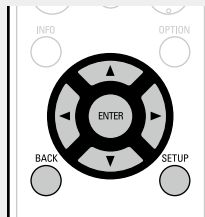

- If “Equalizers” is selected, press  $\Delta$ / $\nabla$  to select equalizing curve (“Audyssey” or “Audyssey Flat”) to be checked.  
Use  $\Delta$ / $\nabla$  to switch the display between the different speakers.

- 5** Press  $\triangleleft$  or **BACK**.  
The confirmation screen reappears. Repeat step 2.

## Retrieving Audyssey® Setup settings

If you set “Restore...” to “Restore”, you can return to Audyssey® Setup measurement result (value calculated at the start by MultEQ®) even when you have changed each setting manually.



## Making the network settings (Network)



This unit can be connected to a home network (LAN) to listen to Internet Radio or play back music files and still image (JPEG) files stored on a computer.

- 1** Connect the Ethernet cable (👉 [page 19](#) “Connecting to a home network (LAN)”).
- 2** Turn on this unit (👉 [page 28](#)).  
This unit performs automatic network setup due to the DHCP function.  
When connecting to a network that has no DHCP function, perform the setting in “Settings” (👉 [page 121](#)).

# Playback (Basic operation)

## Setup (👉 page 21)

- ❑ Turning the power on (👉 page 28)
- ❑ Selecting the input source (👉 page 28)
- ❑ Adjusting the master volume (👉 page 29)
- ❑ Turning off the sound temporarily (👉 page 29)

## ❑ Playing a Blu-ray Disc player/DVD player (👉 page 29)

- ❑ Playing a CD player (👉 page 29)
- ❑ Playing an iPod (👉 page 30)
- ❑ Playing a USB memory device (👉 page 33)
- ❑ Listening to FM/AM broadcasts (👉 page 36)

- ❑ Listening to Internet Radio (👉 page 45)
- ❑ Playing back files stored on a PC and NAS (👉 page 48)
- ❑ Using online services (👉 page 52)
- ❑ Convenient functions (👉 page 63)
- ❑ AirPlay function (👉 page 69)

## Selecting a listening mode (Sound Mode) (👉 page 71)

## Playback (Advanced operation) (👉 page 88)

## Important information

Before starting playback, make the connections between the different devices and the settings on the unit.

### NOTE

Also refer to the operating instructions of the connected devices when playing them.

## Turning the power on

Press **POWER**  to turn on power to the unit.

The power indicator flashes green and the power turns on.



You can also switch the power to standby by pressing  on the main unit.

## ❑ When power is switched to standby

Press **POWER** .

### [Power indicator status in standby mode]

Normal standby : Off

- When "HDMI Pass Through" or "HDMI Control" (👉 page 108) is set to "On" : Red
- When "IP Control" (👉 page 120) is set to "Always On" : Red

## Selecting the input source

Press the input source select button (CBL/SAT, DVD, Blu-ray, GAME, AUX, MEDIA PLAYER, iPod/USB, CD, TUNER, NETWORK, TV AUDIO or INTERNET RADIO) to be played back.



The desired input source can be selected directly.



You can also use the following operation to select an input source.

## ❑ Select the input source using the main unit

Press **SOURCE SELECT**  .

- Pressing **SOURCE SELECT**   switches the input source, as shown below.

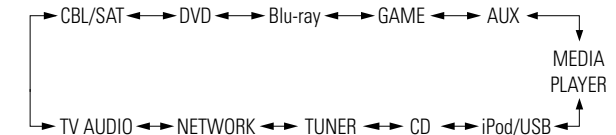

## Adjusting the master volume

Use **VOLUME ▲▼** to adjust the volume.

- The volume display method varies depending on the "Scale" setting (page 104).



☐ When the "Scale" setting (page 104) is "0 – 98"

[Adjustable range] 0.0 0.5 – 98.0

☐ When the "Scale" setting (page 104) is "-79.5dB – 18.0dB"

[Adjustable range] ---- -79.5dB – 18.0dB

- The variable range differs according to the input signal and channel level setting.



You can also adjust the master volume by turning **MASTER VOLUME** on the main unit.

## Turning off the sound temporarily

Press **MUTE ◀X**.

- "MUTE" indicator on the display flashes.
- ◀X appears on the TV screen.



- The sound is reduced to the level set at "Mute Level" (page 104).
- To cancel, press **MUTE ◀X** again. Muting can also be cancelled by adjusting the master volume.

## Playing a Blu-ray Disc player/DVD player

The following describes the procedure for playing Blu-ray Disc player/DVD player.

### 1 Prepare for playback.

- Turn on the power of the TV, subwoofer and player.
- Change the TV input to the input of this unit.
- Load the disc in the player.

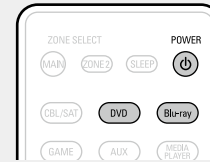

### 2 Press **POWER** to turn on power to the unit.

### 3 Press **DVD** or **Blu-ray** to switch an input source for a player used for playback.

### 4 Play the Blu-ray Disc player or DVD player.

- Make the necessary settings on the player (language setting, subtitles setting, etc.) beforehand.

## Playing a CD player

The following describes the procedure for playing CD player.

### 1 Prepare for playback.

- Turn on the power of the subwoofer and player.
- Load the disc in the player.

### 2 Press **POWER** to turn on power to the unit.

### 3 Press **CD** to switch the input source to "CD".

### 4 Play the CD player.



## Playing an iPod

You can use the USB cable provided with the iPod to connect the iPod with the unit's USB port and enjoy music stored on the iPod.

For information on the iPod models that can be played back with this unit, see "Connecting an iPod or USB memory device to the USB port" ([page 16](#)).

## Listening to music on an iPod

The iPod display modes include "From iPod" and "On-Screen". By default, "From iPod", where you directly operate the iPod itself while looking at the iPod screen, is set.

To change to "On-Screen", where you perform operations while having the iPod information displayed on the TV screen, see "Setting operation mode (iPod Browse Mode)" ([page 31](#)).

**1** Using the USB cable provided with the iPod, connect the iPod to the USB port ([page 16](#)).

**2** Press **POWER**  to turn on power to the unit.

**3** Press **iPod/USB** to switch the input source to "iPod/USB". "Browse From iPod" is displayed on the display of this unit.

- Nothing is displayed on the TV screen.

**4** Operate iPod itself directly while seeing the iPod screen to play back music.



- Streaming music stored in iPhone, iPod touch, or iPad directly to the unit ([page 69](#))
- Playing iTunes music with this unit ([page 69](#))

## Operations available through the OPTION button

Press the **OPTION** button to display a menu of functions that can be used on the TV screen. Select the function you want to use from this menu. You can easily find and use the desired function.

Performing repeat playback (Repeat) ([page 32](#))

Performing random playback (Random) ([page 32](#))

Setting operation mode (iPod Browse Mode) ([page 31](#))

Displaying your desired video on the monitor during audio playback (Video Select) ([page 67](#))

Adjusting the picture quality for your viewing environment (Picture Mode) ([page 67](#))

All Zone Stereo function ([page 68](#))

**❑ Setting operation mode (iPod Browse Mode)**

In this mode, various lists and screens during playback on the iPod are displayed on the TV screen.  
This section describes the steps up to playing back tracks on the iPod in "On-Screen".

**1 Press iPod/USB to switch the input source to "iPod/USB".**

**2 Press OPTION.**  
The option menu screen is displayed.

**3 Select "iPod Browse Mode", then press ENTER.**  
The "iPod Browse Mode" screen is displayed.

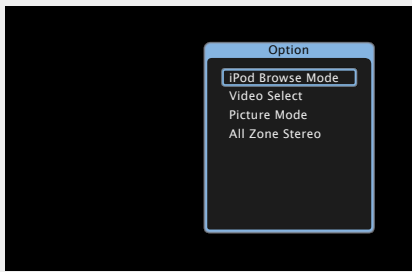

**4 Use < and > to select "On-Screen", then press ENTER.**  
The iPod screen is displayed.

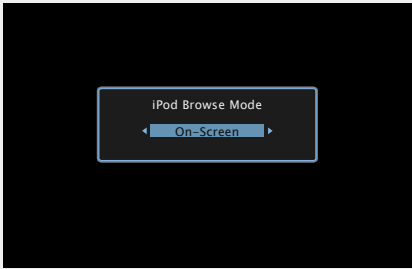

- English letters, numbers and certain symbols are displayed. Incompatible characters are displayed as "." (period).
- Operations available for "On-Screen" and "From iPod" are listed below.

Display mode		From iPod	On-Screen
Playable files	Music file	✓	✓
	Video file	*	
Active buttons	Remote control unit (This unit)	✓	✓
	iPod	✓	

\* Only the sound is played.

**5 Use Δ and ∇ to select the item, then press ENTER or ▷ to select the file to be played.**

**6 Press ENTER, ▷ or ▶/II.**  
Playback starts.

**❑ Adjusting the sound quality (Restorer)**

Make this setting at "Restorer" (page 103) in the menu.  
You can use the Restorer function to improve the fidelity of compressed audio sources such as MP3 files. The Restorer has selectable levels of restoration. The default setting is "Low".

**❑ Changing the screen display duration**

Make this setting at "Now Playing" (page 110) in the menu. The default setting is "Always On".  
When "Auto Off" is set, the on-screen display is turned off 30 seconds after an operation.  
Press Δ∇◁▷ while the display is off to return to the original screen.

**❑ Switching the screen display**

Press **STATUS** on this unit during playback with "iPod Browse Mode" set to "On-Screen".  
The display switches between track title, artist name, and album title etc. each time the button is pressed.

**NOTE**

- Depending on the type of iPod and the software version, some functions may not operate.
- Note that Denon will accept no responsibility whatsoever for any problems arising with the data on an iPod when using this unit in conjunction with the iPod.

**Performing repeat playback (Repeat)**

**1** Press **OPTION** with “iPod Browse Mode” set to “On-Screen”.  
The option menu screen is displayed.

**2** Use  $\Delta$ / $\nabla$  to select “Repeat”, then press **ENTER**.

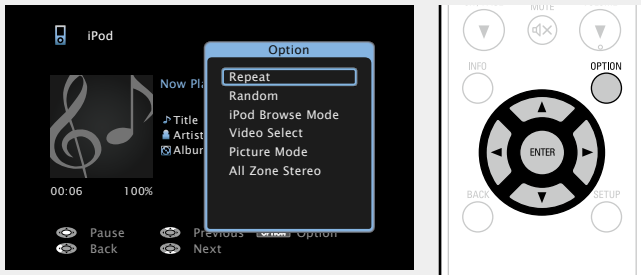

**3** Use  $\triangleleft$ / $\triangleright$  to select repeat playback mode.

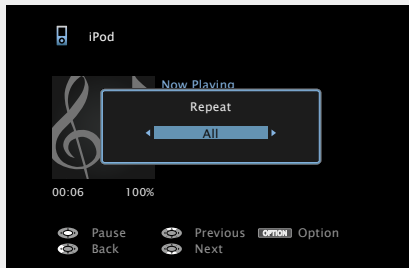

• Each time  $\triangleleft$ / $\triangleright$  is pressed, the setting is changed as shown below.



- Off** Repeat playback mode is canceled.
- One** A file being played is played repeatedly.
- All** All files in the folder currently being played are played repeatedly.

**4** Press **ENTER**.  
The display returns to the playback screen.

**Performing random playback (Random)**

**1** Press **OPTION** with “iPod Browse Mode” set to “On-Screen”.  
The option menu screen is displayed.

**2** Use  $\Delta$ / $\nabla$  to select “Random”, then press **ENTER**.

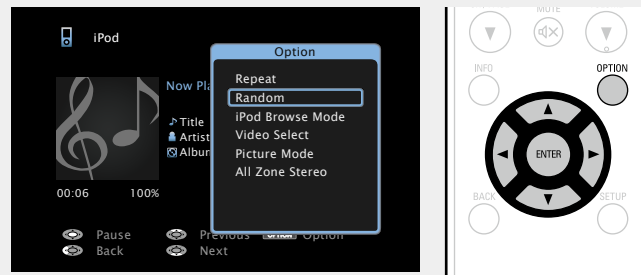

**3** Use  $\triangleleft$ / $\triangleright$  to select random playback mode.

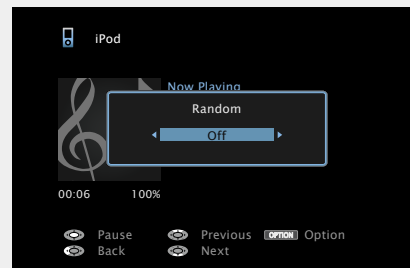

• Each time  $\triangleleft$ / $\triangleright$  is pressed, the setting is changed as shown below.



- Off** Disable random playback.
- On** Randomly play back all tracks in the current playback folder.

**4** Press **ENTER**.  
The display returns to the playback screen.



During random playback, each time playback of a track is completed, another track is randomly selected for playback from tracks in the folder. Therefore, it's possible that you may hear a track played back more than once during random playback.

**iPod operation buttons**

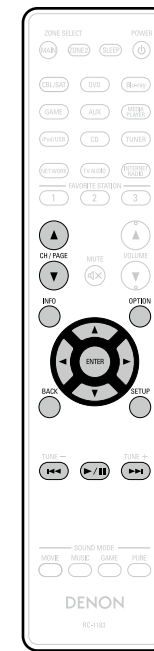

Operation buttons	Function
<b>CH/PAGE</b> $\Delta$ / $\nabla$	Page search
<b>INFO</b>	Display of information such as the source name, volume, and sound mode name
<b>OPTION</b>	Repeat playback / Random playback / iPod Browse Mode switching / Video Select / Picture Mode / All Zone Stereo
$\Delta$ / $\nabla$ / $\triangleleft$ / $\triangleright$	Cursor operation / Next/Previous ( $\Delta$ / $\nabla$ ) / Fast-forward/Fast-reverse (Press and hold, $\Delta$ / $\nabla$ )
<b>ENTER</b> (Press and release)	Enter / Playback / Pause
<b>ENTER</b> (Press and hold)	Stop
<b>BACK</b>	Return
<b>SETUP</b>	Setup menu
$\lll$ $\ggg$ (Press and release)	Next/Previous
$\lll$ $\ggg$ (Press and hold)	Fast-forward/Fast-reverse
$\blacktriangleright$ / <b>II</b>	Playback / Pause

# Playing a USB memory device

Playing back music or viewing still picture (JPEG) files stored on a USB memory device.

## Important information

- Only USB memory devices conforming to mass storage class and MTP (Media Transfer Protocol) standards can be played on this unit.
- This unit is compatible with USB memory devices in “FAT16” or “FAT32” format.
- This unit is compatible with MP3 files conforming to “MPEG-1 Audio Layer-3” standards.
- File types that this unit can play back and specifications are shown below.

### [Supported file types]

Supported file types	USB memory devices *1
<b>WMA</b> (Windows Media Audio)	✓*2
<b>MP3</b> (MPEG-1 Audio Layer-3)	✓
<b>WAV</b>	✓
<b>MPEG-4 AAC</b>	✓*3
<b>FLAC</b> (Free Lossless Audio Codec)	✓
<b>JPEG</b>	✓
<b>ALAC</b> (Apple Lossless Audio Codec)	✓

\*1 USB memory device

- This unit is compatible with MP3 ID3-Tag (Ver. 2) standard.
- This unit can show the artwork that was embedded by using MP3 ID3-Tag Ver. 2.3 or 2.4.
- This unit is compatible with WMA META tags.
- If the image size (pixels) of an album artwork exceeds 500 × 500 (WMA/MP3/WAV/FLAC) or 349 × 349 (MPEG-4 AAC), then music may not be played back properly.
- WAV format Quantization bit length: 16 or 24 bits.
- FLAC format Quantization bit length: 16 or 24 bits.

\*2 Copyright-protected files can be played on certain portable players compatible with MTP.

\*3 Only files that are not protected by copyright can be played on this unit.

Content downloaded from pay sites on the Internet are copyright protected. Also, files encoded in WMA format when ripped from a CD, etc. on a computer may be copyright protected, depending on the computer’s settings.

### NOTE

File types that this unit does not support are not displayed.

### [Compatible formats]

	Sampling frequency	Bit rate	Extension
<b>WMA</b> (Windows Media Audio)	32/44.1/48 kHz	48 – 192 kbps	.wma
<b>MP3</b> (MPEG-1 Audio Layer-3)	32/44.1/48 kHz	32 – 320 kbps	.mp3
<b>WAV</b>	32/44.1/48/88.2/96/ 176.4/192 kHz	–	.wav
<b>MPEG-4 AAC</b>	32/44.1/48 kHz	16 – 320 kbps	.aac/ .m4a/ .mp4
<b>FLAC</b> (Free Lossless Audio Codec)	32/44.1/48/88.2/96/ 176.4/192 kHz	–	.flac
<b>ALAC</b> (Apple Lossless Audio Codec)*	32/44.1/48/88.2/96 kHz	–	.m4a

\* Copyright [2012] [D&M Holdings. Inc.]

Licensed under the Apache License, Version 2.0 (the “License”); you may not use this file except in compliance with the License. You may obtain a copy of the License at <http://www.apache.org/licenses/LICENSE-2.0>

### □ Maximum Number of Playable Files and Folder

The limits on the number of folders and files that can be displayed by this unit are as follows.

Item	Media	USB memory devices
Memory capacity		FAT16 : 2 GB, FAT32 : 2 TB
Number of folder directory levels *1		8 levels
Number of folders		500
Number of files *2		5000

\*1 The limited number includes the root folder.

\*2 The allowable number of files may differ according to the USB memory device capacity and the file size.



## Playing files stored on USB memory devices

**1** Connect the USB memory device to the USB port (page 16).

**2** Press iPod/USB to switch the input source to “iPod/USB”.

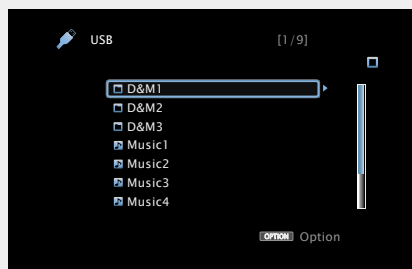

**3** Use  $\Delta$ / $\nabla$  to select the search item or folder, then press ENTER or  $\blacktriangleright$ .

**4** Use  $\Delta$ / $\nabla$  to select the file, then press ENTER,  $\blacktriangleright$  or  $\blacktriangleright/\text{II}$ . Playback starts.

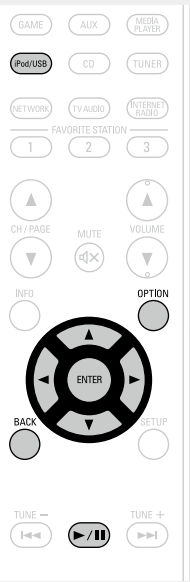

### Adjusting the sound quality (Restorer)

Make this setting at “Restorer” (page 103) in the menu.

You can use the Restorer function to improve the fidelity of compressed audio sources such as MP3 files. The Restorer has selectable levels of restoration. The default setting is “Low”.

### Going back to the previous screen

Press  $\triangleleft$  or **BACK**.

### Changing the screen display duration

Make this setting at “Now Playing” (page 110) in the menu. The default setting is “Always On”.

When “Auto Off” is set, the on-screen display is turned off 30 seconds after an operation.

Press  $\Delta$ / $\nabla$ / $\triangleleft$ / $\triangleright$  while the display is off to return to the original screen.



- When an MP3 music file includes album art data, the album art can be displayed while playing the file.
- If the USB memory device is divided into multiple partitions, only the first partition is played back.

#### NOTE

- Note that Denon will accept no responsibility whatsoever for any problems arising with the data on a USB memory device when using this unit in conjunction with the USB memory device.
- USB memory devices will not work via a USB hub.
- Denon does not guarantee that all USB memory devices will operate or be supplied power. When using a USB portable hard disk that can draw power from an AC adapter, we recommend using the AC adapter.
- It is not possible to connect and use a computer via the USB port of this unit using a USB cable.

## Operations available through the OPTION button

Press the **OPTION** button to display a menu of functions that can be used on the TV screen. Select the function you want to use from this menu. You can easily find and use the desired function.

**Searching content with keywords (Text Search)** (page 63)

**Performing repeat playback (Repeat)** (page 63)

**Performing random playback (Random)** (page 64)

**Playing back still images in sequential order (Slideshow Interval)** (page 66)

**Displaying your desired video on the monitor during audio playback (Video Select)** (page 67)

**Adjusting the picture quality for your viewing environment (Picture Mode)** (page 67)

**All Zone Stereo function** (page 68)



# Listening to FM/AM broadcasts

For antenna connections, see “Connecting an FM/AM antenna” (page 18).

## How to tune in

The modes for receiving FM broadcasts consists of “Auto” mode that automatically searches available broadcast stations and “Manual” mode that lets you tune in using buttons to change the frequency. The default setting is “Auto”. You can also use “Direct Tune” to tune in by entering the frequency directly.

In “Auto” mode, you cannot tune in to radio stations if the reception is not good. If this is the case, then use the “Manual” mode or “Direct Tune” to tune in.

## Listening to FM/AM broadcasts

**1** Press **TUNER** to switch the input source to “TUNER”.

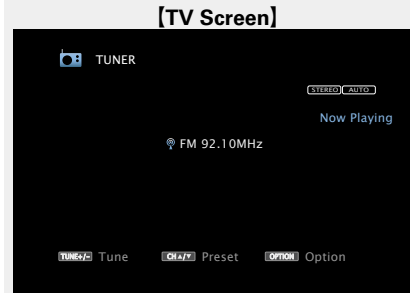

[Display of this unit]

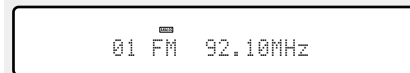

**2** Press **OPTION**.  
The option menu screen is displayed.

**3** Use  $\Delta$ / $\nabla$  to select “FM/AM”, then press **ENTER**.  
The Band screen is displayed.

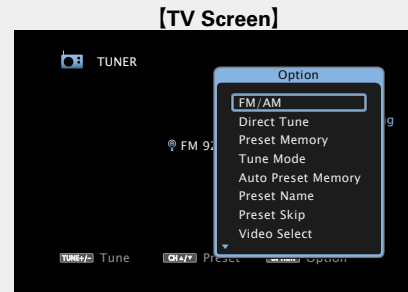

[Display of this unit]

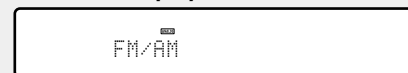

**4** Use  $\triangleleft$ / $\triangleright$  to select “FM” or “AM”, then press **ENTER**.

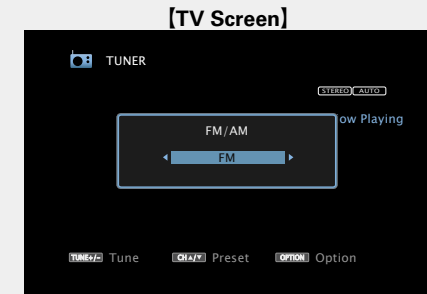

[Display of this unit]

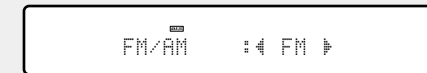

**FM** When listening to an FM broadcast.

**AM** When listening to an AM broadcast.

**5** Press **TUNE +** or **TUNE -** to select the station you want to hear.  
Scanning is performed until it finds an available radio station. When it finds a radio station, it stops the scan automatically and tunes in.



- If the desired station cannot be tuned in with auto tuning, tune it in manually.
- When tuning in stations manually, press and hold **TUNE +** or **TUNE -** to change frequencies continuously.

### ❑ Changing the screen display duration

Make this setting at "Now Playing" ([page 110](#)) in the menu. The default setting is "Always On".

When "Auto Off" is set, the on-screen display is turned off 30 seconds after an operation.

Press  $\Delta \nabla \triangleleft \triangleright$  while the display is off to return to the original screen.

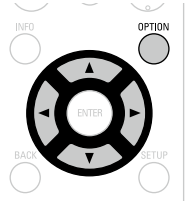

### ❑ Adding to the FAVORITE STATION button

([page 65](#))

### Operations available through the OPTION button

Press the **OPTION** button to display a menu of functions that can be used on the TV screen. Select the function you want to use from this menu. You can easily find and use the desired function.

❑ **Tuning in by entering the radio frequency (Direct Tune)** ([page 38](#))

❑ **Presetting the current broadcast station (Preset Memory)** ([page 39](#))

❑ **Changing the tuning mode (Tune Mode)** ([page 40](#))

❑ **Tuning in to radio stations and presetting them automatically (Auto Preset Memory)** ([page 41](#))

❑ **Specify a name for the preset broadcast station (Preset Name)** ([page 42](#))

❑ **Skipping preset broadcast stations (Preset Skip)** ([page 43](#))

❑ **Displaying your desired video on the monitor during audio playback (Video Select)** ([page 67](#))

❑ **All Zone Stereo function** ([page 68](#))

**Tuning in by entering the radio frequency (Direct Tune)**

You can enter the receiving frequency directly to tune in.

**1** Press **TUNER** to switch the input source to “TUNER”.

**2** Press **OPTION**.  
The option menu screen is displayed.

**3** Use  $\Delta$ / $\nabla$  to select “Direct Tune”, then press **ENTER**.  
The direct tuner screen is displayed and “\_” in the display flashes.

[TV Screen]

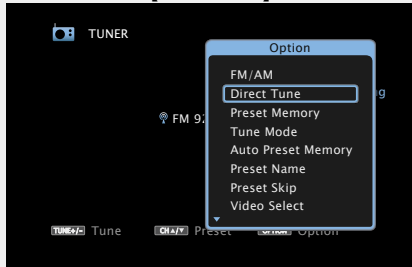

[Display of this unit]

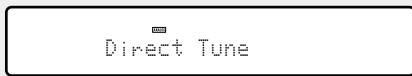

**4** Use  $\Delta$ / $\nabla$  to select a number and press  $\triangleright$ .  
The screen that lets you enter the frequency is displayed.

[TV Screen]

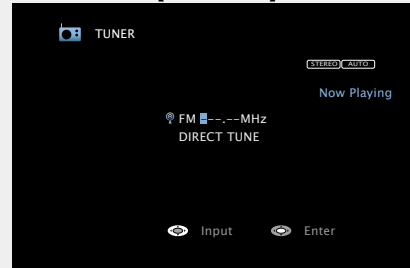

[Display of this unit]

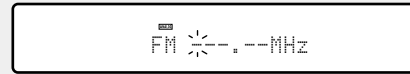
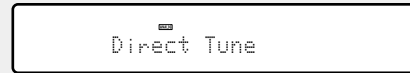

• If  $\triangleleft$  is pressed, the immediately preceding input is cancelled.

**5** Repeat step 4 and enter the frequency of the radio station you want to hear.

**6** When setting is completed, press **ENTER**.  
The preset frequency is tuned in.

### ❑ Presetting the current broadcast station (Preset Memory)

Your favorite broadcast stations can be preset so that you can tune them in easily. Up to 56 stations can be preset.

**1** Tune in the broadcast station you want to preset.

**2** Press **OPTION**.  
The option menu screen is displayed.

**3** Use  $\Delta \nabla$  to select “Preset Memory”, then press **ENTER**.  
The list of already preset channels is displayed.

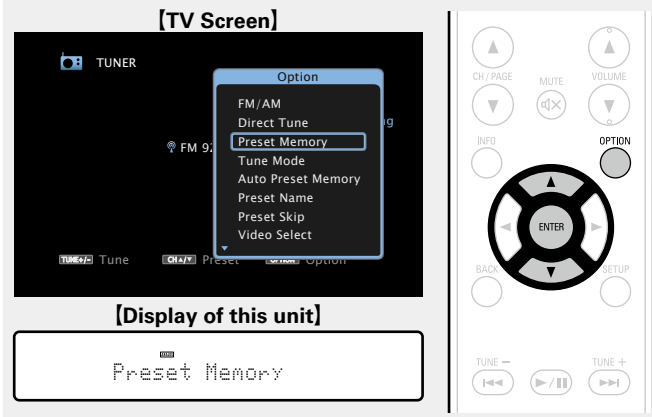

**4** Use  $\Delta \nabla$  to select the channel you want to preset, then press **ENTER**.

The current broadcast station that is preset.

- To preset other stations, repeat steps 1 to 4.

[TV Screen]

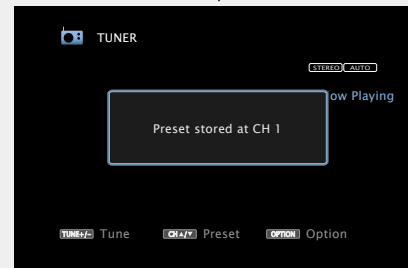
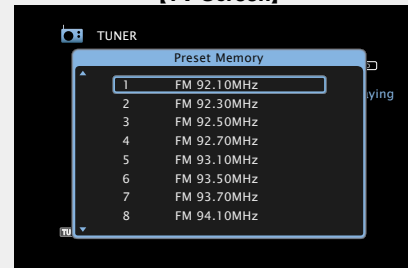

[Display of this unit]

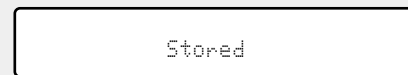
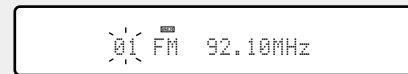

The channel numbers of broadcast stations set as “Preset Skip” (see page 43) are grayed out, but these stations can be preset.

When grayed out channel numbers are preset, these are highlighted and the “Preset Skip” setting changes to “On”.

Channel	Default settings
1 – 8	92.10 / 92.30 / 92.50 / 92.70 / 93.10 / 93.50 / 93.70 / 94.10 MHz
9 – 16	94.30 / 94.50 / 94.70 / 94.90 / 95.10 / 95.30 / 95.50 / 95.70 MHz
17 – 24	98.10 / 98.30 / 98.50 / 98.70 / 98.90 / 99.10 / 100.10 / 100.30 MHz
25 – 32	100.50 / 100.70 / 100.90 / 101.10 / 101.30 / 101.50 / 101.70 / 101.90 MHz
33 – 40	103.10 / 103.30 / 103.50 / 103.70 / 103.90 / 104.10 / 104.30 / 104.50 MHz
41 – 48	104.70 / 104.90 / 105.10 / 105.30 / 105.50 / 105.70 / 105.90 / 106.10 MHz
49 – 56	106.30 / 106.50 / 106.70 / 106.90 / 107.10 / 107.30 / 107.50 / 107.90 MHz

### Listening to preset stations

Use **CH/PAGE**  $\Delta \nabla$  to select the desired preset channel.

[Display of this unit]

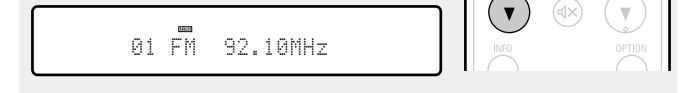

**□ Changing the tuning mode (Tune Mode)**

You can change the mode for tuning into FM broadcasts. If you cannot tune in automatically with “Auto” mode, then change the mode to “Manual” and tune in manually.

**1** Press **TUNER** to switch the input source to “TUNER”.

**2** Press **OPTION**.  
The option menu screen is displayed.

**3** Use **△▽** to select “Tune Mode”, then press **ENTER**.

[TV Screen]

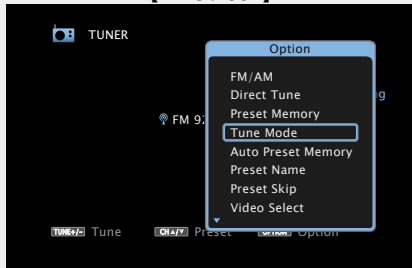

[Display of this unit]

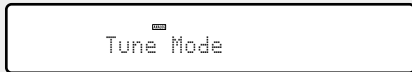

**4** Use **◀▶** to select tuning mode, then press **ENTER**.

[TV Screen]

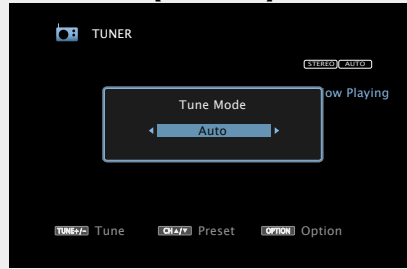

[Display of this unit]



**Auto** Automatically tune to the station.

**Manual** Manually tune to the station.



When tuning in stations manually, press and hold **TUNE +** or **TUNE -** to change frequencies continuously.

**□ Tuning in to radio stations and presetting them automatically (Auto Preset Memory)**

Up to 56 stations can be preset.

If "Auto Preset Memory" is performed after performing "Preset Memory", the "Preset Memory" settings will be overwritten.

**1** Press **TUNER** to switch the input source to "TUNER".

**2** Press **OPTION**.

The option menu screen is displayed.

**3** Use  $\Delta$ / $\nabla$  to select "Auto Preset Memory", then press **ENTER**.

[TV Screen]

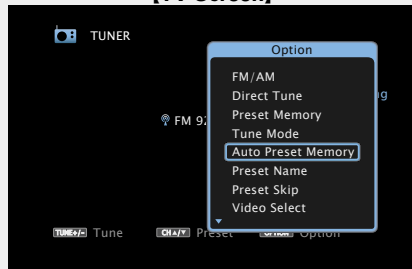

[Display of this unit]

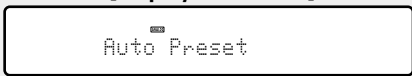

**4** Press **ENTER**.

The unit starts to tune in to radio stations automatically and preset them.

[TV Screen]

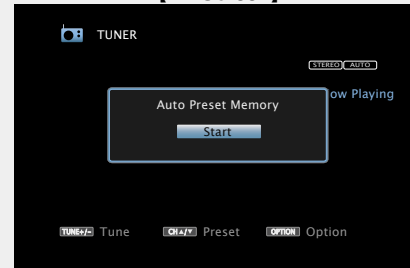

[Display of this unit]

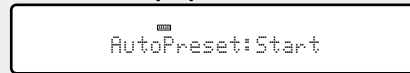

- When presetting is completed, "Completed" is displayed for about 5 seconds and the option menu screen turns off.



### Specify a name for the preset broadcast station (Preset Name)

You can set the name to the preset broadcast station or change it. Up to eight characters can be input.

#### 1 Press **TUNER** to switch the input source to “TUNER”.

#### 2 Press **OPTION**.

The option menu screen is displayed.

#### 3 Use $\Delta$ / $\nabla$ to select “Preset Name”, then press **ENTER**.

The Preset Name screen is displayed.

[TV Screen]

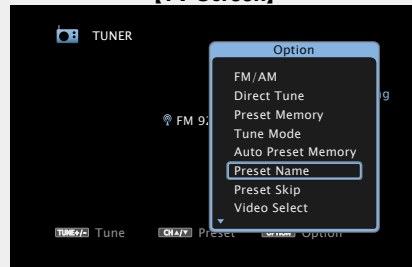

[Display of this unit]

Preset Name



#### 4 Use $\triangleleft$ / $\triangleright$ to select the group of the broadcast station you want to name then press **ENTER**.

The screen that lets you edit the preset name is displayed.

- Each time  $\triangleleft$ / $\triangleright$  is pressed, the setting is changed as shown below.

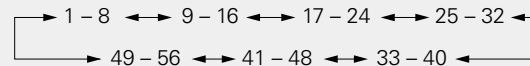

[TV Screen]

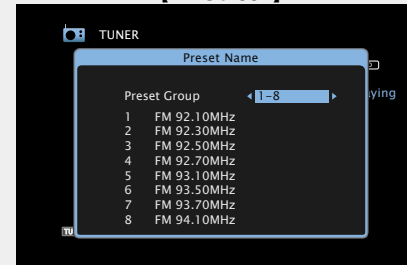

[Display of this unit]

GROUP : 1-8

#### 5 Use $\Delta$ / $\nabla$ to select the broadcast station you want to name, then press **ENTER**.

[TV Screen]

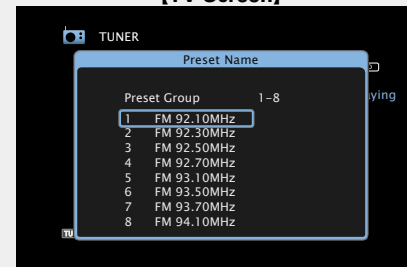

[Display of this unit]

1 FM 92.10MHz

#### 6 Use $\Delta$ / $\nabla$ to select a name label, then press **ENTER**.

The screen that lets you edit the preset name is displayed.

- If you select “Set Defaults”, then the unit returns to displaying the frequency.

#### 7 Enter the characters, then press **OK**.

- For character input, see [page 99](#).

#### 8 Press **BACK** twice.

The display returns to the playback screen.

### ❑ Skipping preset broadcast stations (Preset Skip)

You can set in advance, the stations you do not want to be displayed when tuning in, by groups or by stations.  
The preset skip setting is useful when tuning in, because only your favorite stations are displayed.

**1** Press **TUNER** to switch the input source to “TUNER”.

**2** Press **OPTION**.  
The option menu screen is displayed.

**3** Use  $\Delta$ / $\nabla$  to select “Preset Skip”, then press **ENTER**.  
The Preset Skip screen is displayed.

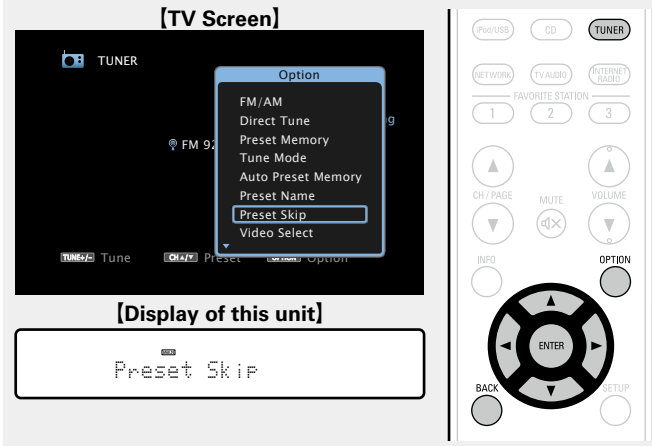

### 4-1 [To set the stations you want to skip by groups]

① Use  $\triangleleft$   $\triangleright$  to select the group of broadcast stations you want to skip.

- Each time  $\triangleleft$   $\triangleright$  is pressed, the setting is changed as shown below.

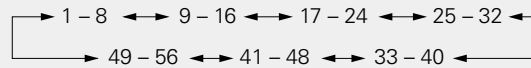

② Press  $\Delta$  to select “Set No.\* - \* to Skip”, then press **ENTER**.

All broadcast stations in the group “\* - \*” you selected are not displayed.

(\* are the selected group numbers)

③ Press **BACK**.

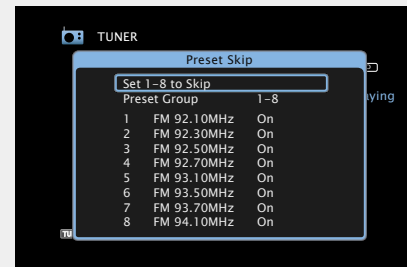
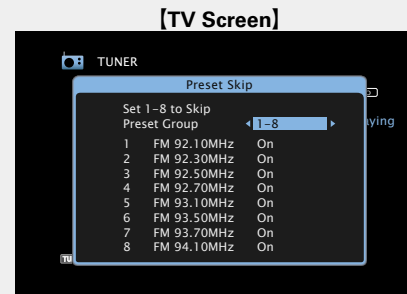

[Display of this unit]

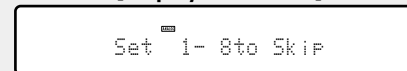

### 4-2 [To set the stations you want to skip by stations]

① Use  $\triangleleft$   $\triangleright$  to select the group of broadcast stations you want to skip.

- Each time  $\triangleleft$   $\triangleright$  is pressed, the setting is changed as shown below.

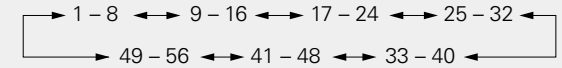

② Use  $\Delta$ / $\nabla$  to select the broadcast station you want to skip.

③ Use  $\triangleleft$   $\triangleright$  to select “Skip”.  
The station you selected is not displayed.

④ Press **BACK**.

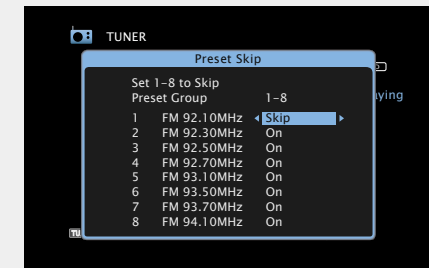
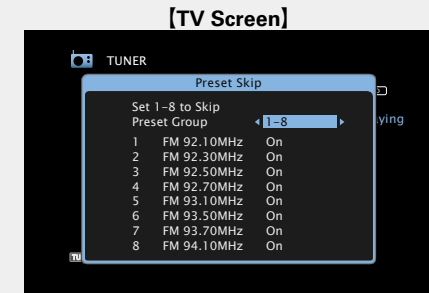

[Display of this unit]

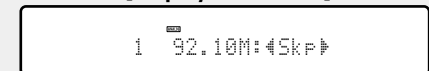

### ❏ Cancelling preset skip

**1** While the Preset Skip screen is displayed, use ◀ ▶ to select a group containing a broadcast station to cancel the skip for.

**2** Use △ ▽ to select a broadcast station to cancel the skip for.

[TV Screen]

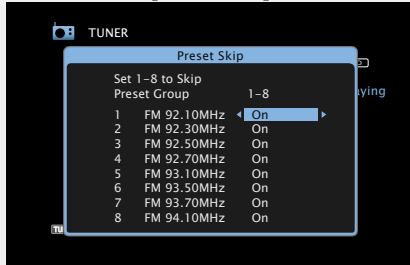

[Display of this unit]

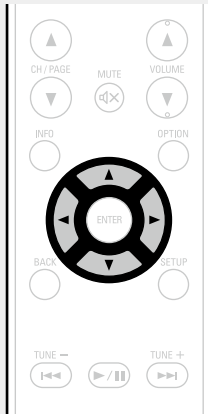
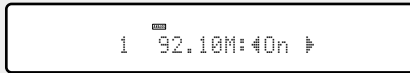

**3** Use ◀ ▶ to select “On”.  
The skip is cancelled.

**NOTE**

You cannot cancel the skip for each group.

### ❏ Tuner operation buttons

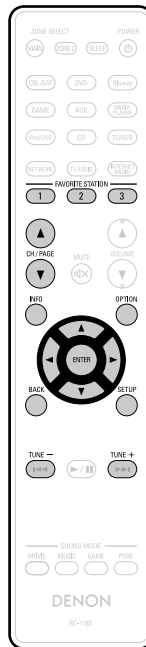

Operation buttons	Function
<b>FAVORITE STATION 1 – 3</b>	Call up favorite stations
<b>FAVORITE STATION 1 – 3</b> (Press and hold)	Add to the favorite stations
<b>CH/PAGE ▲▼</b>	Preset channel selection
<b>INFO</b>	Display of information such as the source name, volume, and sound mode name
<b>OPTION</b>	FM/AM switching Direct frequency tuning / Preset Memory / Switch tuning modes / Auto Preset Memory / Preset Name / Preset Skip / Video Select / All Zone Stereo
△▽◀▶	Cursor operation
<b>ENTER</b>	Enter
<b>BACK</b>	Return
<b>SETUP</b>	Setup menu
<b>TUNE +, –</b>	Tuning (up/down)

# Network content

## Listening to Internet Radio

Internet Radio refers to radio broadcasts distributed over the Internet. Internet Radio stations from around the world can be received.

### Important information

The broadcast station types and specifications supported by this unit for playback are as follows.

#### [Playable broadcast station types]

Supported file types	Internet Radio
<b>WMA</b> (Windows Media Audio)	✓
<b>MP3</b> (MPEG-1 Audio Layer-3)	✓

#### [Playable broadcast station specifications]

	Sampling frequency	Bit rate	Extension
<b>WMA</b> (Windows Media Audio)	32/44.1/48 kHz	48 – 192 kbps	.wma
<b>MP3</b> (MPEG-1 Audio Layer-3)	32/44.1/48 kHz	32 – 320 kbps	.mp3

## Listening to Internet Radio

### 1 Prepare for playback.

- ① Check the network environment, then turn on this unit's power (☞ [page 19](#) "Connecting to a home network (LAN)").
- ② If settings are required, make the "Settings" (☞ [page 121](#)).

### 2 Press NETWORK.

- You can also press **INTERNET RADIO** to select the input source "Internet Radio" directly.

### 3 Use $\Delta$ $\nabla$ $\triangleleft$ $\triangleright$ to select "Internet Radio", then press ENTER.

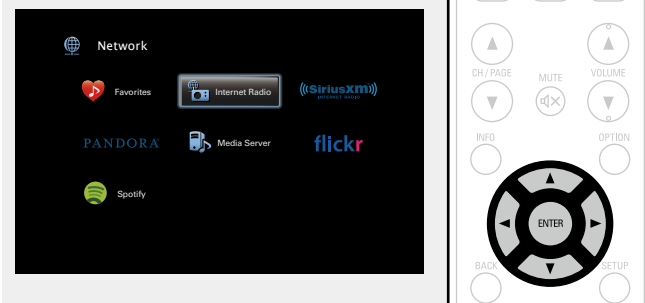

### 4 Use $\Delta$ $\nabla$ to select the item you want to play, then press ENTER or $\triangleright$ .

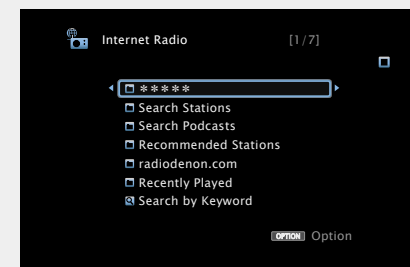

- \*\*\*\*\***  
(Country name) Displays typical Internet Radio stations your country.
- Search Stations** Displays all Internet Radio stations that this unit can tune in to.
- Search Podcasts** Displays Internet Radio stations in the podcasts that this unit can tune in to.
- Recommended Stations** Displays recommended Internet Radio stations.
- radiodnon.com** Displays Internet Radio stations added to favorites in vTuner. For instructions on how to add to favorites in vTuner, see "Using vTuner to add Internet Radio stations to favorites" (☞ [page 47](#)).
- Recently Played** Displays recently played Internet Radio stations. Up to 20 stations stored in "Recently Played".
- Search by Keyword** Displays Internet Radio stations searched by keyword. For character input, see [page 99](#).

### 5 Repeat step 4 until the station list is displayed.

The station list is displayed.

### 6 Use $\Delta$ $\nabla$ to select the station, then press ENTER or $\triangleright$ .

Playback starts once buffering reaches "100%".

### ❑ Adjusting the sound quality (Restorer)

Make this setting at "Restorer" ([page 103](#)) in the menu.

You can use the Restorer function to improve the fidelity of compressed audio sources such as content from Internet Radio stations. The Restorer has selectable levels of restoration. The default setting is "Low".

### ❑ Switching the screen display

Press **STATUS** on the main unit.

The display switches between track title and radio station name etc. each time the button is pressed.

### ❑ Going back to the previous screen

Press ◀ or **BACK**.

### ❑ Changing the screen display duration

Make this setting at "Now Playing" ([page 110](#)) in the menu. The default setting is "Always On".

When "Auto Off" is set, the on-screen display is turned off 30 seconds after an operation.

Press △▽◀▶ while the display is off to return to the original screen.



- There are many Internet Radio stations on the Internet, and the quality of the programs they broadcast as well as the bit rate of the tracks varies widely.

Generally, the higher the bit rate, the higher the sound quality, but depending on the communication lines and server traffic, the music or audio signals being streamed may be interrupted. Inversely, lower bit rates mean a lower sound quality but less tendency for the sound to be interrupted.

- "Radio station server full" or "Connection down" is displayed if the station is busy or not broadcasting.

- On this unit, folder and file names can be displayed as titles. Any characters that cannot be displayed are replaced with "." (period).

#### NOTE

The radio station database service may be suspended or be otherwise unavailable without notice.

### Operations available through the OPTION button

Press the **OPTION** button to display a menu of functions that can be used on the TV screen. Select the function you want to use from this menu. You can easily find and use the desired function.

❑ **Searching content with keywords (Text Search)** ([page 63](#))

❑ **Add to favorites from the Option menu (Save to Favorites)** ([page 65](#))

❑ **Playing back music and a favorite picture at the same time (Slideshow)** ([page 66](#))

❑ **Displaying your desired video on the monitor during audio playback (Video Select)** ([page 67](#))

❑ **Adjusting the picture quality for your viewing environment (Picture Mode)** ([page 67](#))

❑ **All Zone Stereo function** ([page 68](#))

### ❑ Playing the last played Internet Radio station

This unit memorizes the last played Internet Radio station. If you press **INTERNET RADIO** to switch to the Internet Radio function from another input source, the last Internet Radio station you listened to is played.

#### Press INTERNET RADIO.

The source switches to "Internet Radio" and the last played radio station plays.



## ❑ Using vTuner to add Internet Radio stations to favorites

There are many Internet Radio stations in the world, and this unit can tune into these stations. But finding the radio station you want to hear may be difficult, because there are too many stations. If this is the case, then please use vTuner, an Internet Radio station search website specifically designed for this unit. You can use your PC to search Internet Radio stations and add them as your favorites. This unit can play radio stations added to vTuner.

### 1 Check the MAC address of this unit (page 120).

The screen that lets you edit the preset name is displayed.  
MAC address:

- The MAC address is necessary when you create an account for vTuner.

### 2 Use your PC to access the vTuner website (<http://www.radiodenon.com>).

The vTuner login screen is displayed.

### 3 Enter the MAC address of this unit, then click “Go”.

The account creation screen is displayed.

### 4 Enter your E-mail address and a password of your choice.

The account is registered and you can now log in.

### 5 Enter your account information (E-mail address and password) and log in.

The top menu of vTuner is displayed.

### 6 Select the search criteria (genre, region, language, etc.) of your choice.

The list of radio stations matching the criteria is displayed.

- You can also enter a keyword to search for a station you want to hear.

### 7 Select the radio station of your choice from the list, and then click the Add to Favorites icon.

The screen that lets you create a favorite group is displayed.

### 8 Enter the name of the favorite group, then click “Go”.

A new favorite group that includes the selected radio station is created.

- Internet Radio stations added to favorites in vTuner can be played from “radiodenon.com” (page 45) with this unit.

## ❑ Internet Radio operation buttons

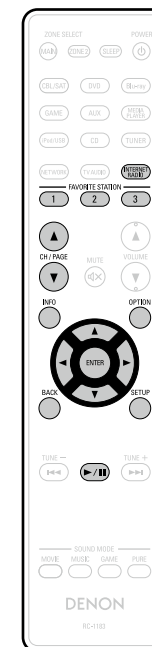

Operation buttons	Function
<b>INTERNET RADIO</b>	Last played Internet Radio station
<b>FAVORITE STATION 1 – 3</b>	Call up favorite stations
<b>FAVORITE STATION 1 – 3</b> (Press and hold)	Add to the favorite stations
<b>CH/PAGE ▲▼</b>	Page search
<b>INFO</b>	Display of information such as the source name, volume, and sound mode name
<b>OPTION</b>	Text Search / Save to Favorites / Slideshow / Video Select / Picture Mode / All Zone Stereo
△▽◀▶	Cursor operation
<b>ENTER</b> (Press and release)	Enter
<b>ENTER</b> (Press and hold)	Stop
<b>BACK</b>	Return
<b>SETUP</b>	Setup menu
<b>▶/II</b>	Playback / Stop

## Playing back files stored on a PC and NAS

This unit can play back music files and playlists (m3u, wpl) stored on a PC and on Network Attached Storage (NAS) that supports DLNA.

### Important information

- The network audio playback function of this unit connects to the server using technologies shown below.
  - Windows Media Player Network Sharing Service
  - Windows Media DRM10
- File types that this unit can play back and specifications are shown below.

#### [Supported file types]

Supported file types	Media Server *1
<b>WMA</b> (Windows Media Audio)	✓
<b>MP3</b> (MPEG-1 Audio Layer-3)	✓
<b>WAV</b>	✓
<b>MPEG-4 AAC</b>	✓*2
<b>FLAC</b> (Free Lossless Audio Codec)	✓
<b>JPEG</b>	✓
<b>ALAC</b> (Apple Lossless Audio Codec)	✓

A server or server software compatible with distribution in the corresponding formats is required to play music files via a network.

\*1 Media Server

- This unit is compatible with MP3 ID3-Tag (Ver. 2) standard.
- This unit can show the artwork that was embedded by using MP3 ID3-Tag Ver. 2.3 or 2.4.
- This unit is compatible with WMA META tags.
- If the image size (pixels) of an album artwork exceeds 500 × 500 (WMA/MP3/WAV/FLAC) or 349 × 349 (MPEG-4 AAC), then music may not be played back properly.
- WAV format Quantization bit length: 16 or 24 bits.
- FLAC format Quantization bit length: 16 or 24 bits.

\*2 Only files that are not protected by copyright can be played on this unit.

Content downloaded from pay sites on the Internet are copyright protected. Also, files encoded in WMA format when ripped from a CD, etc. on a computer may be copyright protected, depending on the computer's settings.

#### NOTE

File types that this unit does not support are not displayed.

#### [Specifications of supported files]

	Sampling frequency	Bit rate	Extension
<b>WMA</b> (Windows Media Audio)	32/44.1/48 kHz	48 – 192 kbps	.wma
<b>MP3</b> (MPEG-1 Audio Layer-3)	32/44.1/48 kHz	32 – 320 kbps	.mp3
<b>WAV</b>	32/44.1/48/88.2/96/ 176.4/192 kHz	–	.wav
<b>MPEG-4 AAC</b>	32/44.1/48 kHz	16 – 320 kbps	.aac/ .m4a/ .mp4
<b>FLAC</b> (Free Lossless Audio Codec)	32/44.1/48/88.2/96/ 176.4/192 kHz	–	.flac
<b>ALAC</b> (Apple Lossless Audio Codec)*	32/44.1/48/88.2/96 kHz	–	.m4a

\* Copyright [2012] [D&M Holdings. Inc.]

Licensed under the Apache License, Version 2.0 (the "License"); you may not use this file except in compliance with the License. You may obtain a copy of the License at <http://www.apache.org/licenses/LICENSE-2.0>

## Applying media sharing settings

Here, we apply the settings to share music files stored on a PC and NAS on the network.

### Sharing media stored in PC

If you are using a Media Server, be sure to apply this setting first.

### When using Windows Media Player 12 (Windows 7 / Windows 8)

#### NOTE

Perform this procedure after changing the control panel display to "Category".

- 1** In the PC's "Control Panel", select "Network and Internet" - "Choose homegroup and sharing options".
- 2** Select the "Stream my pictures, music, and videos to all devices on my home network" check box and select "Choose media streaming options".
- 3** Select "Allowed" in the drop-down list for "AVR-E400".
- 4** Select "Allowed" in the drop-down list for "Media programs on this PC and remote connections...".
- 5** Click "OK" to finish.

### When using Windows Media Player 11

- 1** Start up Windows Media Player 11 on the PC.
- 2** Select "Media Sharing" in the "Library".
- 3** Click the "Share my media" check box, select "AVR-E400", and then click "Allow".
- 4** As you did in step 3, select the icon of the device (other PCs and mobile devices) you want to use as a media controller, and then click "Allow".
- 5** Click "OK" to finish.

### Sharing media stored in NAS

Change settings on the NAS to allow this unit and other devices (PCs and mobile devices) used as media controllers to access the NAS. For details, see the owner's manual that came with the NAS.



## Playing back files stored on a PC and NAS

Use this procedure to play music files, image files or playlists.

### 1 Prepare for playback.

- ① Check the network environment, then turn on this unit's power (page 19 "Connecting to a home network (LAN)").
- ② If settings are required, make the "Settings" (page 121).
- ③ Prepare the computer (Computer's operating instructions).

### 2 Press NETWORK.

### 3 Use $\Delta$ $\nabla$ $\triangleleft$ $\triangleright$ to select "Media Server", then press ENTER.

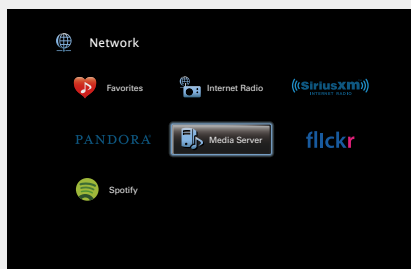

### 4 Use $\Delta$ $\nabla$ to select the server including the file to be played, then press ENTER or $\triangleright$ .

### 5 Use $\Delta$ $\nabla$ to select the search item or folder, then press ENTER or $\triangleright$ .

### 6 Repeat step 4 until the file is displayed.

### 7 Use $\Delta$ $\nabla$ to select the file, then press ENTER or $\triangleright$ . Playback starts once buffering reaches "100%".

### Adjusting the sound quality (Restorer)

Make this setting at "Restorer" (page 103) in the menu.

You can use the Restorer function to improve the fidelity of compressed audio sources such as MP3 files. The Restorer has selectable levels of restoration. The default setting is "Low".

### Switching the screen display

Press **STATUS** on the main unit.

The display switches between track title, artist name, and album title each time the button is pressed.

### Going back to the previous screen

Press  $\triangleleft$  or **BACK**.

### Changing the screen display duration

Make this setting at "Now Playing" (page 110) in the menu. The default setting is "Always On".

When "Auto Off" is set, the on-screen display is turned off 30 seconds after an operation.

Press  $\Delta$  $\nabla$  $\triangleleft$  $\triangleright$  while the display is off to return to the original screen.



- When a WMA (Windows Media Audio), MP3 or MPEG-4 AAC file includes album art data, the album art can be displayed while the music files are playing.
- If you use Ver.11 or later of Windows Media Player, the album art for WMA files can be displayed.
- WMA Lossless files can be played when using a server supporting transcoding, such as Windows Media Player Ver. 11 or later.

### NOTE

- When playing back music files with your PC or NAS connected through wireless LAN, audio may be interrupted depending on your wireless LAN environment. In this case, play back music files with your PC or NAS connected through wired LAN.
- Depending on the size of the still picture (JPEG) file, some time may be required for the file to be displayed.
- The order in which the tracks/files are displayed depends on the server specifications. If the tracks/files are not displayed in alphabetical order due to the server specifications, searching by the first letter may not work properly.

### Operations available through the OPTION button

Press the **OPTION** button to display a menu of functions that can be used on the TV screen. Select the function you want to use from this menu. You can easily find and use the desired function.

❑ **Searching content with keywords (Text Search)** (👉 [page 63](#))

❑ **Performing repeat playback (Repeat)** (👉 [page 63](#))

❑ **Performing random playback (Random)** (👉 [page 64](#))

❑ **Playing back still images in sequential order (Slideshow Interval)** (👉 [page 66](#))

❑ **Add to favorites from the Option menu (Save to Favorites)** (👉 [page 65](#))

❑ **Playing back music and a favorite picture at the same time (Slideshow)** (👉 [page 66](#))

❑ **Displaying your desired video on the monitor during audio playback (Video Select)** (👉 [page 67](#))

❑ **Adjusting the picture quality for your viewing environment (Picture Mode)** (👉 [page 67](#))

❑ **All Zone Stereo function** (👉 [page 68](#))

### ❑ Media Server operation buttons



Operation buttons	Function
<b>FAVORITE STATION 1 – 3</b>	Add/call up favorite stations
<b>FAVORITE STATION 1 – 3 (Press and hold)</b>	Add to the favorite stations
<b>CH/PAGE ▲▼</b>	Page search
<b>INFO</b>	Display of information such as the source name, volume, and sound mode name
<b>OPTION</b>	Text Search / Repeat playback / Random playback / Slideshow Interval / Save to Favorites / Slideshow / Video Select / Picture Mode / All Zone Stereo
△▽◀▶	Cursor operation / Next/Previous (△▽) / Fast-forward/Fast-reverse (Press and hold, △▽)*
<b>ENTER (Press and release)</b>	Enter
<b>ENTER (Press and hold)</b>	Stop
<b>BACK</b>	Return
<b>SETUP</b>	Setup menu
<b>⏪ ⏩ (Press and release)</b>	Next/Previous
<b>⏪ ⏩ (Press and hold)</b>	Fast-forward/Fast-reverse*
<b>▶/⏸</b>	Playback / Pause

\* This function is available while an MP3 / WAV / AAC / FLAC file is being played back.

## Using online services

This unit supports playback of the online services shown below.

### ❑ About Flickr (👉 page 53)

Flickr is an online photograph sharing service that started in 2004. You can use this unit to view photographs that have been made public by Flickr users. You do not need an account to use Flickr. To view photographs that you recorded yourself, you need an account in order to upload these photographs to the Flickr server. For details, see the Flickr homepage.  
<http://www.flickr.com/>

### ❑ About Pandora® (👉 page 55)

Pandora is an automated music recommendation and Internet Radio service created by the Music Genome Project. To listen to Pandora you will need a free Pandora account. If you do not have a Pandora account, you can create one at [www.pandora.com](http://www.pandora.com) or from the Pandora smartphone application. It is necessary to associate this machine with a Pandora account by visiting <http://www.pandora.com/denon> from your PC.

### ❑ About SiriusXM (👉 page 59)

Enjoy anywhere access to the unparalleled content of SiriusXM. Whether on your computer, smartphone, tablet, Lynx Portable Enjoy anywhere access to the unparalleled content of SiriusXM. Whether on your computer, smartphone, tablet, Lynx Portable Radio, or compatible Internet-connected device, you don't need to be in your vehicle to enjoy SiriusXM. For details, see the SiriusXM homepage.  
<http://www.siriusxm.com>

### ❑ About Spotify (👉 page 61)

Introduce your Denon to a whole new world of music. With Spotify, you can enjoy instant access to millions of songs. A Spotify Premium subscription is required. For details, see the Spotify homepage.  
<http://www.spotify.com>

## Viewing photographs on the Flickr site

You can view photographs shared by particular users, or all of the photographs shared on Flickr.

### Viewing photographs shared by particular users

#### 1 Prepare for playback.

- ① Check the network environment, then turn on this unit's power (☞ [page 19](#) "Connecting to a home network (LAN)").
- ② If settings are required, make the "Settings" (☞ [page 121](#)).

#### 2 Press NETWORK.

#### 3 Use $\Delta$ $\nabla$ $\triangleleft$ $\triangleright$ to select "Flickr", then press ENTER.

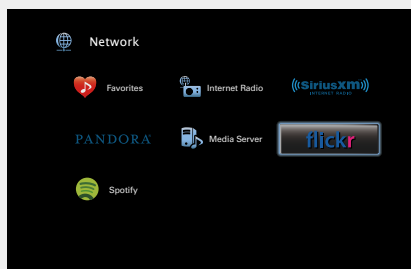

#### 4 Use $\Delta$ $\nabla$ to select "Add Flickr Contact", then press ENTER or $\triangleright$ .

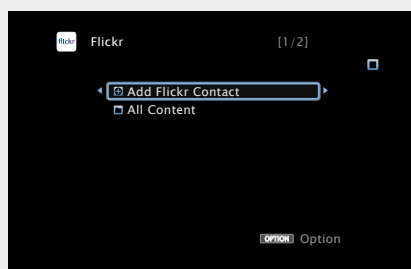

#### 5 In "Contact", add the screen name (user name you want to view) you want to add.

- For character input, see [page 99](#).

#### 6 After inputting the "Contact", press **OK**.

The screen name is added to "Contact", and the screen name you entered in Step 5 is displayed on the top screen of Flickr.

- If you enter a screen name that does not exist, "The Flickr Contact you entered could not be found" is displayed. Check and enter the correct screen name.

#### 7 Use $\Delta$ $\nabla$ to select the folder, and then press ENTER or $\triangleright$ .

- Favorites** Displays the favorite photographs of the specified user.
- Photostream** Displays a list of shared photographs.
- PhotoSets** Displays the folder (photograph album) list.
- Contacts** Displays the screen name used by the specified user in Contacts.
- Remove this Contact** Deletes a user from Flickr Contact.
- Add this Contact** Adds a user from Flickr Contact.

#### 8 Use $\Delta$ $\nabla$ to select the file, and then press ENTER or $\triangleright$ .

The selected file is displayed.

#### Going back to the previous screen

Press  $\triangleleft$  or **BACK**.

#### Operations available through the OPTION button

Press the **OPTION** button to display a menu of functions that can be used on the TV screen. Select the function you want to use from this menu. You can easily find and use the desired function.

Playing back still images in sequential order (Slideshow Interval) (☞ [page 66](#))

Displaying your desired video on the monitor during audio playback (Video Select) (☞ [page 67](#))

Adjusting the picture quality for your viewing environment (Picture Mode) (☞ [page 67](#))

All Zone Stereo function (☞ [page 68](#))

### □ Viewing all photographs on Flickr

**1** Use  $\Delta$ / $\nabla$  to select “All Content”, then press **ENTER** or  $\triangleright$ .

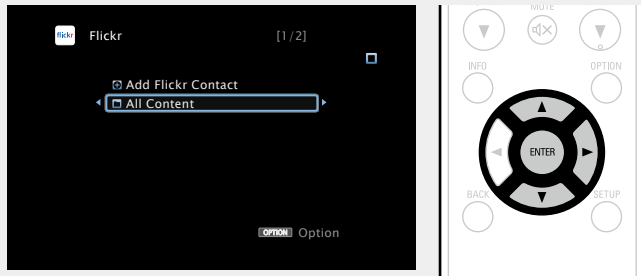

**2** Use  $\Delta$ / $\nabla$  to select the folder, and then press **ENTER** or  $\triangleright$ .

**Interestingness** Displays photographs that are popular from the number of user comments or number of times they are added as favorites.

**Recent** Displays the most recently added photographs.

**Search by text** Search for photographs by keyword.

**3** Use  $\Delta$ / $\nabla$  to select the file, and then press **ENTER** or  $\triangleright$ .  
The selected file is displayed.

**NOTE**

Depending on the file format, some photographs may not be viewable.

### □ Flickr operation buttons

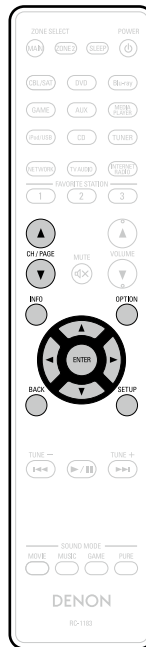

Operation buttons	Function
<b>CH/PAGE</b> $\Delta$ / $\nabla$	Page search
<b>INFO</b>	Display of information such as the source name, volume, and sound mode name
<b>OPTION</b>	Video Select / Picture Mode / All Zone Stereo
$\Delta$ / $\nabla$ / $\triangleleft$ / $\triangleright$	Cursor operation / Next/Previous ( $\Delta$ / $\nabla$ )
<b>ENTER</b> (Press and release)	Enter
<b>ENTER</b> (Press and hold)	Stop
<b>BACK</b>	Return
<b>SETUP</b>	Setup menu

## Listening to Pandora®

### 1 Prepare for playback.

- ① Check the network environment, then turn on this unit's power (refer to [page 19](#) "Connecting to a home network (LAN)").
- ② If settings are required, make the "Settings" (refer to [page 121](#)).
- ③ Complete step 4 and obtain a Pandora account.
  - If you already have a Pandora account, you do not need to obtain a new account. Use your existing Pandora account.

### 2 Press NETWORK.

### 3 Use $\Delta \nabla \triangleleft \triangleright$ to select "Pandora", then press ENTER.

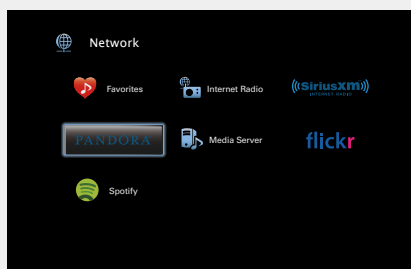

### 4 If you have a Pandora account, use $\Delta \nabla$ to select "I have a Pandora account", then press ENTER or $\triangleright$ .

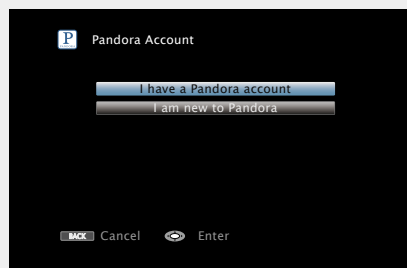

- If you do not have a Pandora account, press  $\nabla$  to select "I am new to Pandora". The URL of Pandora and activation code are displayed. Access the Pandora web page from your PC and register the displayed activation code and account information. Then press ENTER.

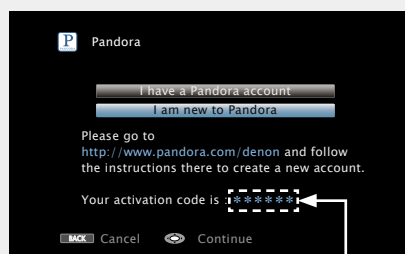

This is an identification code required to register your purchased product to the Pandora service.  
This code is used to obtain your account.

### 5 Input "Email address" and "Password".

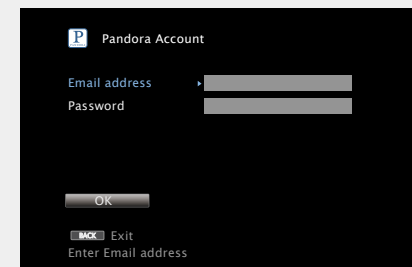

- For character input, see [page 99](#).

### 6 After inputting the "Email address" and "Password", select "OK", then press ENTER.

If the "Email address" and "Password" match, the top menu for Pandora is displayed.

#### NOTE

Press **BACK** to cancel the input. When "Cancel Input?" is displayed, select "Yes", then press **ENTER**.

## Operations available through the OPTION button

Press the **OPTION** button to display a menu of functions that can be used on the TV screen. Select the function you want to use from this menu. You can easily find and use the desired function.

❑ **Displaying your desired video on the monitor during audio playback (Video Select)** (👉 [page 67](#))

❑ **Adjusting the picture quality for your viewing environment (Picture Mode)** (👉 [page 67](#))

❑ **All Zone Stereo function** (👉 [page 68](#))

## ❑ Creating a new station

You can create up to 100 radio stations.

**1** Use  $\Delta$ / $\nabla$  to select “New Station”, then press **ENTER** or  $\triangleright$ .

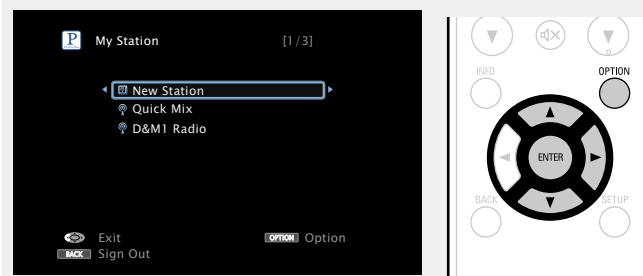

**2** Input a track or artist name, then press **OK**.

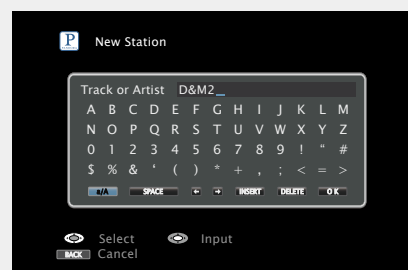

• For character input, see [page 99](#).

**3** Use  $\Delta$ / $\nabla$  to select “Search by Artist” or “Search by Track”, then press **ENTER**.

You can search and display a list by track or artist.

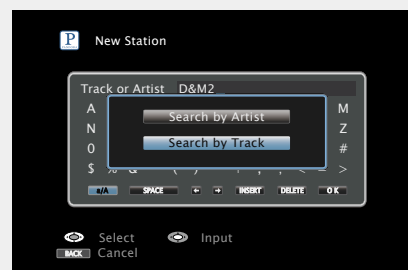

**4** Press  $\Delta$ / $\nabla$ , select a file (e.g. D&M2) from the list, and press **ENTER** or  $\triangleright$ .

“Radio” is added to the end of a filename, and your new station is created (e.g. D&M2 Radio).

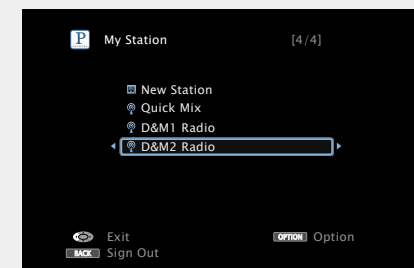

• Your new station will play music with similar qualities to the artist or track you entered.

## Listening to an existing station

Use  $\triangle$ / $\nabla$  and select the radio station (“D&M2 Radio”) that you want to listen to, and press **ENTER** or  $\triangleright$ .

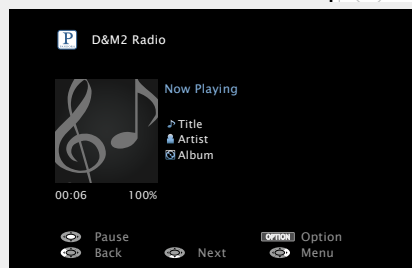
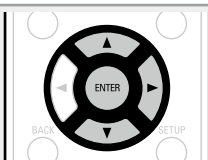

## Listening to created radio stations at random

Use  $\triangle$ / $\nabla$  to select “Quick Mix”, then press **ENTER** or  $\triangleright$ .

Created radio stations are selected at random, and tracks are streamed.

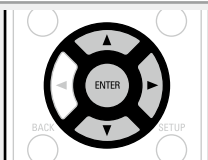

## Giving Feedback and Managing Stations

You can personalize your stations by providing feedback.

Press  $\triangleright$  while a track is playing.

The Pandora menu screen is displayed.

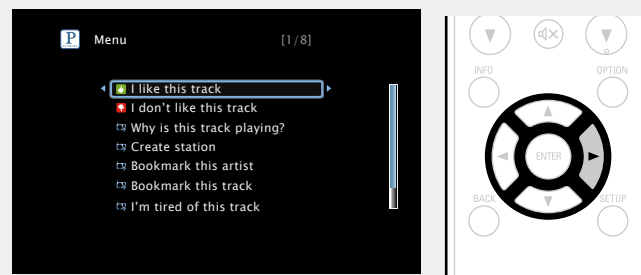

### I like this track

- Press when you like the track that is being played.
- It will return to the Play Screen. And (Thumbs up) icon is displayed. (The icon is not displayed on the next track.)

### I don't like this track

- Press when you don't like the track that is being played.
- It will return to the Play Screen. And (Thumbs down) icon is displayed. (The icon is not displayed on the next track.)

### Why is this track playing?

- Displays the reason why Pandora selected this track.

### Create station

- Creates a Station for the Track or Artist being played.

### Bookmark this artist

- Bookmarks the artist currently being played.
- You can check on a computer or iPhone etc.
- For details, see the Pandora web page.

### Bookmark this track

- Bookmarks the track currently being played.
- You can check on a computer or iPhone etc.
- For details, see the Pandora web page.

### I'm tired of this track

- Press when you don't like the track that is being played.
- The track will not be played for 1 month.

### Delete this station

- Press when you want to delete the station that is being played.

## NOTE

- You can Skip up to 6 Tracks that are being played back within 1 hour.
- You can create up to 100 Stations (radio stations).

## Sign out

Disassociate this unit from your Pandora account.

### 1 While the Pandora top menu is displayed, press **BACK**.

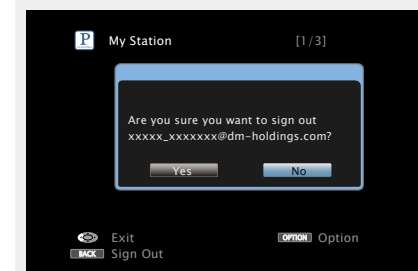

### 2 When the popup menu appears, use $\triangleleft$ / $\triangleright$ to select “Yes”, then press **ENTER**.

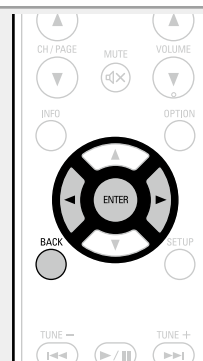



□ Pandora operation buttons

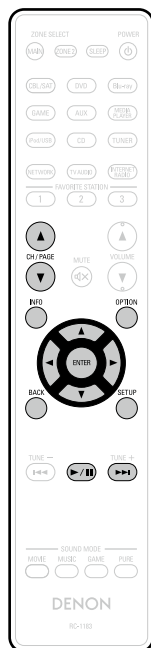

Operation buttons	Function
<b>CH/PAGE ▲▼</b>	Page search
<b>INFO</b>	Display of information such as the source name, volume, and sound mode name
<b>OPTION</b>	Video Select / Picture Mode / All Zone Stereo
△▽◀▶	Cursor operation / Skips the current track, subject to skip limit (▽)
<b>ENTER</b> (Press and release)	Enter
<b>ENTER</b> (Press and hold)	Stop
<b>BACK</b>	Return
<b>SETUP</b>	Setup menu
▶/	Playback / Pause
▶▶	Skips the current track, subject to skip limit

## Listening to SiriusXM Internet Radio

Over 120 channels of the SiriusXM programming you love, including commercial-free music plus sports, talk, news and entertainment. Listen anywhere on your computer or smartphone.

### 1 Prepare for playback.

- ① Check the network environment, then turn on this unit's power (☞ [page 19](#) "Connecting to a home network (LAN)").
- ② If settings are required, make the "Settings" (☞ [page 121](#)).
- ③ Access the following website from your PC and obtain a SiriusXM account.  
<http://www.siriusxm.com>
  - If you already have a SiriusXM account, you do not need to obtain a new account. Select "Sign in" in step 4, and enter your existing SiriusXM account.

### 2 Press NETWORK.

### 3 Use $\Delta$ $\nabla$ $\triangleleft$ $\triangleright$ to select "SiriusXM", then press ENTER.

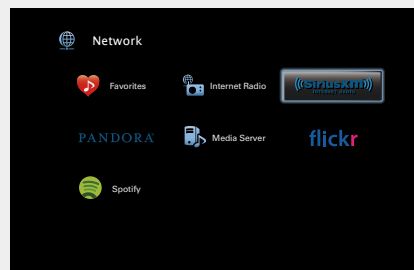

### 4 Select "Sign in", then press ENTER.

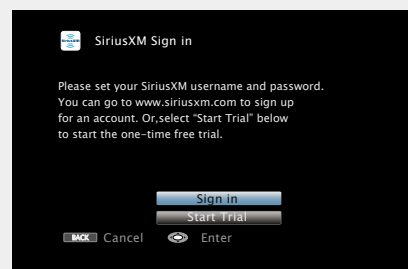

### 5 Input the "Username" and "Password".

- For character input, see [page 99](#).

### 6 Select the "Sign in", and then press ENTER.

The top menu of SiriusXM is displayed.



### 7 Use $\Delta$ $\nabla$ to select the genre, then press ENTER or $\triangleright$ .

### 8 Use $\Delta$ $\nabla$ to select the file, and then press ENTER or $\triangleright$ .

The selected file is displayed.

- ☐ **Going back to the previous screen**  
Press  $\triangleleft$  or **BACK**.

### Operations available through the OPTION button

Press the **OPTION** button to display a menu of functions that can be used on the TV screen. Select the function you want to use from this menu. You can easily find and use the desired function.

- ☐ **Displaying your desired video on the monitor during audio playback (Video Select)** (☞ [page 67](#))

- ☐ **Adjusting the picture quality for your viewing environment (Picture Mode)** (☞ [page 67](#))

- ☐ **All Zone Stereo function** (☞ [page 68](#))

## ❑ Sign out

Disassociate this unit from your SiriusXM account.

**1** While the SiriusXM top menu is displayed, press **BACK**.

**2** When the popup menu appears, use **◀ ▶** to select "Yes", then press **ENTER**.



## ❑ SiriusXM operation buttons

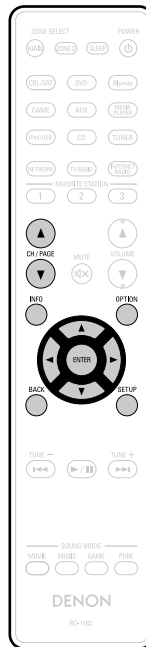

Operation buttons	Function
<b>CH/PAGE ▲▼</b>	Page search
<b>INFO</b>	Display of information such as the source name, volume, and sound mode name
<b>OPTION</b>	Video Select / Picture Mode / All Zone Stereo
<b>△▼◀▶</b>	Cursor operation
<b>ENTER</b> (Press and release)	Enter
<b>ENTER</b> (Press and hold)	Stop
<b>BACK</b>	Return
<b>SETUP</b>	Setup menu

## Listening to Spotify

Introduce your Denon to a whole new world of music. With Spotify, you can enjoy instant access to millions of songs.

A Spotify Premium subscription is required.

For details, see the Spotify homepage.

<http://www.spotify.com>

### 1 Prepare for playback.

- Check the network environment, then turn on this unit's power (refer [page 19](#) "Connecting to a home network (LAN)").
- If settings are required, make the "Settings" (refer [page 121](#)).
- Complete step 5 and obtain a Spotify account.
  - If you already have a Spotify account, you do not need to obtain a new account. Use your existing Spotify account.

### 2 Press NETWORK.

### 3 Use $\Delta \nabla \triangleleft \triangleright$ to select "Spotify", then press ENTER.

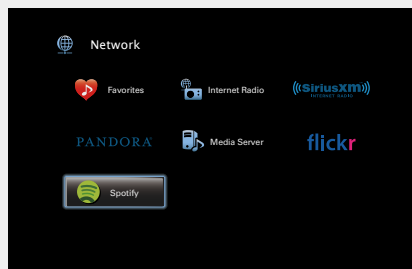

### 4 If you have a Spotify account, then press ENTER.

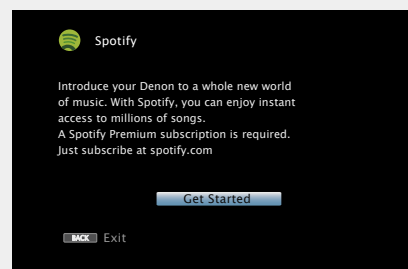

### 5 Use $\Delta \nabla \triangleright$ to enter your username and password.

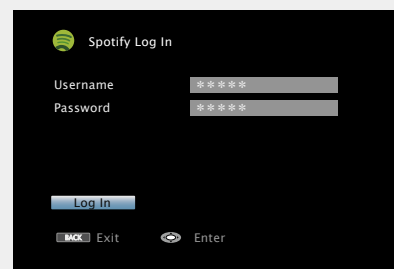

- The password should be no longer than 99 characters. For character input, see [page 99](#).
- The types of characters that can be input are as shown below.

**[Upper case characters/Numbers/Symbols]**  
 ABCDEFGHIJKLMNOPQRSTUVWXYZ  
 ÅÄÅÄÅÄÆÇÐÈÉÊËÌÍÎÏÑÒÓÔÕÖØÙÚÛÜÝ  
 0123456789  
 ! " # \$ % & ' ( ) \* + , ; < = >

**[Lower case characters/Numbers/Symbols]**  
 abcdefghijklmnopqrstuvwxyz  
 åäååååæçðèéêëìíîïñòóôõöøùúûýþÿ  
 0123456789  
 . @ - \_ / : ~ ? [ \ ] ^ ' { | }

- When you use  $\Delta \nabla$  while you type in, you can change uppercase characters to lowercase and vice versa.
- Press **BACK** to cancel the input. When "Cancel input?" is displayed, select "Yes", then press **ENTER**.

### 6 After inputting the username and password, select "Log In", then press ENTER.

If the username and password match, the top menu for Spotify is displayed.

### 7 Use $\Delta \nabla$ to select menu and then press ENTER.

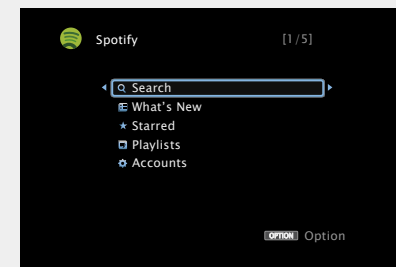

**Search** Searches for tracks, artists and albums by entering keywords.

**What's New** Displays the list of the latest albums.

**Starred** Displays the list of the starred tracks.

**Playlists** Displays the playlists for Spotify.

**Accounts** Manages accounts (Log out, Add new user, Switch to user).

### 8 Use $\Delta \nabla$ to select a station, and press ENTER or $\blacktriangleright / \parallel$ to start playback.

Playback starts and the following screen appears.

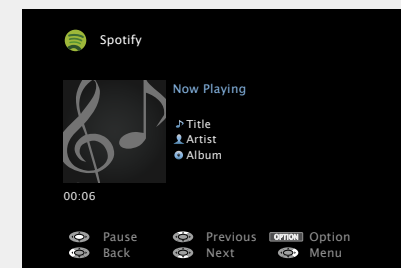

## 9 Press **▷** while a track is playing.

The Spotify menu screen is displayed.

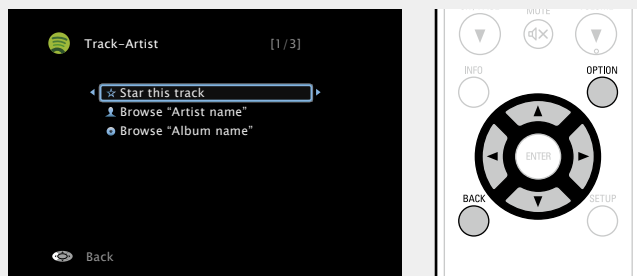

**Star this track** Adds a star to the selected track.

**Browse "Artist name"** Displays the list of albums by the artist of the track that is being played back.

**Browse "Album name"** Displays the list of tracks on the album that is being played back.

### ❑ **Adjusting the sound quality (Restorer)**

Make this setting at "Restorer" ([page 103](#)) in the menu.

You can use the Restorer function to improve the fidelity of compressed audio sources such as content from streaming music services. The Restorer has selectable levels of restoration. The default setting is "Low".

### ❑ **Switching the screen display**

Press **STATUS** on the main unit.

The display switches between track title, artist name, and album title each time the button is pressed.

### ❑ **Going back to the previous screen**

Press **◀** or **BACK**.

### ❑ **Changing the screen display duration**

Make this setting at "Now Playing" ([page 110](#)) in the menu.

The default setting is "Always On".

When "Auto Off" is set, the on-screen display is turned off 30 seconds after an operation.

Press **△▽◀▷** while the display is off to return to the original screen.

## Operations available through the **OPTION** button

Press the **OPTION** button to display a menu of functions that can be used on the TV screen. Select the function you want to use from this menu. You can easily find and use the desired function.

### ❑ **Performing repeat playback (Repeat)**

([page 63](#))

### ❑ **Performing random playback (Random)**

([page 64](#))

### ❑ **Displaying your desired video on the monitor during audio playback (Video Select)**

([page 67](#))

### ❑ **Adjusting the picture quality for your viewing environment (Picture Mode)**

([page 67](#))

### ❑ **All Zone Stereo function**

([page 68](#))

## ❑ **Spotify operation buttons**



Operation buttons	Function
<b>CH/PAGE ▲▼</b>	Page search
<b>INFO</b>	Display of information such as the source name, volume, and sound mode name
<b>OPTION</b>	Repeat playback / Random playback / Video Select / Picture Mode / All Zone Stereo
<b>△▽◀▷</b>	Cursor operation / Next/Previous (△▽) / Fast-forward/Fast-reverse (Press and hold, △▽)
<b>ENTER</b> (Press and release)	Enter
<b>ENTER</b> (Press and hold)	Stop
<b>BACK</b>	Return
<b>SETUP</b>	Setup menu
<b>⏮ ⏭</b> (Press and release)	Next/Previous
<b>⏮ ⏭</b> (Press and hold)	Fast-forward/Fast-reverse
<b>▶ ⏸</b>	Playback / Pause

## Convenient functions

Here, we explain how to use convenient functions for NETWORK sources and USB sources. The source names under the titles of each function's description are sources that allow use of these functions.

❑ **Searching content with keywords (Text Search)** (👉 [page 63](#))

❑ **Performing repeat playback (Repeat)** (👉 [page 63](#))

❑ **Performing random playback (Random)** (👉 [page 64](#))

❑ **Favorites function** (👉 [page 65](#))

❑ **Playing back music and a favorite picture at the same time (Slideshow)** (👉 [page 66](#))

❑ **Playing back still images in sequential order (Slideshow Interval)** (👉 [page 66](#))

❑ **Adjusting the picture quality for your viewing environment (Picture Mode)** (👉 [page 67](#))

❑ **All Zone Stereo function** (👉 [page 68](#))

## Searching content with keywords (Text Search)

USB Internet Radio Media Server

**1** While content is playing, press **OPTION**.  
The option menu screen is displayed.

**2** Use  $\Delta$ / $\nabla$  to select "Text Search", then press **ENTER**.  
The keyboard input screen is displayed.

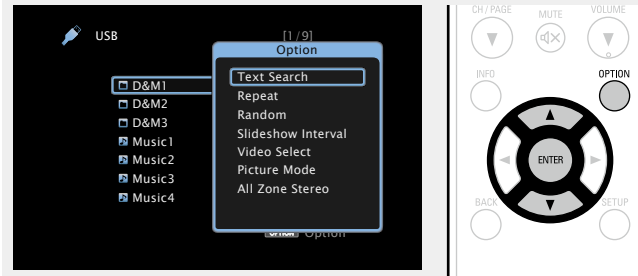

**3** Enter the first character of the Internet Radio station or file you want to search for, and then press **OK**.

• For character input, see [page 99](#).



"Text Search" searches for Internet Radio stations or files that start with the entered first character from the displayed list.

### NOTE

"Text Search" may not work for some lists.

### ❑ Playing back a search result content

Use  $\Delta$ / $\nabla$  to select the content you want to play, and then press **ENTER** or  $\triangleright$ .

Playback starts.



## Performing repeat playback (Repeat)

USB Media Server Spotify

**1** While content is playing, press **OPTION**.  
The option menu screen is displayed.

**2** Use  $\Delta$ / $\nabla$  to select "Repeat", then press **ENTER**.

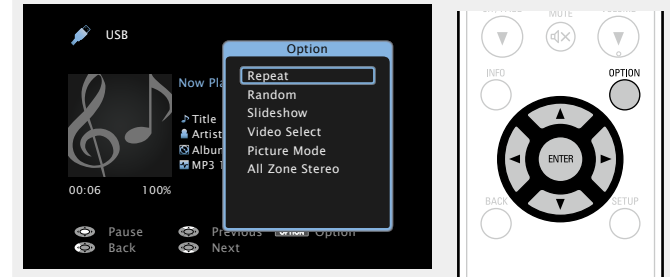

**3** Use  $\triangleleft$ / $\triangleright$  to select repeat playback mode.

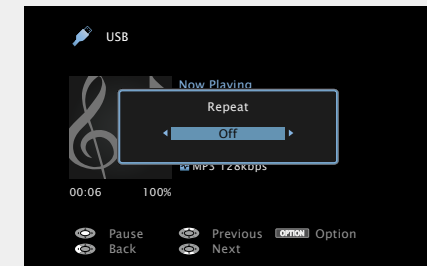

• Each time  $\triangleleft$ / $\triangleright$  is pressed, the setting is changed as shown below.



**Off** Repeat playback mode is canceled.

**One** A file being played is played repeatedly.

**All** All files in the folder currently being played are played repeatedly.

**4** Press **ENTER**.  
The display returns to the playback screen.

## Performing random playback (Random)

USB Media Server Spotify

**1** While content is playing, press **OPTION**.  
The option menu screen is displayed.

**2** Use  $\Delta$ / $\nabla$  to select “Random”, then press **ENTER**.

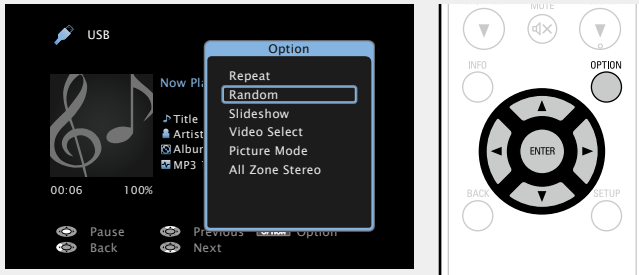

**3** Use  $\triangleleft$ / $\triangleright$  to select random playback mode.

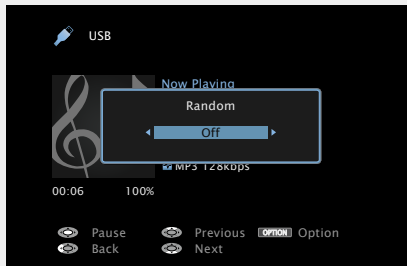

• Each time  $\triangleleft$ / $\triangleright$  is pressed, the setting is changed as shown below.

Off  $\longleftrightarrow$  On

**Off** Disable random playback.

**On** Randomly play back all tracks in the current playback folder.

**4** Press **ENTER**.  
The display returns to the playback screen.



During random playback, each time playback of a track is completed, another track is randomly selected for playback from tracks in the folder. Therefore, it's possible that you may hear a track played back more than once during random playback.

## Favorites function

There are two ways to add content to favorites:

- ① Add to favorites from the Option menu
- ② Add to the **FAVORITE STATION** button

### ❑ Add to favorites from the Option menu (Save to Favorites)

**Internet Radio** **Media Server**

You can add up to 100 items as favorites for all sources (Internet Radio and Media Server).

#### 1 While content is playing, press **OPTION**.

The option menu screen is displayed.

#### 2 Use $\Delta \nabla$ to select “Save to Favorites”, then press **ENTER**.

“Favorite added” is displayed, and the current content is added to favorites.

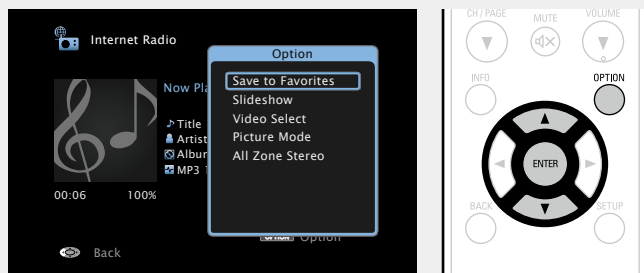

- The display returns to the playback screen when the procedure is completed.

## Playing back content added in “Save to Favorites”

#### 1 Press **NETWORK**.

#### 2 Use $\Delta \nabla \triangleleft \triangleright$ to select “Favorites”, then press **ENTER**.

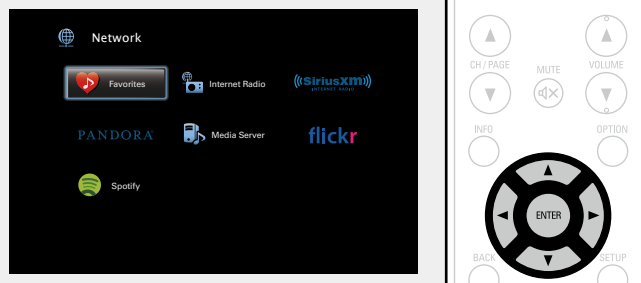

#### 3 Use $\Delta \nabla$ to select the content you want to play, and then press **ENTER** or $\triangleright$ . Playback starts.

### ❑ Adding to the FAVORITE STATION button

You can add up to three types of content.

#### NOTE

- Please note that if you add new content to a number that already contains content, the older content is deleted.
- The following operations update the database on the Media Server, which may make the added music files unplayable.
  - When you quit the Media Server and then restart it.
  - When music files are deleted or added on the Media Server.
- When using an ESCIENT server, place “ESCIENT” before the server name.

### Press and hold one of the FAVORITE STATION 1 – 3 buttons for 3 seconds or longer while playing back a content or listening to a radio station.

The content you are playing back or the radio station you are listening to is registered to the pressed button.

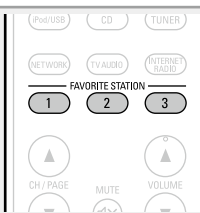

Contents that can be added to the **FAVORITE STATION** button differ depending on the input source.

Input source	Contents that can be added
<b>TUNER</b>	Radio station
<b>Internet Radio</b>	Top list of content / Internet Radio station
<b>Media Server</b>	Top list of content / Track
<b>Flickr</b>	Top list of content
<b>Pandora</b>	Top list of content
<b>SiriusXM</b>	Top list of content
<b>Spotify</b>	Top list of content
<b>Favorites</b>	Top list of content / Internet Radio station / Track of Media Server

## Playing back content added to the FAVORITE STATION button

You can easily call up content by pressing the **FAVORITE STATION** button.

### Press one of the FAVORITE STATION 1 – 3 buttons that you added content to. Playback starts.

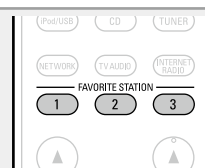

Internet Radio stations are already registered to the **FAVORITE STATION 1 – 3** buttons. However, you may not be able to play the stations due to restrictions imposed by the radio stations.



## ❑ Deleting content added to favorites (Remove from Favorites)

**1** Press **NETWORK**.

**2** Use  $\Delta \nabla \triangleleft \triangleright$  to select **“Favorites”**, then press **ENTER**.

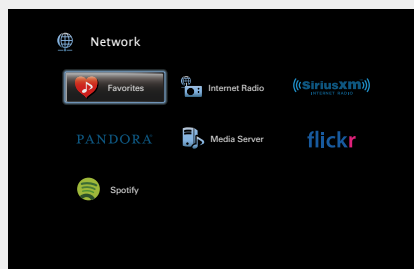

**3** Use  $\Delta \nabla$  to select the content you want to delete from favorites, then press **OPTION**.  
The option menu screen is displayed.

**4** Use  $\Delta \nabla$  to select **“Remove from Favorites”**, then press **ENTER**.  
“Favorite removed” is displayed, and the selected content is deleted from favorites.

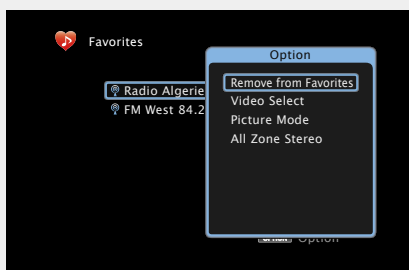

• The display returns to the original screen when the procedure is completed.

## Playing back music and a favorite picture at the same time (Slideshow)

**USB** **Internet Radio** **Media Server**

**1** Play back a still picture.

- Playing back still pictures stored on USB memory devices (☞ [page 34](#)).
- Playing back still pictures stored on Flickr (☞ [page 53](#)).

**2** Play back a music file or Internet Radio station (☞ [page 45, 50](#)).

**3** Press **OPTION**.  
The option menu screen is displayed.

**4** Use  $\Delta \nabla$  to select **“Slideshow”**, then press **ENTER**.  
The option menu disappears, and the picture you were viewing is shown on the screen.

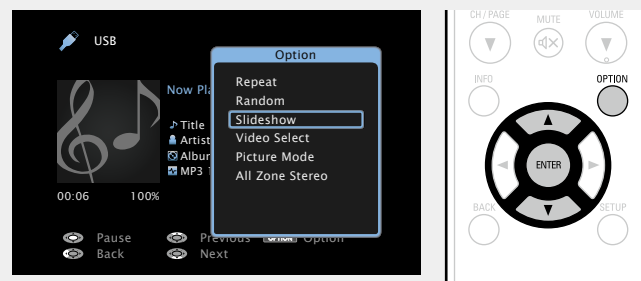

## Playing back still images in sequential order (Slideshow Interval)

You can play back still image (JPEG) files stored on a USB memory device or Media Server and pictures on Flickr website as a slide show. The display time can also be set.

**USB** **Media Server** **Flickr**

**1** Play back an image and press **OPTION**.  
The option menu screen is displayed.

**2** Use  $\Delta \nabla$  to select **“Slideshow Interval”**, then press **ENTER**.

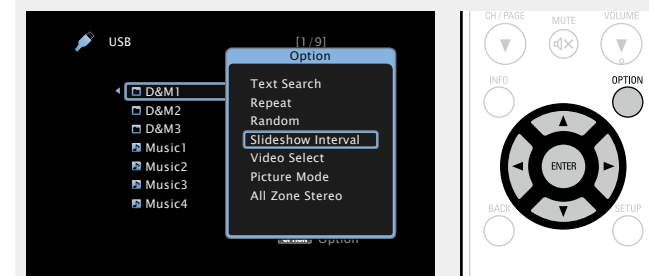

**3** Use  $\triangleleft \triangleright$  to set the display time.

- Each time  $\triangleleft \triangleright$  is pressed, the setting is changed as shown below.

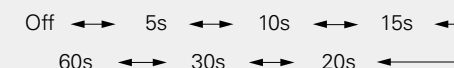

**Off** The slide show is not played back.

**5s – 60s** Set the time for displaying a single image when playing back images in the slide show.

**4** Press **ENTER**.  
The slide show is displayed on the screen.



This unit plays back image (JPEG) files in the orientation in which they are stored in the folder.

## Displaying your desired video on the monitor during audio playback (Video Select)

This unit can display video from a different source on TV during audio playback.

You can set this for each input source.

**USB** **CD** \* **TUNER** **NETWORK**

\* Available when none of HDMI, component video or video connector is assigned.

### 1 Press **OPTION** during audio playback.

The option menu screen is displayed.

### 2 Use $\Delta$ / $\nabla$ to select "Video Select", then press **ENTER**.

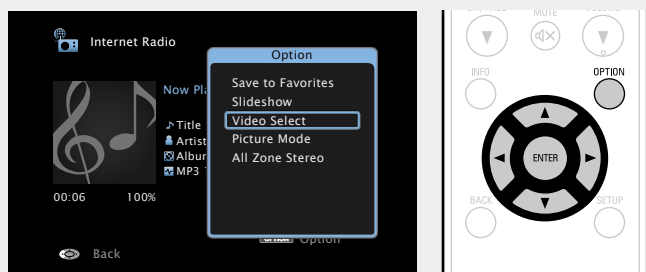

### 3 Use $\triangleleft$ / $\triangleright$ to select the Video Select mode.

• Each time  $\triangleleft$ / $\triangleright$  is pressed, the setting is changed as shown below.

Off  $\longleftrightarrow$  On

**Off** Disable Video Select mode.

**On** Enable Video Select mode.

### 4 If you selected "On" in step 3, press $\nabla$ and select "Source".

### 5 Press $\triangleleft$ / $\triangleright$ to select the input source for video you want to play back, and press **ENTER**.

Playback starts.

#### NOTE

Input sources for which "Hide" is selected at "Hide Sources" (page 114) cannot be selected.

## Adjusting the picture quality for your viewing environment (Picture Mode)

**CBL/SAT** **DVD** **Blu-ray** **GAME** **AUX** **MEDIA PLAYER** **USB**

**Internet Radio** **Media Server** **CD** \* **TV AUDIO** \*

\* You can set the picture mode when an HDMI, component video or video connector is assigned.

### 1 While content is playing, press **OPTION**.

The option menu screen is displayed.

### 2 Use $\Delta$ / $\nabla$ to select "Picture Mode", then press **ENTER**.

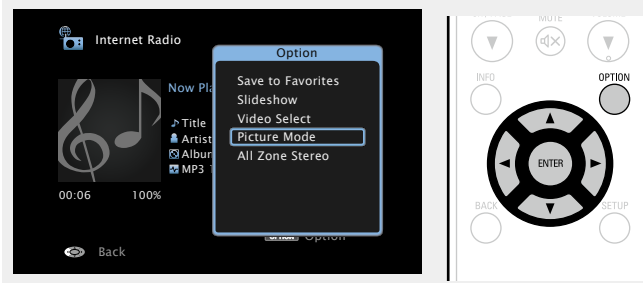

### 3 Use $\triangleleft$ / $\triangleright$ to select picture mode.

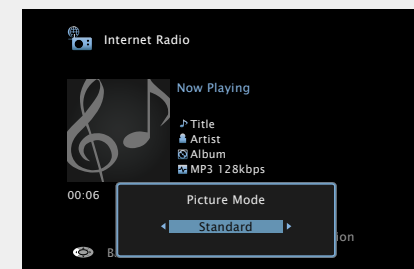

• Each time  $\triangleleft$ / $\triangleright$  is pressed, the setting is changed as shown below.

Off  $\longleftrightarrow$  Standard  $\longleftrightarrow$  Movie  $\longleftrightarrow$  Vivid  
 Custom  $\longleftrightarrow$  Streaming  $\longleftrightarrow$  Vivid

**Off** No picture quality adjustment is done with this unit.

**Standard** The standard mode suited for most living room viewing environments.

**Movie** A mode suited for watching movies in a dark room such as a theater room.

**Vivid** A mode that makes graphic images for games, etc. brighter and more vivid.

**Streaming** A mode suited for low bit rate video sources.

**Custom** Adjusts the picture quality manually.

### 4 Press **ENTER**.

The display returns to the playback screen.

## All Zone Stereo function

You can play back music in multi-zones (ZONE2) simultaneously that is played back in MAIN ZONE.

It is useful when you want to enjoy the same music at the same time in multiple rooms during home party or when you want to play back the same BGM in the entire house.

The All Zone Stereo function can be set for any source.



Before setting this function, you need to turn on the multi-zones (ZONE2) for which you want to use the All Zone Stereo function.

**1 Press MAIN to switch the zone mode.**  
MAIN lights.

**2 Press OPTION.**  
The option menu screen is displayed.

**3 Use  $\Delta$ / $\nabla$  to select “All Zone Stereo”, then press ENTER.**

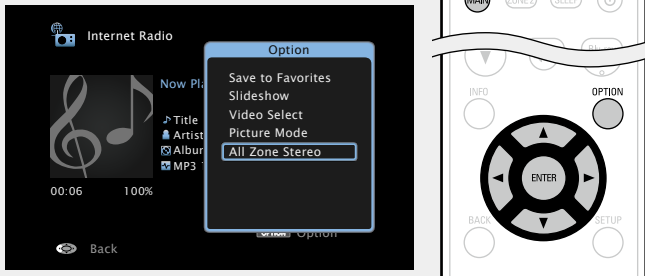

**4 Use  $\triangleleft$ / $\triangleright$  to select “On”, then press ENTER.**  
The input source for the multi-zones (ZONE2) is switched to the same as the one for MAIN ZONE, and playback in the All Zone Stereo mode starts.

## Stopping the All Zone Stereo function

**1 During playback in All Zone Stereo, press OPTION.**  
The option menu screen is displayed.

**2 Use  $\Delta$ / $\nabla$  to select “All Zone Stereo”, then press ENTER.**

**3 Use  $\triangleleft$ / $\triangleright$  to select “Off”, then press ENTER.**

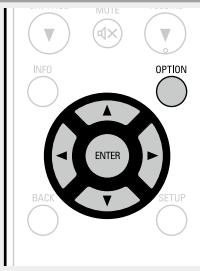

The All Zone Stereo function is also stopped when you:

- Turn MAIN ZONE off.
- Change the input source for MAIN ZONE.
- Change the sound mode.

### NOTE

When “HDMI Audio Out” ([page 107](#)) is set to “TV”, the All Zone Stereo function is not available.

## AirPlay function

Enjoy music from your iTunes library with high quality sound anywhere in your home.

Use the Apple Remote App\* for iPhone, iPod touch and iPad to control iTunes from any room in your home.

\* Available as a free download from the App Store.

### Streaming music stored in iPhone, iPod touch, or iPad directly to the unit

If you update your "iPhone/iPod touch/iPad" to iOS 4.2.1 or later, you can stream music stored in your "iPhone/iPod touch/iPad" directly to this unit.

#### 1 Make the Wi-Fi settings for iPhone, iPod touch, or iPad.

• For details, see your device's manual.

#### 2 Startup iPhone, iPod touch, or iPad music or iPod app.

 is displayed on the iPhone, iPod touch or iPad screen.

#### 3 Tap the AirPlay icon .

#### 4 Select the speaker you want to use.

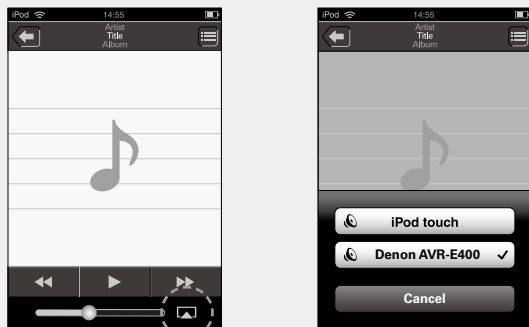

#### NOTE

In playback using the AirPlay function, the sound is output at the iPhone, iPod touch, iPad or iTunes volume setting level.

You should turn down the iPhone, iPod touch, iPad or iTunes volume prior to playback and then adjust it to a suitable level.

### Playing iTunes music with this unit

#### 1 Install iTunes 10, or later, on a Mac or Windows PC that is connected to the same network as this unit.

#### 2 Turn this unit ON.

Set "IP Control" ([see page 120](#)) to "Always On" for this unit.

#### NOTE

When "IP Control" is set to "Always On", the unit consumes more standby power.

#### 3 Launch iTunes and click the AirPlay icon displayed the window and select this unit from the list.



#### 4 Choose a song and click play in iTunes.

The music will stream to this unit.

### Selecting multiple speakers (devices)

It is possible to play iTunes songs on your home's AirPlay compatible speakers (devices) other than those of this unit.

#### 1 Click the AirPlay icon and select "Multiple".

#### 2 Check the speakers you want to use.

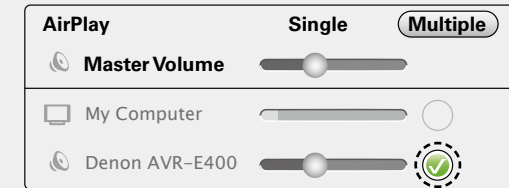

## □ Perform iTunes playback operations with the remote control unit of this unit

With this unit's remote control unit, you can perform iTunes song play, pause, and auto search (cue) operations.

**1** Select “Edit” – “Preferences...” on the menu.

**2** Select “Devices” in the iTunes setting window.

**3** Check “Allow iTunes audio control from remote speakers”, and then click “OK”.

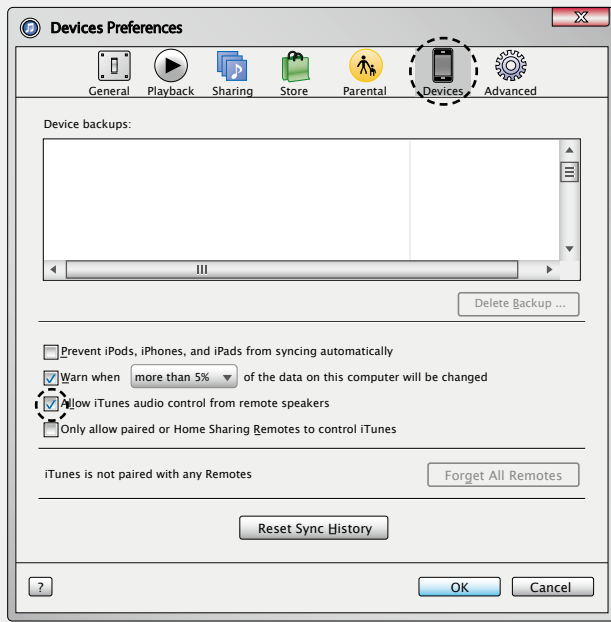

-  is displayed on the menu screen while AirPlay is being operated.
- Source input will be switched to “NETWORK” when AirPlay playback is started.
- You can stop AirPlay playback by pressing the ◀ or choosing other input source.
- To see song and artist names together, press **STATUS** on the main unit.
- For information about how to use iTunes, also see the Help for iTunes.
- The screen may differ depending on the OS and software versions.

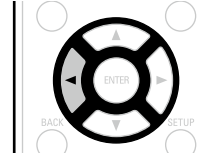

# Selecting a listening mode (Sound Mode)

This unit allows you to enjoy various kinds of surround and stereo playback modes.

Multi-channel audio formats are provided on popular movie and music disc formats such as Blu-ray and DVD, as well as being supported by digital broadcasting, and even by streaming movies and music from internet-based subscription services.

This unit supports playback of almost all of these multi-channel audio formats. It also supports surround playback of audio formats other than multi-channel audio such as 2-channel stereo audio.

This unit automatically generates a list of all the playable sound modes based on the input audio format and the current speaker setup configuration and displays the list on the screen. Therefore, you can select a correct surround playback mode even if you are not familiar with sound mode selection. Try out various surround playback modes and enjoy surround playback in your favorite mode.

**[Example]** When **MOVIE** is pressed and held



This unit provides not only sound modes that conform to the formats recorded on discs such as Dolby and DTS but also extended types of modes that match your speaker configuration including front height speakers and surround back speakers and “original listening modes” that create atmosphere of ROCK ARENA and JAZZ CLUB, etc.

The displayed sound modes include the 2-channel stereo playback mode with no additional surround sound synthesis.



For audio formats recorded on a disc, see the disc jacket or label.

## Selecting a listening mode

### 1 Play the selected device (page 29 – 61).

### 2 Press and hold **MOVIE**, **MUSIC** or **GAME** to select a listening mode.

This unit automatically generates and displays a list of selectable sound modes.

- Each time **MOVIE**, **MUSIC** or **GAME** is pressed, the listening mode is switched.

**MOVIE** Switches to the listening mode suitable for enjoying movies and TV programs.

**MUSIC** Switches to the listening mode suitable for enjoying music.

**GAME** Switches to the listening mode suitable for enjoying games.

- Pressing **MOVIE**, **MUSIC** or **GAME** displays a list of the listening modes that can be selected. Each time you press **MOVIE**, **MUSIC** or **GAME**, the listening mode changes.
- While the list is displayed, you can also use  $\Delta$ / $\nabla$  to select a listening mode.

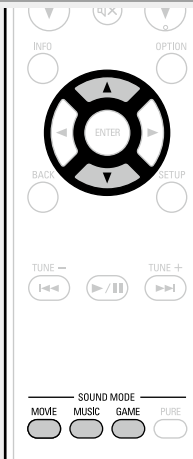

- The **MOVIE**, **MUSIC**, or **GAME** button memorizes the last sound mode selected for its button. Pressing **MOVIE**, **MUSIC**, or **GAME** recalls the same sound mode as the one selected at the previous playback.
- If the content played back does not support the previously selected sound mode, the most appropriate sound mode for the content is automatically selected.

## Direct playback

Sound recorded in source is played as is.

### 1 Play the selected device (page 29 – 61).

### 2 Press **PURE** to select “DIRECT”.

Direct playback begins.

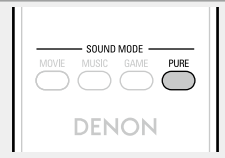

## Pure Direct playback

This mode is for playback with higher sound quality than in “DIRECT” mode, by turning off the front panel display panel, which can eliminate faint low level noise from creeping into sensitive analog circuitry.

### 1 Play the selected device (page 29 – 61).

### 2 Press **PURE** to select “PURE DIRECT”.

The display goes dark, and pure direct playback begins.

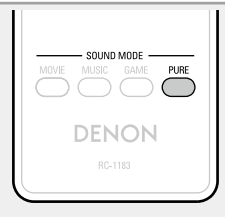

In DIRECT and PURE DIRECT listening modes, the following items cannot be adjusted.

- Tone (page 103)
- Restorer (page 103)
- MultEQ® (page 104)
- Dynamic EQ (page 105)
- Dynamic Volume (page 105)

### NOTE

- Video signals are only output when HDMI signals are played in the PURE DIRECT mode.
- When in the PURE DIRECT mode, the menu screen is not displayed.
- When in the PURE DIRECT mode, the display turns off and appears as if there is no electricity.

## Listening mode

- The following listening modes can be selected using the **MOVIE**, **MUSIC**, **GAME**, and **PURE** buttons.
- Adjust the sound field effect with the menu "Surround Parameter" ([page 101](#)) to enjoy surround sound the way you like it.

Operation button	Input signal	Listening mode
MOVIE	2-channel *1	STEREO
		DOLBY PLIIx Cinema *2
		DOLBY PLII Cinema *2
		DOLBY PLIIz Height *2
		DTS NEO:6 Cinema *2
		MULTI CH STEREO
		MONO MOVIE
	Multi-channel *3	STEREO
	Dolby Digital	DOLBY DIGITAL
		DOLBY DIGITAL EX
		DOLBY DIGITAL + PLIIx Cinema
	Dolby TrueHD	DOLBY DIGITAL + PLIIz
		DOLBY TrueHD
		DOLBY TrueHD + EX
	Dolby Digital Plus	DOLBY TrueHD + PLIIx Cinema
		DOLBY TrueHD + PLIIz
		DOLBY DIGITAL Plus
	Dolby Digital Plus	DOLBY DIGITAL Plus + EX
		DOLBY DIGITAL Plus + PLIIx Cinema
		DOLBY DIGITAL Plus + PLIIz
	DTS	DTS SURROUND
		DTS ES DSCRT 6.1
		DTS ES MTRX 6.1
		DTS 96/24
		DTS + PLIIx Cinema
	DTS-HD / DTS Express	DTS + PLIIz
		DTS + NEO:6
DTS-HD HI RES		
DTS-HD MSTR		
DTS Express		
PCM multi-channel	DTS-HD + PLIIx Cinema	
	DTS-HD + PLIIz	
	DTS-HD + NEO:6	
	MULTI CH IN	
	MULTI CH IN 7.1	
	MULTI IN + Dolby EX	
	MULTI IN + PLIIx Cinema	
	MULTI IN + PLIIz	
	MULTI CH STEREO	
	MONO MOVIE	
	VIRTUAL	

Operation button	Input signal	Listening mode	
MUSIC	2-channel *1	STEREO	
		DOLBY PLIIx Music *2	
		DOLBY PLII Music *2	
		DOLBY PLIIz Height *2	
		DTS NEO:6 Music *2	
		MULTI CH STEREO	
		ROCK ARENA	
		JAZZ CLUB	
		MATRIX	
		VIRTUAL	
		Multi-channel *3	STEREO
			Dolby Digital
	DOLBY DIGITAL EX		
	DOLBY DIGITAL + PLIIx Music		
	Dolby TrueHD		DOLBY DIGITAL + PLIIz
			DOLBY TrueHD
			DOLBY TrueHD + EX
	Dolby Digital Plus		DOLBY TrueHD + PLIIx Music
			DOLBY TrueHD + PLIIz
			DOLBY DIGITAL Plus
	Dolby Digital Plus		DOLBY DIGITAL Plus + EX
			DOLBY DIGITAL Plus + PLIIx Music
			DOLBY DIGITAL Plus + PLIIz
	DTS		DTS SURROUND
		DTS ES DSCRT 6.1	
		DTS ES MTRX 6.1	
		DTS 96/24	
DTS + PLIIx Music			
DTS-HD / DTS Express	DTS + PLIIz		
	DTS + NEO:6		
	DTS-HD HI RES		
	DTS-HD MSTR		
	DTS Express		
	DTS-HD + PLIIx Music		
	DTS-HD + PLIIz		
	DTS-HD + NEO:6		

Operation button	Input signal	Listening mode
MUSIC	PCM multi-channel	MULTI CH IN
		MULTI CH IN 7.1
		MULTI IN + Dolby EX
		MULTI IN + PLIIx Music
		MULTI IN + PLIIz
	Multi-channel *3	MULTI CH STEREO
		ROCK ARENA
		JAZZ CLUB
		MATRIX
		VIRTUAL

\*1 2-channel also includes analog input.

\*2 This mode plays back 2-channel sources in 5.1 or 7.1-channel playback. It cannot be selected when headphones are used, or when only front speakers are used.

\*3 Some listening modes cannot be selected, depending on the audio format or number of channels of the input signal. For details, see "Types of input signals, and corresponding sound modes" ([page 138](#)).

Operation button	Input signal	Listening mode	
GAME	2-channel *1	STEREO	
		DOLBY PLIIx Game *2	
		DOLBY PLII Game *2	
		DOLBY PLIIz Height *2	
		MULTI CH STEREO	
		VIDEO GAME	
	Multi-channel *3	Dolby Digital	STEREO
			DOLBY DIGITAL
			DOLBY DIGITAL EX
		Dolby TrueHD	DOLBY DIGITAL + PLIIz
			DOLBY TrueHD
			DOLBY TrueHD + EX
		Dolby Digital Plus	DOLBY TrueHD + PLIIz
			DOLBY DIGITAL Plus
			DOLBY DIGITAL Plus + EX
		DTS	DOLBY DIGITAL Plus + PLIIz
			DTS SURROUND
			DTS ES DSCRT 6.1
			DTS ES MTRX 6.1
			DTS 96/24
			DTS + PLIIz
		DTS-HD / DTS Express	DTS + NEO:6
			DTS-HD HI RES
			DTS-HD MSTR
DTS Express			
DTS-HD + PLIIz			
PCM multi-channel	DTS-HD + NEO:6		
	MULTI CH IN		
	MULTI CH IN 7.1		
	MULTI IN + Dolby EX		
	MULTI IN + PLIIz		
	MULTI CH STEREO		
PURE	All	VIDEO GAME	
		VIRTUAL	
		PURE DIRECT	
		DIRECT	

- \*1 2-channel also includes analog input.
- \*2 This mode plays back 2-channel sources in 5.1 or 7.1-channel playback. It cannot be selected when headphones are used, or when only front speakers are used.
- \*3 Some listening modes cannot be selected, depending on the audio format or number of channels of the input signal. For details, see "Types of input signals, and corresponding sound modes" (page 138).

### Views on the TV screen or display

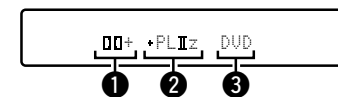

- 1 Shows a decoder to be used.
  - A DOLBY DIGITAL Plus decoder is displayed as "Dolby+".
- 2 Shows a decoder that creates sound output from the surround back speakers.
  - "+ PLIIz" indicates the front height sound from front height speakers.
- 3 Shows the name of the input source being played back.



## □ Description of listening mode types

### Dolby listening mode

Listening mode type	Description
DOLBY PLIIx*1	This mode can be selected when the Dolby Pro Logic IIx decoder is used to play back 2-channel sources in 6.1/7.1-channel surround sound including the surround back channel(s). By adding the surround back channel(s), a more enveloping surround environment is produced, compared to Dolby Pro Logic II. There are three playback modes: "Cinema" mode that is optimized for movie playback, "Music" mode that is optimized for music playback, and "Game" mode that is optimized for game play.
DOLBY PLII	This mode can be selected when the Dolby Pro Logic II decoder is used to play back 2-channel sources in 5.1-channel surround sound with an enveloping surround sound experience.
DOLBY PLIIz*2	This mode can be selected when the Dolby Pro Logic IIz decoder is used to play back 2-channel sources in 7.1-channel surround sound with added front height channels. By adding front height channels, the front soundstage becomes dramatically taller, simulating the effect of listening in a large movie theater or concert hall.
DOLBY DIGITAL	This mode can be selected when playing sources recorded with Dolby Digital.
DOLBY DIGITAL EX*1	Using the Dolby Digital EX decoder, this mode plays Dolby Digital sources in 6.1/7.1 channel surround sound with added surround back channel(s). By adding surround back channel(s), sounds can be heard coming at you from behind and not just from the sides.
DOLBY TrueHD	This mode can be selected when playing sources recorded in Dolby TrueHD.
DOLBY DIGITAL Plus	This mode can be selected when playing sources recorded with Dolby Digital Plus.

\*1 This can be selected when "Speaker Config." – "Surr. Back" ([page 116](#)) is not set to "None".

\*2 This can be selected when "Speaker Config." – "Front Height" ([page 116](#)) is not set to "None".

### DTS listening mode

Listening mode type	Description
DTS NEO:6	This mode can be selected when a DTS NEO:6 decoder is used to play back 2-channel source in 6.1/7.1-channel surround sound including the surround back channel. There is a "Cinema" mode optimized for movie playback, and a "Music" mode optimized for music playback.
DTS SURROUND	This mode can be selected when playing sources recorded in DTS.
DTS ES DSCRT6.1*1	This mode is suitable for playing discs recorded in DTS-ES. The surround back channel added using the discrete method is played as an independent channel. Since all channels are independent, the 360-degree spacial expressiveness and sound localization are enhanced.
DTS ES MTRX6.1*2	This mode is suitable for playing discs recorded in DTS-ES. The surround back channel added to the surround-left and surround-right channels by a matrix encoder at software recording time is decoded by this unit's matrix decoder and played from each channel (surround left, surround right, surround back).
DTS 96/24	This mode can be selected when playing sources recorded in DTS 96/24.
DTS-HD	This mode can be selected when playing sources recorded in DTS-HD.
DTS Express	This mode can be selected when playing sources recorded in DTS Express.

\*1 This mode can be selected when only one surround back speaker is used and no front height speaker is used.

\*2 This can be selected when "Speaker Config." – "Surr. Back" ([page 116](#)) is not set to "None".

### PCM multi-channel listening mode

Listening mode type	Description
MULTI CH IN	This mode can be selected when playing multi-channel PCM sources from a disc player or external decoder that features analog multi-channel outputs .

**Original listening mode**

Listening mode type	Description
MULTI CH STEREO	This mode is for enjoying stereo sound from all speakers. Stereo audio (2 channel) sources are played back via the front (L/R) speakers, the surround speakers and if connected the surround back speakers.
ROCK ARENA	This mode simulates the expansive sound of a live concert in an arena.
JAZZ CLUB	This mode puts you right in the middle of an intimate jazz club.
MONO MOVIE	This mode works with monaural audio sources and delivers a surround sound effect. For optimum channel balance and surround sound effects, connect the monaural source to both of the front (L/R) audio inputs.
VIDEO GAME	This mode provides an exciting, dynamic surround sound effect with your favorite action video games.
MATRIX	This mode adds a spacious surround sound effect with stereo music sources.
VIRTUAL	This mode lets you experience an expansive surround sound effect when playing back through just the front (L/R) speakers only, and when listening with stereo headphones.

**STEREO listening mode**

Listening mode type	Description
STEREO	This mode plays 2-channel stereo audio with no additional surround sound processing. <ul style="list-style-type: none"> <li>• Sound is output from the front left and right speakers, and subwoofer if connected.</li> <li>• When multi-channel signals are inputted, they are mixed down to 2-channel audio and are played back with no additional surround sound processing.</li> </ul>





**Direct listening mode**

Listening mode type	Description
DIRECT	This mode provides a direct input-to-output path with minimal audio processing, bypassing any unnecessary stages for purest sound.
PURE DIRECT	This mode provides the direct audio signal path benefit of the Direct mode along with disabling additional stages that might possibly have an affect on sound quality. In Pure Direct mode, the following elements are turned off: <ul style="list-style-type: none"> <li>• The front panel display and its driver circuitry are shut down.</li> <li>• The analog video input/output switcher and processor is disabled.</li> </ul>

## Advanced instructions

---

Here we explain functions and operations in more detail so that you can maximize your enjoyment with this unit.

- **Installation/connection/setup of speakers (Advanced)**  [page 77](#)
- **Playback (Advanced operation)**  [page 88](#)
- **Playback in ZONE2 (Separate room)**  [page 93](#)
- **How to make detailed settings**  [page 95](#)

# Installation/connection/setup of speakers (Advanced)

## Procedure for speaker settings

Speaker installation



Speaker connection (page 79)



Set up speakers (page 86)

## Speaker installation

- Determine the speaker system depending on the number of speakers you are using and install each speaker and subwoofer in the room. Here, we explain how to install the speakers using a typical example.
- The speaker impedance should be from 6 to 16 Ω/ohms.

This unit is compatible with Dolby Pro Logic IIz (page 142) and DTS Neo:6 (page 143) which offers an even wider and deeper surround sensation. When using Dolby Pro Logic IIz, install front height speakers.



Use the illustration below as a guide for how high each speaker should be installed. The height does not need to be exactly the same.

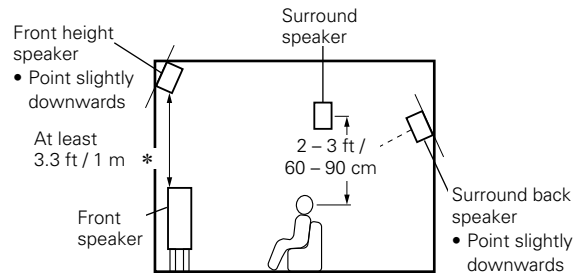

[Viewed from the side]

\* Recommended for Dolby Pro Logic IIz

## When 7.1-channel speakers are installed using surround back speakers

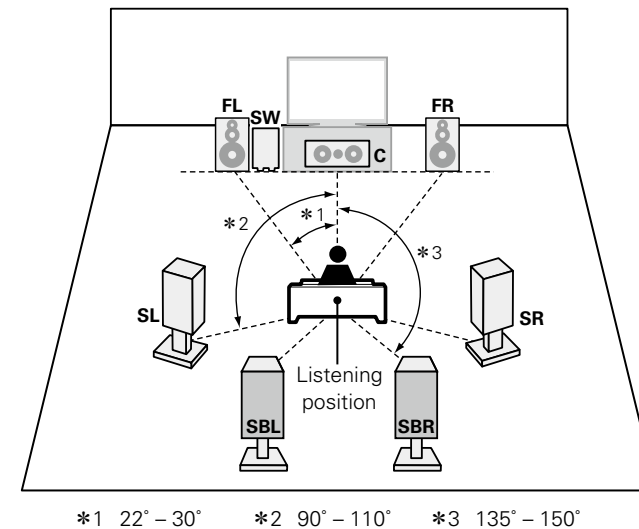

### NOTE

You cannot have audio output from the surround back speakers and front height speakers simultaneously.

### [Speaker abbreviations]

- |                             |                                      |
|-----------------------------|--------------------------------------|
| <b>FL</b> Front speaker (L) | <b>SL</b> Surround speaker (L)       |
| <b>FR</b> Front speaker (R) | <b>SR</b> Surround speaker (R)       |
| <b>C</b> Center speaker     | <b>SBL</b> Surround back speaker (L) |
| <b>SW</b> Subwoofer         | <b>SBR</b> Surround back speaker (R) |

### When 7.1-channel speakers are installed using front height speakers

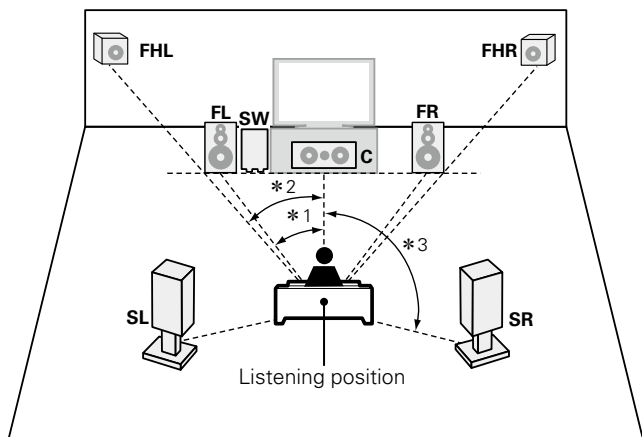

\*1 22° - 30°   \*2 22° - 45°   \*3 90° - 110°

### When 6.1-channel speakers are installed

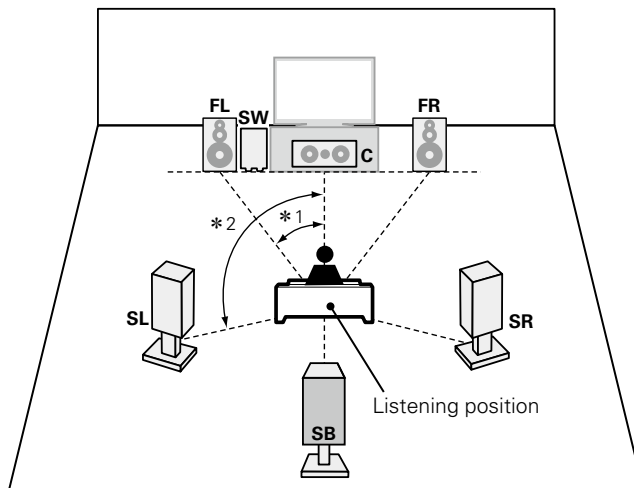

\*1 22° - 30°   \*2 90° - 110°

### When 5.1-channel speakers are installed

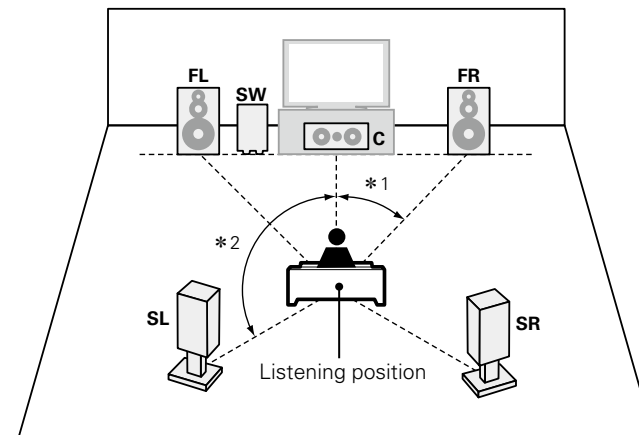

\*1 22° - 30°   \*2 120°

**[Speaker abbreviations]**

- |                             |                                     |
|-----------------------------|-------------------------------------|
| <b>FL</b> Front speaker (L) | <b>SL</b> Surround speaker (L)      |
| <b>FR</b> Front speaker (R) | <b>SR</b> Surround speaker (R)      |
| <b>C</b> Center speaker     | <b>SB</b> Surround back speaker     |
| <b>SW</b> Subwoofer         | <b>FHL</b> Front height speaker (L) |
|                             | <b>FHR</b> Front height speaker (R) |

# Speaker connection

Here we connect the speakers in the room to this unit.  
This section explains how to connect them using typical examples.

- ❑ **Connecting 7.1-channel speakers using surround back speakers** (👉 [page 81](#))
- ❑ **Connecting 7.1-channel speakers using front height speakers** (👉 [page 82](#))
- ❑ **Connecting 6.1-channel speakers using one surround back speaker** (👉 [page 83](#))
- ❑ **Connecting 5.1-channel speakers** (👉 [page 84](#))
- ❑ **Connecting 2.1-channel speakers** (👉 [page 85](#))

## NOTE

- Disconnect this unit's power plug from the power outlet before connecting the speakers. Also, turn off the subwoofer.
- Connect so that the speaker cable core wires do not protrude from the speaker terminal. The protection circuit may be activated if the core wires touch the rear panel or if the + and - sides touch each other (👉 [page 143](#) "Protection Circuit").
- Never touch the speaker terminals while the power cord is connected. Doing so could result in electric shock. When the "Setup Assistant" is running, follow the instructions in the "Setup Assistant" screen for making connections. (Power is not supplied to the speaker terminals while the "Setup Assistant" is running.)
- Use speakers with the speaker impedances shown below.

Speaker terminals	Speaker impedance
FRONT	6 – 16 Ω/ohms
CENTER	
SURROUND	
SURROUND BACK	

## Connecting the speaker cables

Carefully check the left (L) and right (R) channels and + (red) and - (black) polarities on the speakers being connected to this unit, and be sure to connect the channels and polarities correctly.

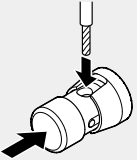
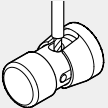
- 1** Peel off about 3/8 inch (10 mm) of sheathing from the tip of the speaker cable, then either twist the core wire tightly or terminate it.
 
- 2** Press the speaker terminal to show the terminal hole.
 
- 3** Release your finger from the speaker terminal to fix the speaker cable.
 

## Cables used for connections

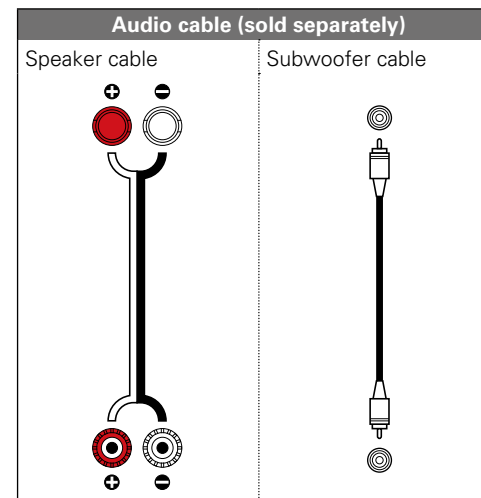

## Connecting the subwoofer

Use a subwoofer cable to connect the subwoofer.

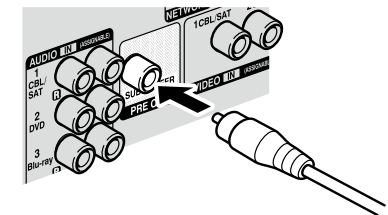

**□ About the speaker cable label (supplied) for channel identification**

The channel display section for speaker terminals on the rear panel is color-coded for each channel to be identifiable.

Speaker terminals	Color
FRONT L	White
FRONT R	Red
CENTER	Green
SURROUND L	Light blue
SURROUND R	Blue
SURROUND BACK L	Beige
SURROUND BACK R	Brown

Attach the speaker cable label for each channel to its speaker cable as shown in the diagram. Then, make connection so that the color of the speaker terminal matches that of the speaker cable label.

**[How to attach the speaker cable label]**

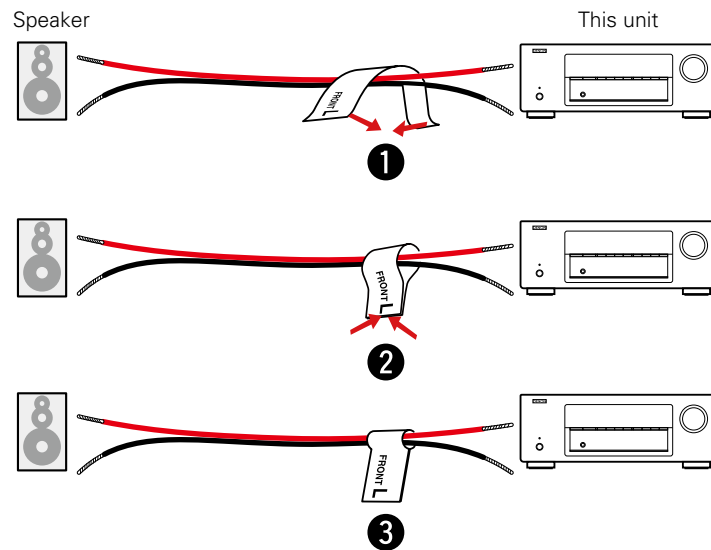

## Connecting 7.1-channel speakers using surround back speakers

The illustration on the right shows a connection example for performing 7.1-channel playback using the surround back speakers.

To perform 7.1-channel playback using the surround back speakers, set "Assign Mode" to "Surround Back" in steps 3 to 5 for "Set up "Amp Assign"" ([page 86](#)).

**NOTE**

- For speaker cable connections, see [page 79](#).
- For speaker impedance, see [page 79](#).

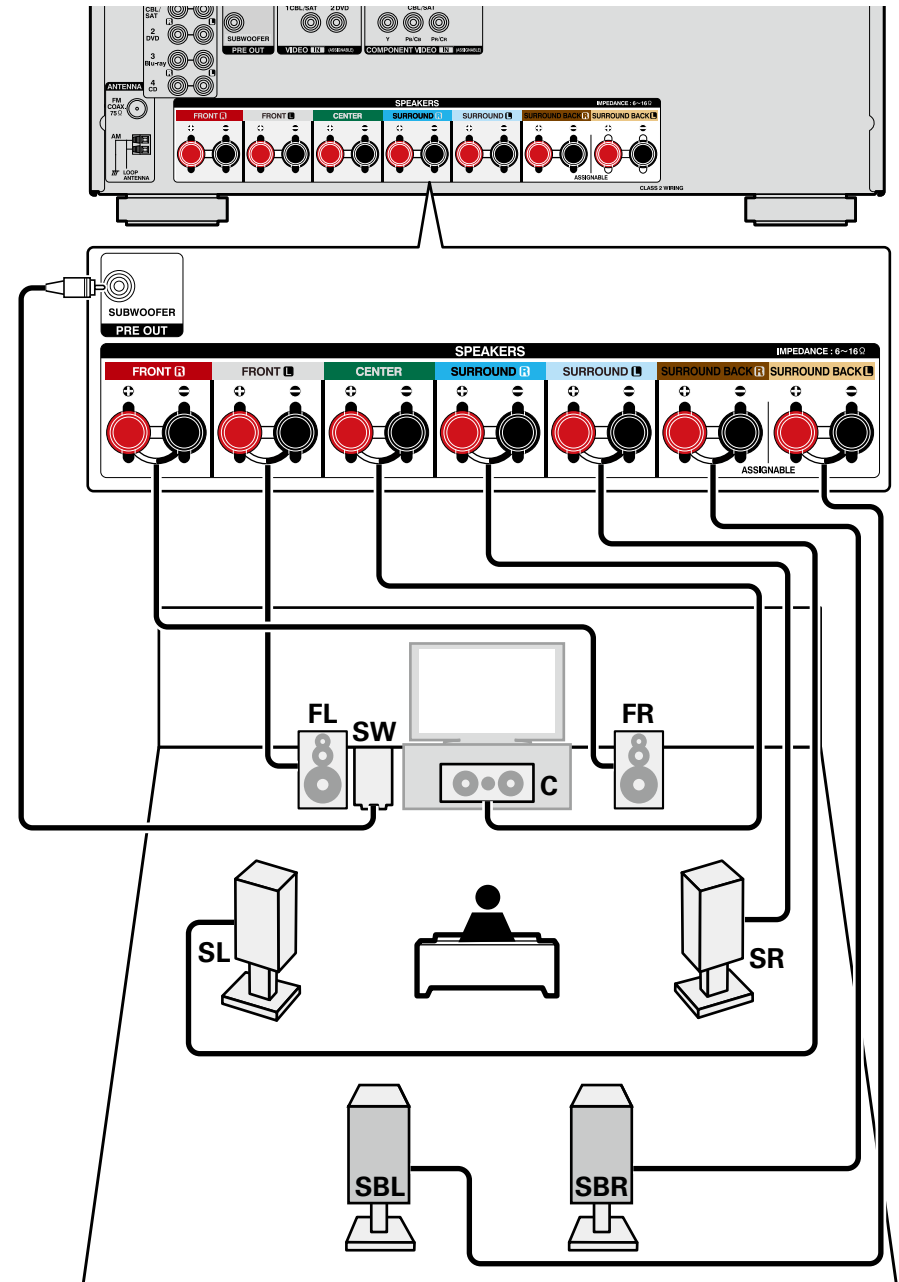



## Connecting 7.1-channel speakers using front height speakers

The illustration on the right shows a connection example for performing 7.1-channel playback using the front height speakers.

To perform 7.1-channel playback using the front height speaker, set "Assign Mode" to "Front Height" in steps 3 to 5 for "Set up "Amp Assign"" (page 86).

**NOTE**

- For speaker cable connections, see [page 79](#).
- For speaker impedance, see [page 79](#).

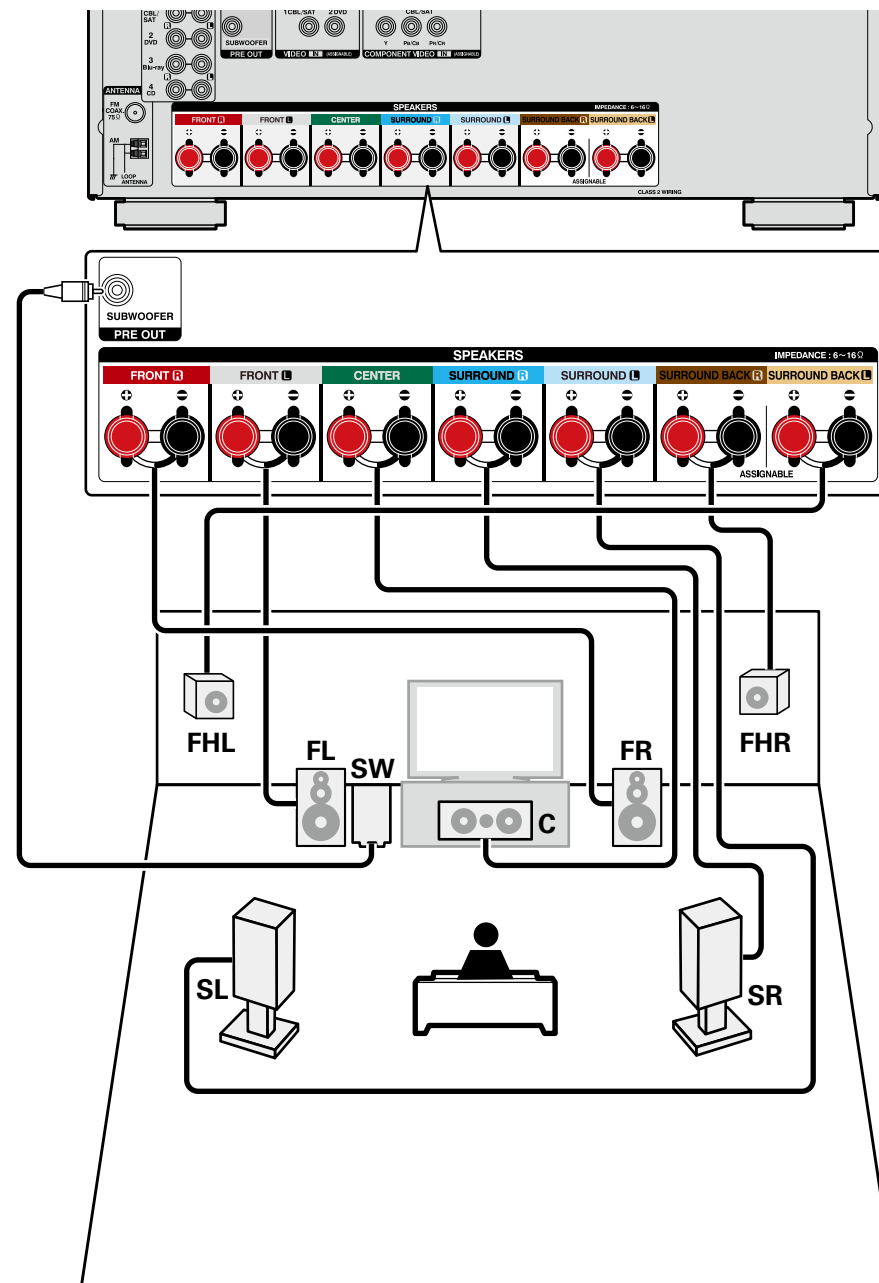

## Connecting 6.1-channel speakers using one surround back speaker

If using only one surround back speaker, connect to the "L" side of the SURROUND BACK terminal. For speaker settings in this case, see "When 6.1-channel speakers are installed" ([page 78](#)). To perform 6.1-channel playback using the surround back speaker, set "Assign Mode" to "Surround Back" in steps 3 to 5 for "Set up "Amp Assign"" ([page 86](#)). Also use the "Speaker Config." setting ([page 116](#)) to set "Surr. Back" to "1spkr".

### NOTE

- For speaker cable connections, see [page 79](#).
- For speaker impedance, see [page 79](#).

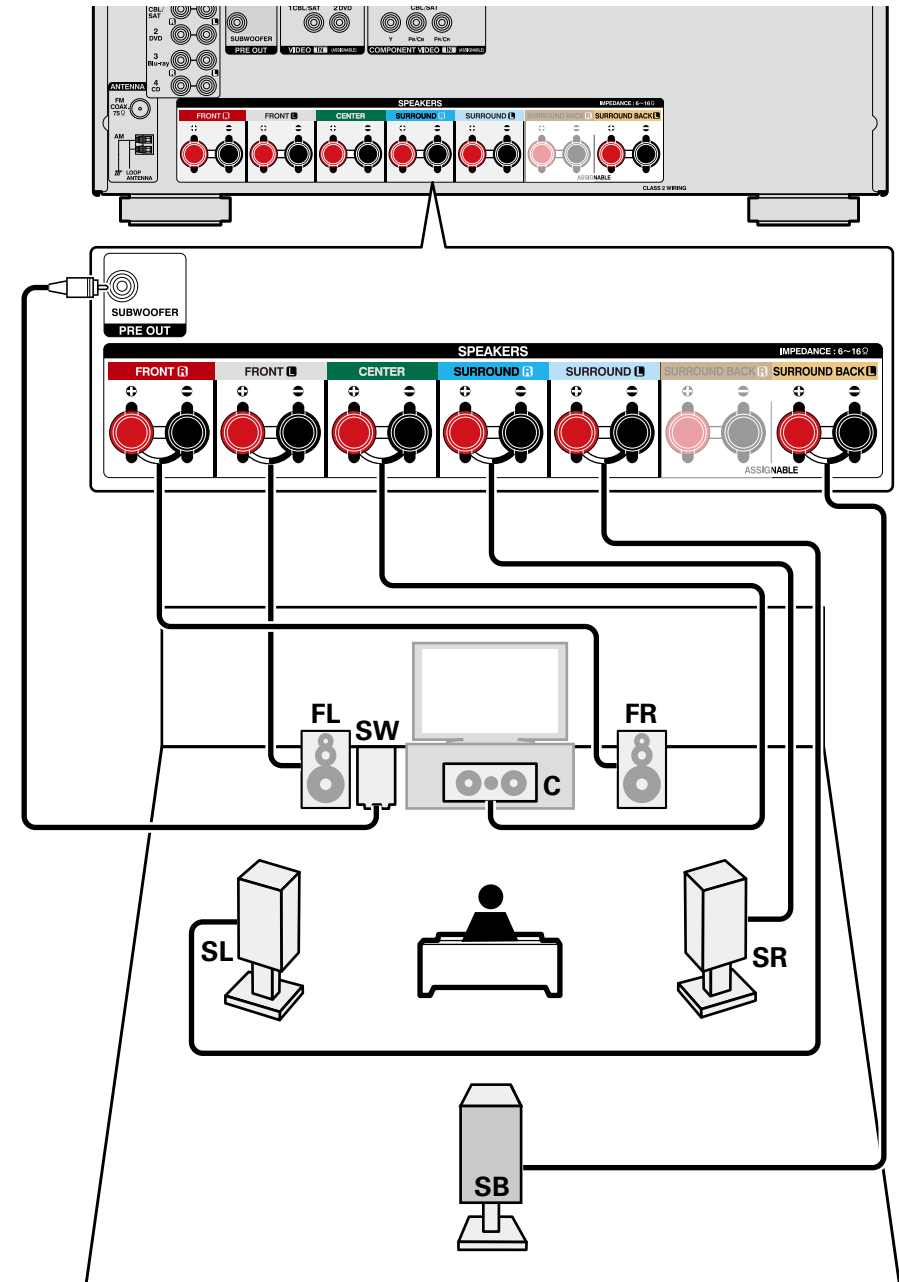

## Connecting 5.1-channel speakers

To perform 5.1-channel playback, set "Assign Mode" to "Surround Back" in steps 3 to 5 for "Set up "Amp Assign"" (page 86).

**NOTE**

- For speaker cable connections, see [page 79](#).
- For speaker impedance, see [page 79](#).

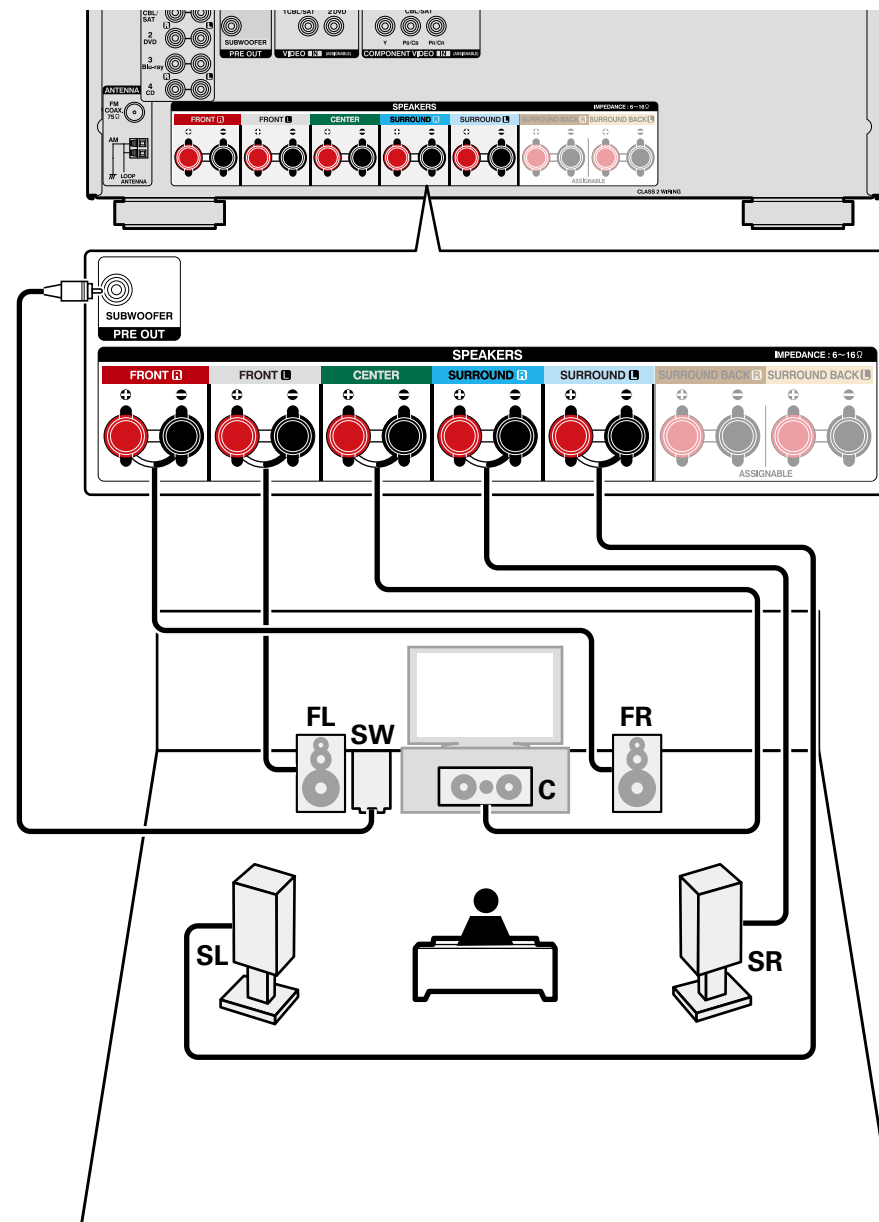

## Connecting 2.1-channel speakers

**NOTE**

- For speaker cable connections, see [page 79](#).
- For speaker impedance, see [page 79](#).

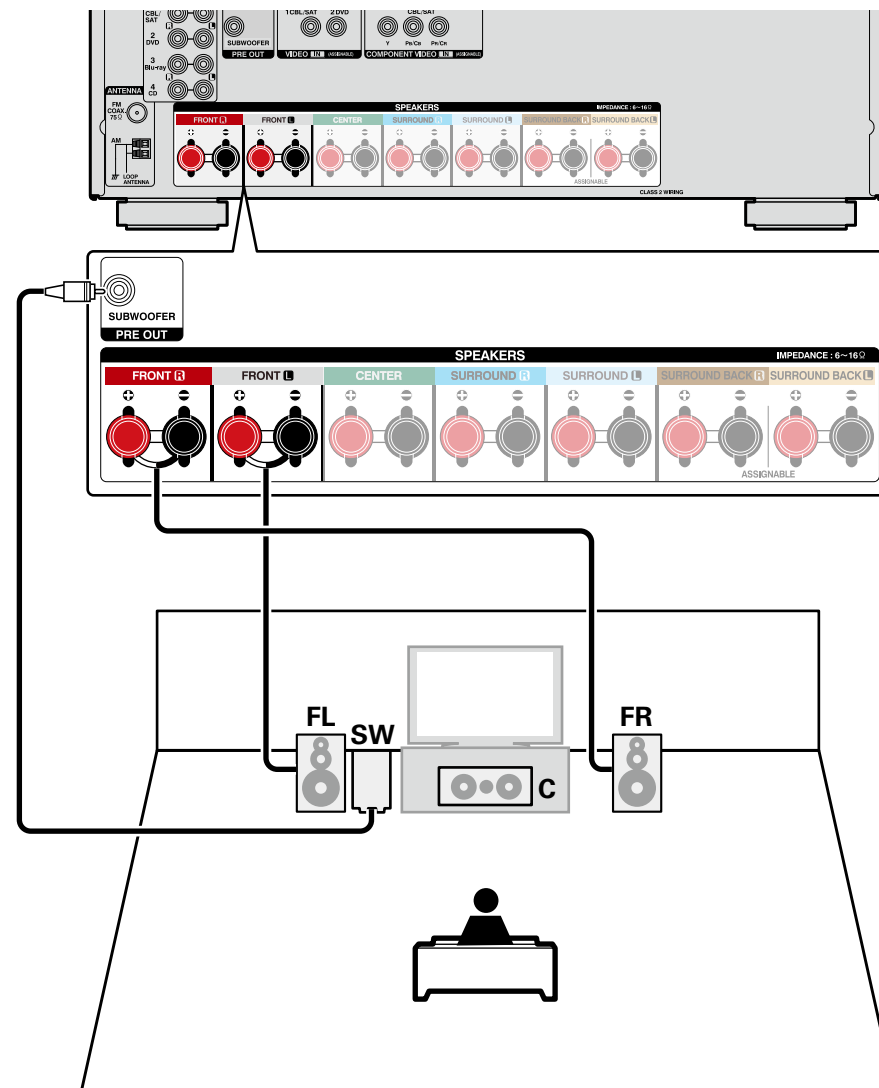

# Set up speakers

 around items indicate the settings.

This section describes detailed settings for Audyssey® Setup.

First install and connect the speakers to this unit.

Before Audyssey® Setup measurement, the settings shown below can be made.

- Changing the amplifier assignment (Amp Assign)

The signal output from the SURROUND BACK speaker terminals of this unit can be switched to match your speaker environment ([page 86](#) “Set up “Amp Assign””).

- Setting the channels to be used (Channel Select)

If channels that are not to be used are set in advance, measurement for the set channels is skipped, and measuring time can be reduced. You can also change the number of surround back speakers ([page 87](#) “Set up “Channel Select””).

**1** **Set up the zone mode**

Press **MAIN** to switch the zone mode.  
**MAIN** lights.

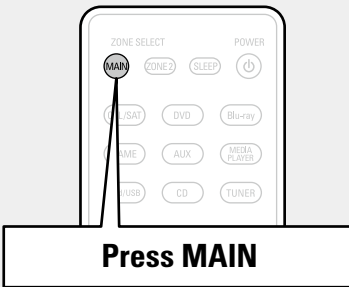

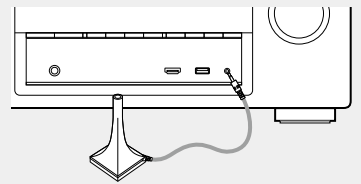

**Press MAIN**

**2** **Connect the Setup and measurement microphone.**



When the Setup and measurement microphone is connected, the following screen is displayed.



**3** **Set up “Amp Assign”**

Use  $\Delta$ / $\nabla$  to select “Amp Assign”, and then press **ENTER**.



**4** **Select “Assign Mode”, and then press ENTER.**

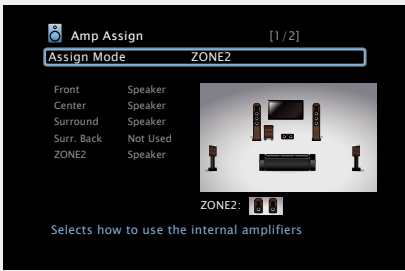

- 5** Use  $\triangleleft$   $\triangleright$  to select the configuration of the connected speakers, and then press **ENTER**.

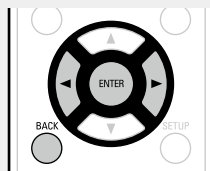

**Surround Back** Setting for 7.1-channel playback using surround back speakers.

**ZONE2** Setting to assign the unit's built-in power amplifier for ZONE2 and output the audio in stereo.

**Front Height** Setting for 7.1-channel playback using front height speakers.

- 6** Press  $\triangleleft$  or **BACK** to exit the “Amp Assign” setting.

## 7 Set up “Channel Select”

Use  $\triangle$   $\nabla$  to select “Channel Select”, and then press **ENTER**.

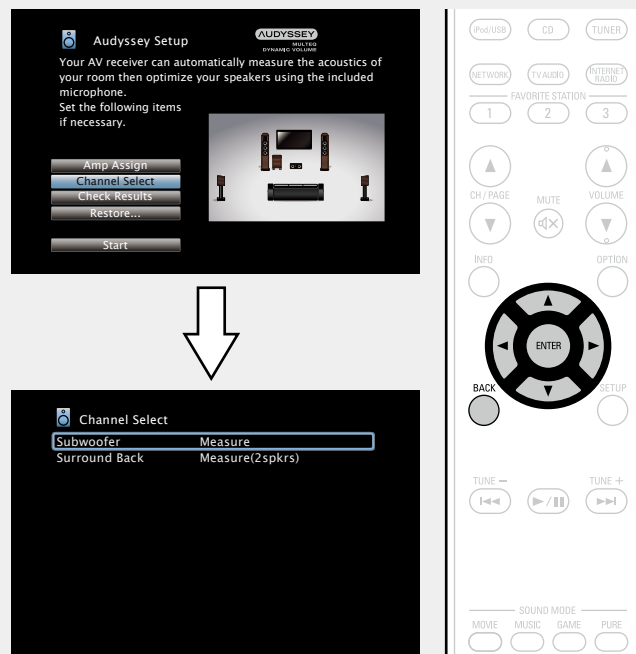

- 8** Use  $\triangle$   $\nabla$  to select a channel, and then press **ENTER**.

**Subwoofer** Select for no subwoofers to be used. In this case, go to step 9.

**Surround Back** Select the number of surround back speakers to be used. In this case, go to step 10.

- “Surround Back” can be set when “Assign Mode” is set to “Surround Back”.

- 9** Use  $\triangleleft$   $\triangleright$  to set whether or not a subwoofer channel is measured, and then press **ENTER**.

**Measure** Set for measuring a subwoofer.

**Skip** Set for no measuring of a subwoofer.

- 10** Use  $\triangleleft$   $\triangleright$  to set whether or not a surround back channel is measured, and then press **ENTER**.

**Measure (2spkr)** Set for measuring two surround back speakers.

**Measure (1spkr)** Set for measuring a surround back speaker.

**Skip** Set for no measuring of a surround back speaker.

- 11** Press  $\triangleleft$  or **BACK**. Proceed to [page 23](#) **Preparation** step 5.

### NOTE

After performing Audyssey® Setup, do not change the speaker connections or subwoofer volume. In event of a change, perform Audyssey® Setup again.

# Playback (Advanced operation)

Setup (👉 page 21)

Playback (Basic operation) (👉 page 28)

Selecting a listening mode (Sound Mode)  
(👉 page 71)

❑ HDMI control function (👉 page 88)

❑ Sleep timer function (👉 page 89)

❑ Quick select function (👉 page 90)

❑ Web control function (👉 page 91)

❑ Various memory functions (👉 page 92)

## HDMI control function

A recent addition to the HDMI standard is CEC, which allows control signals from one device to communicate with another device via the HDMI cable connection. Not all HDMI-equipped devices allow .

### ❑ Operations possible by HDMI control

- **This unit's power off function can be linked to the TV power off operation.**
- **You can switch audio output devices with a TV operation.**  
When you set "Output audio from amp" in the TV audio output setup operation, you can switch the AV receiver unit's power on.
- **You can adjust this unit's volume in the TV volume adjustment operation.**
- **You can switch this unit's input sources through linkage to TV input switching.**
- **When playing a disc player, this unit's input source switches to the appropriate source for that player.**
- **If you switch the input source of the unit to "TV AUDIO", you can play TV audio with this unit (👉 page 8 "About ARC (Audio Return Channel) function").**
- **When "HDMI Control" (👉 page 108) in the menu is set to "On", signals input to the HDMI input connector are output to the television or other device connected to the HDMI output connector, even if the power of this unit is in standby (pass-through function).**



To use this unit to play the audio of a TV that does not support the ARC function, connect the TV to this unit with an optical-digital or analog connection (👉 page 8).

### ❑ Setting procedure

- 1 Set the HDMI output connector corresponding with the HDMI control function.**  
Set "HDMI Control" (👉 page 108) to "On".
- 2 Turn the power on for all the devices connected by HDMI cable.**
- 3 Set the HDMI control function for all devices connected by HDMI cable.**
  - Please consult the operating instructions for the connected devices to check the settings.
  - Carry out steps 2 and 3 should any of the devices be unplugged.
- 4 Switch the television input to the HDMI input connected to this unit.**
- 5 Switch this unit input to the HDMI input source and check if the picture from the player is ok.**
- 6 When you turn the TV's power to standby, check that the power of this unit also goes to standby.**



If the HDMI control function does not operate properly, check the following points.

- Is the TV or player compatible with the HDMI control function?
- Is "HDMI Control" ([page 108](#)) set to "On"?
- Is "Power Off Control" ([page 108](#)) set to "All" or "Video"?
- Are the HDMI control function settings of all devices correct?

**NOTE**

- When "HDMI Control" is set to "On", it consumes more standby power.
- The HDMI control function controls operations of a TV that is compatible with the HDMI control function. Make sure that the TV and HDMI are connected when you perform HDMI control.
- Some functions may not operate depending on the connected TV or player. Check the owner's manual of each device for details beforehand.
- When "Power Off Control" on the menu is set to "Off" ([page 108](#)), this unit is not set to standby even if the connected device is in the standby mode.
- When connection changes are implemented, such as adding connections to HDMI devices, linked operations may be initialized. In this case, you will need to reconfigure the settings.
- When "HDMI Control" is set to "On", it is not possible to assign an HDMI connector to "TV AUDIO" at "Input Assign" ([page 112](#)).
- Should any of the operations below be performed, the interlocking function may be reset, in which case, repeat steps 2 and 3.
  - "Input Assign" – "HDMI" ([page 112](#)) setting has changed.
  - There is a change to the connection between the devices and the HDMI, or an increase in devices.

## Sleep timer function

- You can have the power automatically switched to standby once a set time has elapsed. This is convenient for viewing and listening while going to sleep.
- The sleep timer function can be set for each zone ([page 94](#) "Sleep timer function"). (The MAIN ZONE setting method is explained here.)

**1**

Press **MAIN** to switch the zone mode.

**MAIN** lights.

**2**

Press **SLEEP** and display the time you want to set.

The **SLEEP** indicator on the display lights.

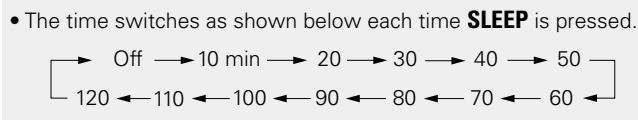

### To confirm the countdown time before putting the unit to sleep

Press **SLEEP**.

"Sleep : \*min" appears on the display.

\* Countdown time

### To cancel the sleep timer

Press **SLEEP** to set "Off".

The **SLEEP** indicator on the display turns off.



- The sleep timer setting is canceled if this unit's power is set to standby.
- The sleep timer function can be set separately for the different zones ([page 94](#) "Sleep timer function").

**NOTE**

The sleep timer function cannot turn off the power of devices connected to this unit. To turn off the power of those connected devices, set up sleep timers on the connected devices themselves.



## Quick select function

You can save settings such as the input source selection, volume level, and sound mode at the **QUICK SELECT 1 – 4** buttons.

You can simply press one of the set **QUICK SELECT** buttons for subsequent playback to switch to various saved settings all at once.

- By saving frequently used settings at the **QUICK SELECT 1 – 4** buttons, you will always be able to easily call up the same playback environment.

### Press QUICK SELECT.

The Quick Select settings for the button you pressed are called up.

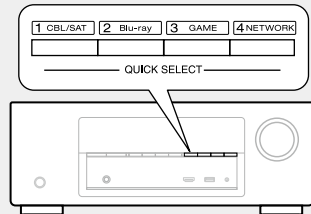

- The default settings of each Quick Select function are as shown below.

Button	Input source	Volume	Sound Mode
<b>QUICK SELECT 1</b>	CBL/SAT	40	STEREO
<b>QUICK SELECT 2</b>	Blu-ray	40	STEREO
<b>QUICK SELECT 3</b>	GAME	40	STEREO
<b>QUICK SELECT 4</b>	NETWORK	40	STEREO

### Changing the Quick Select Name

On this unit, you can change the Quick Select Name displayed on the menu to the name that you prefer.

For the name change method, see “Quick Select Names” ([page 125](#)).

## Changing the settings

### 1 Set the items below to the settings you want to save.

- ① Input source\* ([page 28](#))
- ② Volume ([page 29](#))
- ③ Sound Mode ([page 71](#))
- ④ Audyssey  
(Audyssey MultEQ®, Audyssey Dynamic EQ®, Audyssey Dynamic Volume®) ([page 104](#))

### 2 Press and hold the desired QUICK SELECT until “Quick\* Memory” appears on the display.

The current settings will be memorized.

- \* The number for the **QUICK SELECT** button you pressed is displayed.

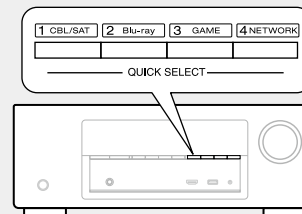

# Web control function

You can control this unit from a web control screen on a web browser.



- This unit and the PC need to be connected to the network properly (page 19 “Connecting to a home network (LAN)”) in order to use the web control function.
- Depending on the settings of your security-related software, you may not be able to access this unit from your PC. If this is the case, then change the settings of the security-related software.

**1** Switch the “IP Control” setting to “Always On” (page 120).

**2** Check the IP address of this unit with “Information” (page 120).

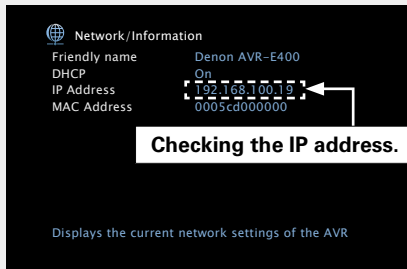

**3** Start up the web browser.

**4** Enter the IP address of this unit in browser’s address box.

For example, if the IP address of this unit is “192.168.100.19”, enter “http://192.168.100.19/”.

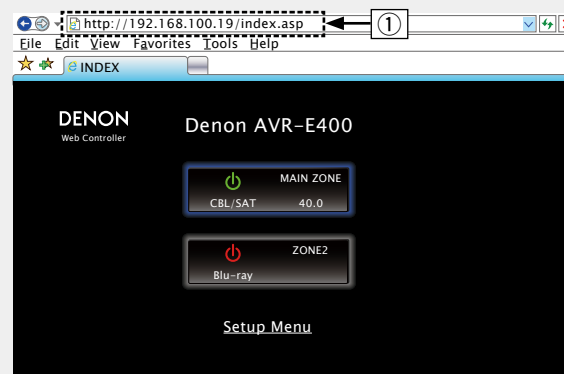

① Entering the IP address.

- By adding this unit’s IP address to the browser’s bookmark, you can display the web control screen using the bookmark function the next time you use the browser. If you are using a DHCP server and “IP Control” (page 120) is set to “Off In Standby”, turning the power on/off changes the IP address.

**5** When the top menu is displayed, click on the menu item you want to operate.

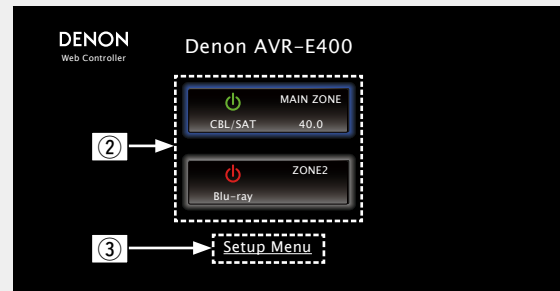

② Click when you select the zone to operate. (Example 1)

③ Click when you operate the setup menu. (Example 2)

**6** Operate.

[Example 1] MAIN ZONE control screen

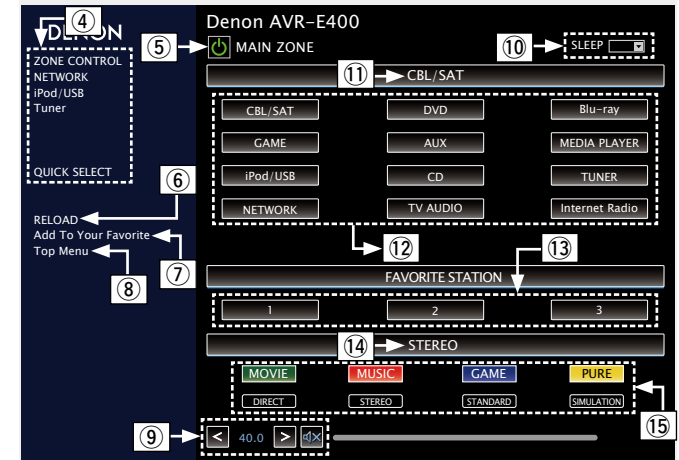

④ Click the menu item from which you want to make settings.

⑤ Click when you perform the power on/off function of the unit.

⑥ Click when you update to the latest information.

If changes are made during normal operation, then be sure to click this button to refresh the information with the latest status.

⑦ Click to add a setting to “Favorites” in your browser.

We recommend registering the setting screens for the different zones in the browser’s favorites so as not to accidentally perform menu operations for zones you do not intend to operate.

⑧ Click to return to the top menu.

⑨ To adjust the main volume, click “<”, “>”, or the volume display.

⑩ Click “v” to set the sleep timer function.

⑪ Displays the name of the selected input source.

⑫ Click a button to change the input source.

⑬ Callback your favorite content.

⑭ Displays the sound mode.

⑮ The sound mode switches when you click the button.

[Example 2] Setup menu screen

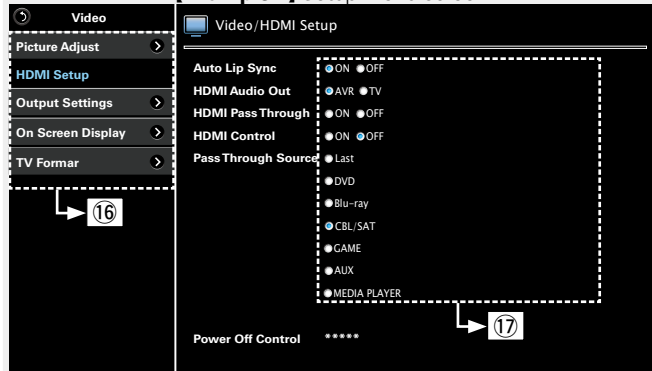

- 16 Click the menu item from which you want to make settings.  
The display on the right becomes the individual setting screens.
- 17 Click an item to make a setting.

[Example 3] Network audio operating screen

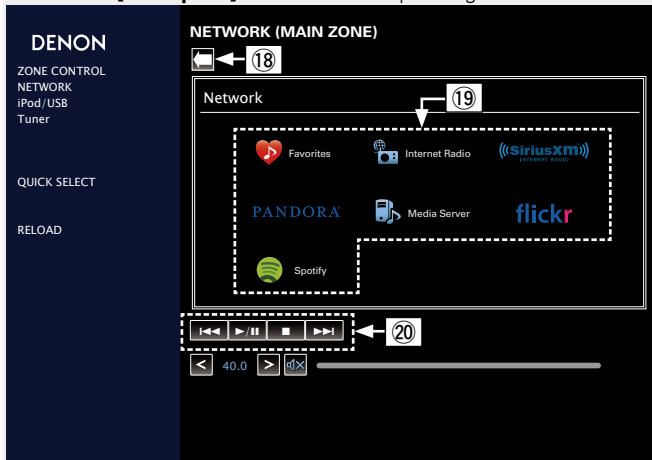

- 18 Click to return to the previous screen.
- 19 Click the content you want to operate.
- 20 Use to operate content.

## Various memory functions

### Personal memory plus function

This function sets the settings (input mode, sound mode, HDMI output mode, MultEQ®, Dynamic EQ, audio delay etc.) last selected for the individual input sources.



The surround parameters, tone control settings and the volumes of the different speakers are stored for the individual sound modes.

### Last function memory

This function stores the settings which were made before going into the standby mode.

When the power is turned back on, the settings are restored.

# Playback in ZONE2 (Separate room)

- You can operate this unit so as to enjoy audio in a room (ZONE2) other than the MAIN ZONE (room where the unit is located).
- You can simultaneously play back the same source in both the MAIN ZONE and ZONE2. You can also play back separate sources in the MAIN ZONE and ZONE2.

## Audio output

### Zone playback by speaker output

- Set the “Assign Mode” ([page 116](#)) setting to “ZONE2”, and outputs ZONE2 audio from SURROUND BACK speaker terminals (The default setting is “ZONE2”).
- If you set the “Assign Mode” ([page 116](#)) setting to “ZONE2”, the main zone home theater system can play back up to 5.1 channels. Even if you play back audio recorded in 6.1 or 7.1 channels, this unit automatically downmixes the audio to 5.1 channels.

#### Connecting and setting the speakers

“Assign Mode” setting ( <a href="#">page 116</a> ) and audio signals output	Connecting the speakers
<p><b>ZONE2</b> Output signal : Stereo (L / R)</p>	



When you connect a Blu-ray Disc player to the analog audio input terminal BD, you can listen to audio from the Blu-ray Disc player in ZONE2.

#### NOTE

It is not possible to play the digital audio signals input from the HDMI, COAXIAL or OPTICAL connectors in ZONE2. Play using analog connections (in stereo).

## Playback

**1 Press ZONE2 to switch the zone mode to the ZONE2. ZONE2 lights.**

**2 Press POWER to turn on the ZONE2 power.**

The **Z2** indicator on the display lights.

- Also press input source select button when in standby mode, the power turns on.
- When **POWER** is pressed, ZONE2 turns off.
- Power in ZONE2 can be turned on or off by pressing **ZONE2 ON/OFF** on the main unit.

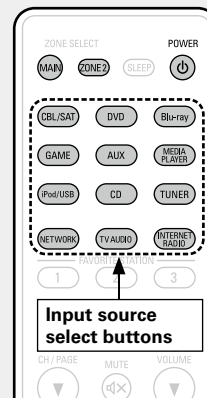

**3 Press the input source select button to select the input source to be played.**

The audio signal of the selected source is output to ZONE2.

- To perform an operation with the main unit, press **ZONE2 SOURCE** many times. Each time you press **ZONE2 SOURCE**, the input source changes.



When power for both MAIN ZONE and ZONE2 is set to ON, power of the MAIN ZONE only can be turned off. In Step 1, press **MAIN** and **POWER** in this order.

### Adjusting the volume

Use **VOLUME** ▲▼ to adjust the volume.

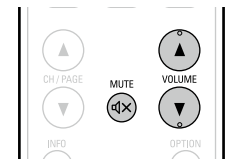

[Adjustable range] **0 – 40 – 98**

(When the “Scale” ([page 104](#)) setting is “0 – 98”)

[Adjustable range] **--- –79dB – –40dB – 18dB**

(When the “Scale” ([page 104](#)) setting is “–79.5dB – 18.0dB”)

- At time of purchase, “Volume Limit” ([page 124](#)) is set to “70 (–10dB)”.



Turn **MASTER VOLUME** after pressing **ZONE2 ON/OFF** on the main unit to adjust the sound volume.

### Turning off the sound temporarily

Press **MUTE** ◻✕.

The sound is reduced to the level set at “Mute Level” ([page 124](#)) in the menu.

- To cancel, either adjust the volume or press **MUTE** ◻✕ again.
- The setting can also be cancelled by adjusting the volume or turning off the ZONE2 power.



You can adjust the tone and volume for ZONE2 in “ZONE2 Setup” ([page 124](#)) in the menu.

## Sleep timer function

- This is convenient for viewing and listening while going to sleep in ZONE2.
- The sleep timer function can be set by zone.

**1** Press **ZONE2** to switch the zone mode.  
**ZONE2** lights.



**2** Press **SLEEP** and display the time you want to set.

- The time switches as shown below each time **SLEEP** is pressed.

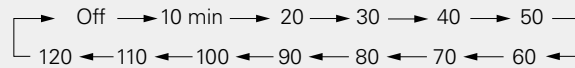

### To confirm the countdown time before putting the unit to sleep

Press **SLEEP**.

"Z2 Sleep : \*min" appears on the display.

\* Countdown time

### To cancel the sleep timer

Press **SLEEP** to set "Off".



The sleep timer is also cancelled when this unit is set to the standby mode or the ZONE2 power is turned off.

#### NOTE



The sleep timer function cannot turn off the power of devices connected to this unit. To turn off the power of those connected devices, set up sleep timers on the connected devices themselves.



# How to make detailed settings



## Menu map

For menu operation, connect a TV to this unit and display the menu on the TV screen. For menu operations, see the following page.

By default, this unit has recommended settings defined. You can customize this unit based on your existing system and your preferences.

Setting items	Detailed items	Description	Page
 Audio	<b>Dialog Level</b>	Adjusts and enhances the frequency band corresponding to the human voice at the center channel to make the voice clearer.	<a href="#">101</a>
	<b>Subwoofer Level</b>	This setting adjusts the volume level for the subwoofer.	<a href="#">101</a>
	<b>Surround Parameter</b>	Adjusts surround sound parameters.	<a href="#">101</a>
	<b>Tone</b>	Adjusts the tonal quality of the sound.	<a href="#">103</a>
	<b>Restorer</b>	Expands the low and high frequency components of compressed audio content such as MP3 files to enable richer audio playback.	<a href="#">103</a>
	<b>Audio Delay</b>	Compensates for incorrect timing between video and audio.	<a href="#">103</a>
	<b>Volume</b>	Set the MAIN ZONE (room where the unit is located) volume setting.	<a href="#">104</a>
	<b>Audyssey</b>	Makes Audyssey MultEQ <sup>®</sup> , Audyssey Dynamic EQ <sup>®</sup> and Audyssey Dynamic Volume <sup>®</sup> settings.	<a href="#">104</a>
	<b>Graphic EQ</b>	Uses the graphic equalizer to adjust the tone of each speaker.	<a href="#">105</a>
 Video	<b>Picture Adjust</b>	Adjusts the video quality.	<a href="#">107</a>
	<b>HDMI Setup</b>	Makes settings for HDMI video/audio output.	<a href="#">107</a>
	<b>Output Settings</b>	Makes screen-related settings.	<a href="#">108</a>
	<b>On Screen Display</b>	Select the on-screen display user interface preferences.	<a href="#">110</a>
	<b>TV Format</b>	Set the video output signal format for the TV you are using.	<a href="#">110</a>
 Inputs	<b>Input Assign</b>	Changes input connector assignment.	<a href="#">112</a>
	<b>Source Rename</b>	Changes the display name for this source.	<a href="#">114</a>
	<b>Hide Sources</b>	Remove from the display input sources that are not used.	<a href="#">114</a>
	<b>Source Level</b>	Adjusts the playback level of the audio input.	<a href="#">114</a>
	<b>Input Select</b>	Sets the audio input mode and decode mode.	<a href="#">114</a>

Setting items	Detailed items	Description	Page
 Speakers	<b>Audyssey<sup>®</sup> Setup</b>	The acoustic characteristics of the connected speakers and listening room are measured and the optimum settings are made automatically.	<a href="#">21</a> , <a href="#">86</a>
	<b>Manual Setup</b>	Perform when setting the speakers manually or when changing settings made in Audyssey <sup>®</sup> Setup.	<a href="#">116</a>
 Network	<b>Information</b>	Display network information.	<a href="#">120</a>
	<b>IP Control</b>	Enables network communication in standby power mode.	<a href="#">120</a>
	<b>Friendly Name</b>	The Friendly Name is the name of this unit displayed on the network. You can change the Friendly Name according to your preferences.	<a href="#">120</a>
	<b>Settings</b>	Make settings for wired LAN.	<a href="#">121</a>
	<b>Diagnostics</b>	Used to check the network connection.	<a href="#">122</a>

Setting items	Detailed items	Description	Page
 <b>General</b>	<b>Language</b>	Sets the language for display the menu on the TV screen.	<a href="#">124</a>
	<b>ZONE2 Setup</b>	Makes settings for audio playback in a ZONE2 system.	<a href="#">124</a>
	<b>Zone Rename</b>	Change the display title of each zone to one you prefer.	<a href="#">124</a>
	<b>Quick Select Names</b>	Change the "Quick Select" display title to one you prefer.	<a href="#">125</a>
	<b>Auto Standby</b>	When you do not perform any operation on this unit with no audio or video input for a specified time, this unit automatically enters the standby mode. Before it enters the standby mode, "Auto Standby" is displayed on the display of this unit and the menu screen.	<a href="#">125</a>
	<b>Front Display</b>	Makes settings related to the display on this unit.	<a href="#">125</a>
	<b>Information</b>	Show information about receiver settings, input signals, etc.	<a href="#">126</a>
	<b>Usage Data</b>	Selects whether or not to send anonymous usage data to Denon.	<a href="#">127</a>
	<b>Firmware</b>	Set whether or not to check for firmware update, update the firmware, and display update and upgrade notifications.	<a href="#">127</a>
	<b>Setup Lock</b>	Protect settings from inadvertent changes.	<a href="#">128</a>
 <b>Setup Assistant</b>	Perform the installation, connection, and setup procedures to prepare the unit for operation following guidance from the setup section of this manual.		 7

# Examples of menu screen displays

Typical examples are described below.

## [Example 1]

### Menu selection screen (Top menu)

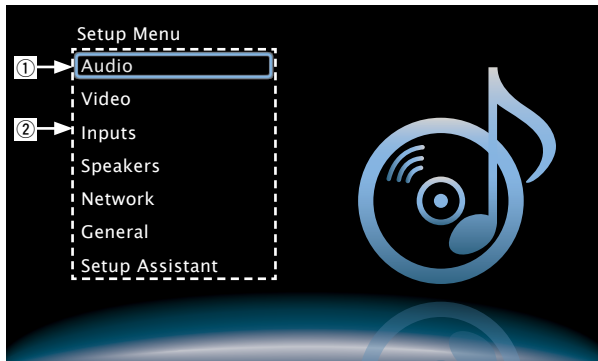

- ① Currently selected setup item
- ② List of GUI menu setup items

Use  $\Delta$ / $\nabla$  to select "Audio" and then press  $\triangleright$ .  
(Or press ENTER.)

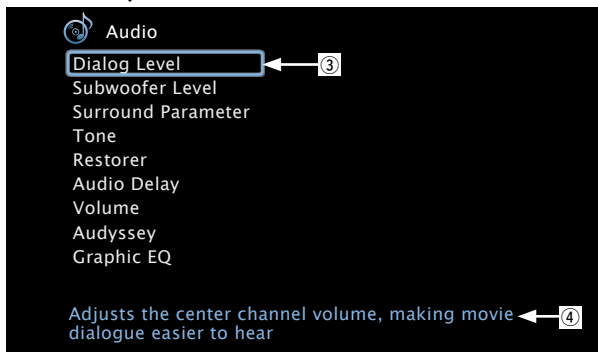
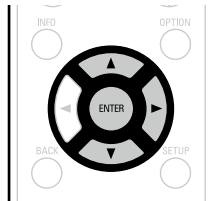

- ③ Selected setup item
- ④ Guide text for the currently selected setup item

## [Example 2]

### Audyssey® Setup screen (with illustration)

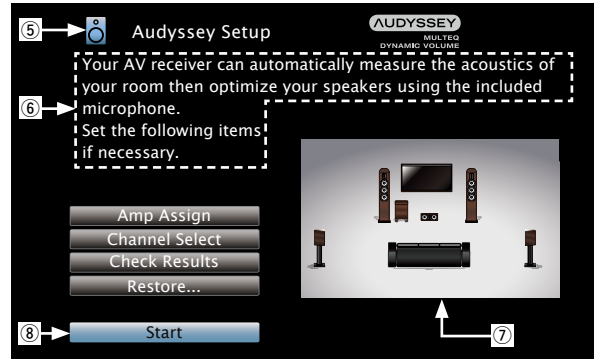

- ⑤ Currently selected setup icon
- ⑥ Operation guidance text
- ⑦ Illustration
- ⑧ Selected setup item







### NOTE

When the menu is operated on a computer's resolution (e.g. VGA) or during playback of certain 3D video content, the playback image switches to the menu screen image.

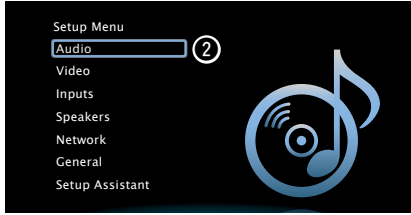

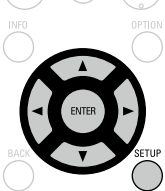
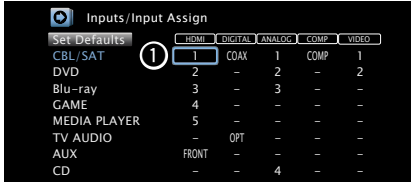
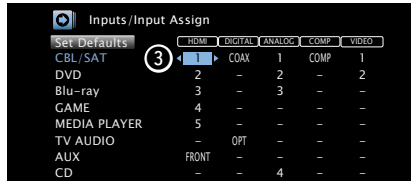
# Examples of menu and front display

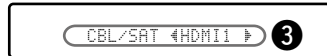
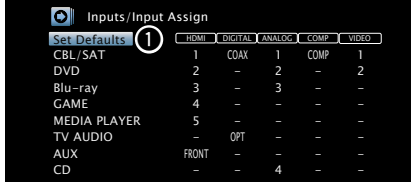
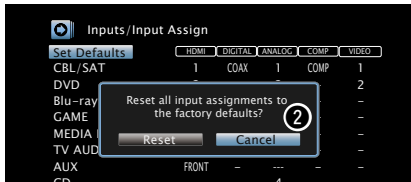
Below we describe typical examples of displays on the TV screen and on the set's display window.

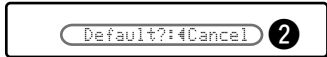
	Menu display	Front display	Description
<b>Top menu display</b>			<ol style="list-style-type: none"> <li>1 Press <b>SETUP</b> to display the menu screen.</li> <li>2 TV screen: Displays the selected line. Display: Displays the selected item. • Use <math>\Delta</math>/<math>\nabla</math> to move to the item you want to set.</li> </ol> 
<b>Display when changing settings</b>	 <p>Press <b>ENTER</b>.</p> 	 <p>Press <b>ENTER</b>.</p> 	<ol style="list-style-type: none"> <li>1 TV screen: Displays the selected line. Display: Displays the selected item. • Use <math>\Delta</math>/<math>\nabla</math> to move to the item you want to set.</li> <li>2 Press <b>ENTER</b> to set to the mode in which the setting can be made.</li> <li>3 <math>\leftarrow</math> <math>\rightarrow</math> is displayed at the sides of items whose setting can be changed. Use <math>\leftarrow</math>/<math>\rightarrow</math> to change to the desired setting.</li> </ol>
<b>Display when returning to the settings in effect at time of purchase</b>	 <p>Press <b>ENTER</b>.</p> 	 <p>Press <b>ENTER</b>.</p> 	<ol style="list-style-type: none"> <li>1 Press <math>\Delta</math> to select "Set Defaults" (TV screen) or "Default" (Display), then press <b>ENTER</b>.</li> <li>2 Press <math>\leftarrow</math> to select "Reset", then press <b>ENTER</b>.</li> </ol>

# Inputting characters

On this unit, you can change the name displayed on the following screens to the names that you prefer.

- Text Search (page 63)
- Preset Name (page 42)
- Source Rename (page 114)
- Friendly Name (page 120)
- Zone Rename (page 124)
- Quick Select Names (page 125)
- Character input for the network functions (page 45, 53, 55, 59, 61, 121)

## Keyboard screen

Select a character on the TV screen to input characters.

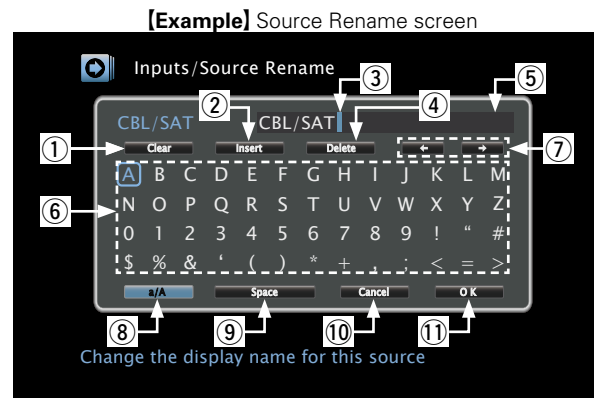

- 1 Clear key
- 2 Insert key
- 3 Cursor
- 4 Delete key
- 5 Character input section
- 6 Keyboard section
- 7 Cursor keys
- 8 Uppercase and lowercase switch key
- 9 Space key
- 10 Cancel key
- 11 OK key

## Input method

- 1 Display the screen for inputting characters (page 95 “Menu map”).

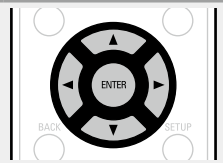

- 2 Select a character to be changed.
  - 1 Use  $\Delta \nabla \triangleleft \triangleright$  to select  $\leftarrow$  or  $\rightarrow$ .
  - 2 Press **ENTER** to place the cursor at the character to be changed. Each time **ENTER** is pressed, the cursor moves by one character.

- 3 Select a character to be input with  $\Delta \nabla \triangleleft \triangleright$  then press **ENTER**.

• The types of characters that can be input are as shown below.

### [Upper case characters/Numbers/Symbols]

ABCDEFGHIJKLMNOPQRSTUVWXYZ

0123456789

! " # \$ % & ' ( ) \* + , ; < = >

### [Lower case characters/Numbers/Symbols]

abcdefghijklmnopqrstuvwxyz

0123456789

. @ - \_ / : ~ ? [ \ ] ^ ' { | }

- 4 Repeat steps 2 and 3 to change the name.

- 5 Use  $\Delta \nabla \triangleleft \triangleright$  to select **OK**, then press **ENTER**.



Make audio-related settings.

## Menu operation

- 1** Press **MAIN** to switch the zone mode.  
**MAIN** lights.
- 2** Press **SETUP**.  
The menu is displayed on the TV screen.
- 3** Use  $\Delta$ / $\nabla$  to select the menu to be set or operated.
- 4** Press **ENTER** or  $\triangleright$  to enter the setting.

- To return to the previous item, press  $\triangleleft$  or **BACK**.
- Exiting the Menu, press **SETUP** while the menu is displayed.  
The menu display disappears.



## Items that can be set with the "Audio" procedure

**Dialog Level** ([page 101](#))

**Subwoofer Level** ([page 101](#))

**Surround Parameter** ([page 101](#))

**Tone** ([page 103](#))

**Restorer** ([page 103](#))

**Audio Delay** ([page 103](#))

**Volume** ([page 104](#))

**Audyssey** ([page 104](#))

**Graphic EQ** ([page 105](#))

## Dialog Level

Default settings are underlined.

Adjusts and enhances the frequency band corresponding to the human voice at the center channel to make the voice clearer.

Setting items	Setting details
Level	<u>-12dB – +12dB (0dB)</u>

## Subwoofer Level

Default settings are underlined.

This setting adjusts the volume level for the subwoofer.

Setting items	Setting details
<b>Subwoofer</b> Turn subwoofer output on and off.	<b>On</b> : The subwoofer is used. <b>Off</b> : The subwoofer is not used. <div style="text-align: center;"><b>NOTE</b></div> This can be set when the sound mode is "DIRECT" and "PURE DIRECT" ( <a href="#">page 71</a> ) and the "Subwoofer Mode" ( <a href="#">page 118</a> ) is "LFE+Main".
<b>Subwoofer Level</b> This setting adjusts the volume level for the subwoofer.	<u>-12dB – +12dB (0dB)</u>

## Surround Parameter

Default settings are underlined.

You can adjust the surround audio sound field effects to match your preferences.

The items (parameters) that can be adjusted depend on the signal being input and the currently set sound mode. For details on the adjustable parameters, see "Sound modes and surround parameters" ([page 136](#)).

### NOTE

- Some setting items cannot be set while playback is stopped. Make the settings during playback.
- When the sound mode is "PURE DIRECT", you cannot set the surround parameters.

Setting items	Setting details
<b>Cinema EQ</b> Gently softens the upper treble range of movie soundtracks to reduce possible harshness and improve clarity.	<b>On</b> : "Cinema EQ" is used. <b>Off</b> : "Cinema EQ" is not used.
<b>Loudness Management</b> This can be set in the Dolby TrueHD mode. This sets whether to output as specified in "Dynamic Compression" or output directly without compressing the dynamic range of audio recorded in the disc.	<b>On</b> : Outputs using the settings made in "Dynamic Compression" and "Dialogue Normalization" ( <a href="#">page 126</a> ) are enabled. <b>Off</b> : "Dynamic Compression" settings and "Dialogue Normalization" are disabled, and the signals on the disk are output as is.
<b>Dynamic Compression</b> Compress dynamic range (difference between loud and soft sounds).	<b>Auto</b> : Automatic dynamic range compression on/off control according to source. <b>Low / Medium / High</b> : These set the compression level. <b>Off</b> : Dynamic range compression is always off. <div style="text-align: center;"> You can set "Auto" only for the Dolby TrueHD source.</div>

Setting items	Setting details
<b>Low Frequency Effects</b> Adjust the low-frequency effects level (LFE).	<b>-10dB – 0dB</b> For proper playback of the different sources, we recommend setting to the values below. <ul style="list-style-type: none"> <li>• Dolby Digital sources : 0dB</li> <li>• DTS movie sources : 0dB</li> <li>• DTS music sources : -10dB</li> </ul>
<b>Center Image</b> Distributes the dialogue output from the center channel to the front left and right channels and widens the sound image in the front. You can set this when the sound mode is set to DTS NEO:6.	<b>0.0 – 1.0 (0.3)</b> The smaller the value, the more dialogue is concentrated on the center channel. The larger the value, the more dialogue is distributed to front left and right channels, and the more the sound image widens in the front.
<b>Panorama</b> Assign front L/R signals to also go to the surround channels for wider sound. You can set this when the sound mode is Dolby PLII in the "Music" mode.	<b>On</b> : Set. <b>Off</b> : Do not set.
<b>Dimension</b> Shift sound image center to front or rear to adjust playback balance. You can set this when the sound mode is Dolby PLII in the "Music" mode.	<b>0 – 6 (3)</b> As you set a smaller number, the surround sound field shifts backward; as you set a larger number, the surround sound field shifts forward.
<b>Center Width</b> Distributes the dialogue output from the center channel to left and right channels and widens the sound image in the front. You can set this when the sound mode is Dolby PLIIx in the "Music" mode.	<b>0 – 7 (3)</b> The smaller the value, the more dialogue is concentrated on the center channel. The larger the value, the more dialogue is distributed to front left and right channels, and the more the sound image widens in the front.

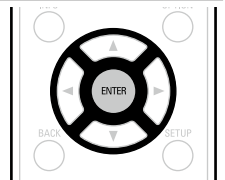

Setting items	Setting details
<b>Delay Time</b> Adjust the audio delay time against video to extend the sound field image. You can set this when the sound mode is "MATRIX".	<b>0ms – 300ms (30ms)</b>
<b>Effect Level</b> Adjust the sound effect level of the current listening mode.	<b>1 – 15 (10)</b> Set to a lower level if the positioning and sense of phase of the surround signals seems unnatural.
<b>Room Size</b> Determine size of acoustic environment. You can set this when the sound mode is one of the original listening modes.	<b>Small</b> : Simulate acoustics of a small room. <b>Medium small</b> : Simulate acoustics of a medium-small room. <b>Medium</b> : Simulate acoustics of a medium room. <b>Medium large</b> : Simulate acoustics of a medium-large room. <b>Large</b> : Simulate acoustics of a large room. <b>NOTE</b> "Room Size" does not indicate the size of the room in which sources are played.
<b>Height Gain</b> Control the front height channel volume.	<b>Low</b> : Reduce the front height channel volume. <b>Normal</b> : Front height channel sound is output with standard sound volume. <b>High</b> : Increase the front height channel volume. <b>NOTE</b> "Height Gain" is displayed for the following settings. <ul style="list-style-type: none"> <li>• When the "Speaker Config." – "Front Height" setting (<a href="#">page 116</a>) is set other than to "None".</li> <li>• When sound mode is "PLIIz" or the PLIIz decoder is used.</li> </ul>
<b>Set Defaults</b> The "Surround Parameter" settings are returned to the default settings.	<b>Reset</b> : Reset to the defaults. <b>Cancel</b> : Do not reset to the defaults. When you select "Set Defaults" and press <b>ENTER</b> , the "Reset all surround parameters to the factory defaults?" prompt is displayed. Select either "Reset" or "Cancel", and press <b>ENTER</b> .



## Tone

Default settings are underlined.

Adjust the tonal quality of the sound.

Setting items	Setting details
<b>Tone Control</b> Set the tone control function to "On" and "Off".	<p><b>On</b> : Allow tone adjustment (bass, treble).  <b>Off</b> : Playback without tone adjustment.</p> <p> "Tone Control" can be set when "Dynamic EQ" (<a href="#">page 105</a>) is set to "Off".</p> <p><b>NOTE</b></p> <ul style="list-style-type: none"> <li>• "Tone Control" settings are not reflected to ZONE2.</li> <li>• The tone cannot be adjusted in the "DIRECT" and "PURE DIRECT" mode.</li> <li>• The default setting differs depending on the sound mode.</li> </ul>
<b>Bass</b> Adjust bass.	<p><b>-6dB - +6dB</b></p> <p></p> <ul style="list-style-type: none"> <li>• "Bass" can be set when the menu "Tone Control" setting is "On".</li> <li>• The default setting differs depending on the sound mode.</li> </ul>
<b>Treble</b> Adjust treble.	<p><b>-6dB - +6dB</b></p> <p></p> <ul style="list-style-type: none"> <li>• "Treble" can be set when the menu "Tone Control" setting is "On".</li> <li>• The default setting differs depending on the sound mode.</li> </ul>

## Restorer

Compressed audio formats such as MP3, WMA (Windows Media Audio) and MPEG-4 AAC reduce the amount of data by eliminating signal components that are hard for the human ear to hear. The "Restorer" function generates the signals eliminated upon compression, restoring the sound to conditions near those of the original sound before compression. It also restores the original bass characteristics for a rich and expanded tonal range.

Setting items	Setting details
<b>Mode</b> Set the mode for "Restorer".	<p><b>High</b> : Optimized mode for compressed sources with very weak highs (64 kbps and under).  <b>Medium</b> : Apply suitable bass and treble boost for all compressed sources (96 kbps and under).  <b>Low</b> : Optimized mode for compressed sources with normal highs (96 kbps and over).  <b>Off</b> : Do not use "Restorer".</p> <p></p> <ul style="list-style-type: none"> <li>• This item can be set with analog signals or PCM signal (Sample Rate = 44.1/48 kHz) is input.</li> <li>• "Restorer" settings are stored for each input source.</li> <li>• This item default setting for "NETWORK" and "iPod/USB" is "Low". All others are set to "Off".</li> <li>• This cannot be set when the sound mode is set to "DIRECT" or "PURE DIRECT".</li> </ul>

## Audio Delay

Default settings are underlined.

While viewing video, manually adjust the time to delay audio output so that the video and audio are synchronized.

Setting details
<p><b>0ms - 200ms</b></p> <p></p> <ul style="list-style-type: none"> <li>• This item can be set within the range of 0 to 100 ms when "Auto Lip Sync" (<a href="#">page 107</a>) is set to "On" and when a TV compatible with Auto Lip Sync is connected.</li> <li>• Store "Audio Delay" for each input source.</li> <li>• Audio Delay for game mode can be set when "Video Mode" (<a href="#">page 108</a>) is set to "Auto" or "Game".</li> </ul>

## Volume

Default settings are underlined.

Set the MAIN ZONE (room where the unit is located) volume setting.

Setting items	Setting details
<b>Scale</b> Set how volume is displayed.	<b><u>0 – 98</u></b> : Display in the range 0 (Min) to 98. <b><u>-79.5dB – 18.0dB</u></b> : Display –dB (Min), in the range –79.5 dB to 18.0 dB.  <ul style="list-style-type: none"> <li>The “Scale” setting is applied also to the “Limit” and “Power On Level” display method.</li> <li>The “Scale” setting applies to all zones.</li> </ul>
<b>Limit</b> Make a setting for maximum volume.	<b><u>60 (-20dB) / 70 (-10dB) / 80 (0dB)</u></b> <b><u>Off</u></b> : Do not set a maximum volume.
<b>Power On Level</b> Define the volume setting that is active when the power is turned on.	<b><u>Last</u></b> : Use the memorized setting from the last session. <b><u>Mute</u></b> : Always use the muting on condition when power is turned on. <b><u>1 – 98 (-79dB – 18dB)</u></b> : The volume is adjusted to the set level.
<b>Mute Level</b> Set the amount of attenuation when muting is on.	<b><u>Full</u></b> : The sound is muted entirely. <b><u>-40dB</u></b> : The sound is attenuated by 40 dB down. <b><u>-20dB</u></b> : The sound is attenuated by 20 dB down.

## Audyssey

Default settings are underlined.

Set Audyssey MultEQ®, Audyssey Dynamic EQ® and Audyssey Dynamic Volume®. These can be selected after Audyssey® Setup has been performed. For additional information on Audyssey technology, please see [page 142](#).



### NOTE

- If you have not performed Audyssey® Setup, or if you change the speaker settings after performing Audyssey® Setup, you may not be able to select Dynamic EQ/Dynamic Volume. In this case, either perform Audyssey® Setup over again or perform “Restore...” ([page 27](#)) to return to the settings after Audyssey® Setup was run.
- When HD Audio for which the sampling frequency exceeds 96 kHz is played back, the “Audyssey” cannot be set.

Setting items	Setting details
<b>MultEQ®</b> MultEQ® compensates for both time and frequency characteristics of the listening area based on Audyssey® Setup measurement results. Selection is done from three types of compensation curves. We recommend the “Audyssey” setting. MultEQ® is the prerequisite function for Dynamic EQ and Dynamic Volume.	<b><u>Audyssey</u></b> : Optimize the frequency response of all speakers. <b><u>Audyssey Byp. L/R</u></b> : Optimize frequency response of speakers except front L and R speakers. <b><u>Audyssey Flat</u></b> : Optimize frequency response of all speakers to flat response. <b><u>Graphic EQ</u></b> : Apply frequency response set with “Graphic EQ” ( <a href="#">page 105</a> ). <b><u>Off</u></b> : Turn “MultEQ®” equalizer off.  “Audyssey”, “Audyssey Byp. L/R” and “Audyssey Flat” can be selected after Audyssey® Setup has been performed. “Audyssey” is automatically selected after performing Audyssey® Setup. When “Audyssey”, “Audyssey Byp. L/R” or “Audyssey Flat” is selected, <b>AUDYSSEY</b> illuminates. <b>NOTE</b> When using headphones, “MultEQ®” is automatically set to “Off”.





“MultEQ®”, “Dynamic EQ” and “Dynamic Volume” settings are stored for each input source.

Setting items	Setting details
<p><b>Dynamic EQ</b> Solves the problem of deteriorating sound quality as volume is decreased by taking into account human perception and room acoustics. Works with MultEQ®.</p>	<p><b>On</b> : Use Dynamic EQ. <b>Off</b> : Do not use Dynamic EQ.</p> <p> <b>AUDYSSEY</b> is displayed when set to "On".</p> <p><b>NOTE</b> When the menu "Dynamic EQ" setting is "On", it is not possible to do "Tone Control" (<a href="#">page 103</a>) adjustment.</p>
<p><b>Reference Level Offset</b> Audyssey Dynamic EQ® is referenced to the standard film mix level. It makes adjustments to maintain the reference response and surround envelopment when the volume is turned down from 0 dB. However, film reference level is not always used in music or other non-film content. Dynamic EQ Reference Level Offset provides three offsets from the film level reference (5 dB, 10 dB, and 15 dB) that can be selected when the mix level of the content is not within the standard. Recommended setting levels are shown at right.</p>	<p><b>0dB</b> (Film Ref) : This is the default setting and should be used when listening to movies. <b>5dB</b> : Select this setting for content that has a very wide dynamic range, such as classical music. <b>10dB</b> : Select this setting for jazz or other music that has a wider dynamic range. This setting should also be selected for TV content as that is usually mixed at 10 dB below film reference. <b>15dB</b> : Select this setting for pop/rock music or other program material that is mixed at very high listening levels and has a compressed dynamic range.</p> <p> Setting is enabled when "Dynamic EQ" is "On" (<a href="#">page 105</a>).</p>
<p><b>Dynamic Volume</b> Solves the problem of large variations in volume level between TV, movies and other content (between quiet passages and loud passages, etc.) by automatically adjusting to the user's preferred volume setting.</p>	<p><b>Heavy</b> : Most adjustment to softest and loudest sounds. <b>Medium</b> : Medium adjustment to loudest and softest sound. <b>Light</b> : Least adjustment to loudest and softest sounds. <b>Off</b> : Do not use "Dynamic Volume".</p> <p> <b>AUDYSSEY</b> is displayed when set to "Heavy", "Medium" or "Light".</p> <p>• If "Dynamic Volume" is set to "Yes" in "Audyssey® Setup" (<a href="#">page 25</a>), the setting is automatically changed to "Medium".</p>

## Graphic EQ

Default settings are underlined.

Use the 9 band graphic equalizer to adjust the tone of each speaker. "Graphic EQ" can be set when "MultEQ®" setting ([page 104](#)) is "Graphic EQ".

Setting items	Setting details
<p><b>Speaker Selection</b> Select whether to adjust tones for individual speakers or for all speakers.</p>	<p><b>All</b> : Adjust the tone of all speakers together. <b>Left/Right</b> : Adjust the tone of left and right speakers together. <b>Each</b> : Adjust the tone of each speaker.</p>
<p><b>Adjust EQ</b> Adjust tonal balance for each frequency band. Adjust the speaker selected in "Speaker Selection".</p>	<p>① Select the speaker. • Select the speakers you want to adjust when "Left/Right" or "Each" is selected. ② Select the adjustment frequency band. <b>63Hz / 125Hz / 250Hz / 500Hz / 1kHz / 2kHz / 4kHz / 8kHz / 16kHz</b> ③ Adjust the level. <b>-20.0dB - +6.0dB (0.0dB)</b></p>
<p><b>Curve Copy</b> Copy "Audyssey Flat" (<a href="#">page 104</a>) curve from MultEQ®.</p>	<p><b>Yes</b> : Copy. <b>No</b> : Do not copy.</p> <p> <b>"Curve Copy"</b> is displayed after Audyssey® Setup has been performed.</p> <p>• When you select "Curve Copy" and press <b>ENTER</b>, the "Copy "Audyssey Flat"?" prompt is displayed. Select either "Yes" or "No", and press <b>ENTER</b>.</p>
<p><b>Set Defaults</b> The "Graphic EQ" settings are returned to the default settings.</p>	<p><b>Reset</b> : Reset to the defaults. <b>Cancel</b> : Do not reset to the defaults.</p> <p> When you select "Set Defaults" and press <b>ENTER</b>, the "Reset to the default values?" prompt is displayed. Select either "Reset" or "Cancel", and press <b>ENTER</b>.</p>

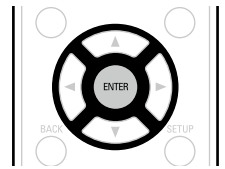





Make video-related settings.

## Menu operation

- 1** Press **MAIN** to switch the zone mode.  
**MAIN** lights.
- 2** Press **SETUP**.  
The menu is displayed on the TV screen.
- 3** Use  $\Delta$ / $\nabla$  to select the menu to be set or operated.
- 4** Press **ENTER** or  $\triangleright$  to enter the setting.
  - To return to the previous item, press  $\triangleleft$  or **BACK**.
  - Exiting the Menu, press **SETUP** while the menu is displayed.  
The menu display disappears.



## Items that can be set with the "Video" procedure

Picture Adjust ([page 107](#))

HDMI Setup ([page 107](#))

Output Settings ([page 108](#))

On Screen Display ([page 110](#))

TV Format ([page 110](#))





## Picture Adjust



Default settings are underlined.

Picture quality can be adjusted.

We recommend leaving the settings unchanged from the default settings. First adjust the display image quality on your TV, and use this menu only when you want to make fine adjustments.

- This item can be set when the input source is **CBL/SAT** **DVD** **Blu-ray** **GAME** **AUX** **MEDIA PLAYER** **iPod/USB** **NETWORK**.
- Can be set when the "Video Conversion" setting ([page 108](#)) is "On".
- "TV AUDIO" or "CD" can be set when "HDMI", "COMP" or "VIDEO" ([page 112, 113](#)) has been assigned.

Setting items	Setting details
<b>Picture Mode</b> Select the desired picture mode according to the video content and your viewing environment.	<b>Standard</b> : The standard mode suited for most living room viewing environments. <b>Movie</b> : A mode suited for watching movies in a dark room such as a theater room. <b>Vivid</b> : A mode that makes graphic images for games, etc. brighter and more vivid. <b>Streaming</b> : A mode suited for low bit rate video sources. <b>Custom</b> : Adjusts the picture quality manually. <b>Off</b> : No picture quality adjustment is done with this unit.  <ul style="list-style-type: none"> <li>• You can also press <b>OPTION</b> to make these settings from "Picture Mode" (<a href="#">page 67</a>) in the option menu.</li> <li>• The default settings are as follows.               <ul style="list-style-type: none"> <li>• For "NETWORK" and "iPod/USB" input sources : Streaming</li> <li>• For input sources other than "Network" and "iPod/USB" : Off</li> </ul> </li> </ul>
<b>Contrast</b> Adjust picture contrast.	<b>-6 - +6 (0)</b>  "Contrast" can be set when "Picture Mode" is set to "Custom".
<b>Brightness</b> Adjust picture brightness.	<b>0 - +12</b>  "Brightness" can be set when "Picture Mode" is set to "Custom".
<b>Saturation</b> Adjust picture chroma level (color saturation).	<b>-6 - +6 (0)</b>  "Saturation" can be set when "Picture Mode" is set to "Custom".
<b>Hue</b> Adjust green and red balance. Also called Tint.	<b>-6 - +6 (0)</b>  "Hue" can be set when "Picture Mode" is set to "Custom".

Setting items	Setting details
<b>Noise Reduction</b> Reduce overall video noise.	<b>Low / Medium / High / Off</b>  "Noise Reduction" can be set when "Picture Mode" is set to "Custom".
<b>Enhancer</b> Emphasize picture sharpness.	<b>0 - +12</b>  "Enhancer" can be set when "Picture Mode" is set to "Custom".







"Picture Adjust" can not be set when 4K signals are input.

## HDMI Setup

Default settings are underlined.

Make settings for HDMI video/audio output.

Setting items	Setting details
<b>Auto Lip Sync</b> Make automatic compensation for timing shift in audio and video output.	<b>On</b> : Compensated. <b>Off</b> : Not compensated.
<b>HDMI Audio Out</b> Select HDMI audio output device.	<b>AVR</b> : Play back through speakers connected to the unit. <b>TV</b> : Play back through TV connected to the unit.  <ul style="list-style-type: none"> <li>• When the HDMI control function is activated, priority is given to the TV audio setting (<a href="#">page 88</a> "HDMI control function").</li> <li>• When the power of this unit is on and "HDMI Audio Out" is set to "TV", audio is output as 2-channel from the HDMI OUT connector.</li> </ul>
<b>HDMI Pass Through</b> Selects how the AV receiver will pass HDMI signals to the HDMI output in standby power mode.	<b>On</b> : Passes the selected HDMI input through the AV receiver's HDMI output when the AV receiver is in standby power mode. <b>Off</b> : No HDMI signals are passed through the AV receiver's HDMI output in standby power mode. <div style="background-color: #e91e63; color: white; padding: 2px; text-align: center; font-weight: bold;">NOTE</div> <b>When "HDMI Pass Through" is set to "On", it consumes more standby power.</b> If you are not using this unit for an extended period, it is recommended that you unplug the power cord from the power outlet.

Setting items	Setting details
<p><b>HDMI Control</b> You can link operations with devices connected to HDMI and compatible with HDMI Control.</p>	<p><b>On</b> : Use HDMI control function. <b>Off</b> : Do not use HDMI control function.</p> <p></p> <ul style="list-style-type: none"> <li>When a device that is not compatible with the HDMI control function is connected, set "HDMI Control" to "Off".</li> <li>Please consult the operating instructions for each connected device to check the settings.</li> <li>Refer to "HDMI control function" (<a href="#">page 88</a>) for more information about the HDMI control function.</li> </ul> <p><b>NOTE</b></p> <ul style="list-style-type: none"> <li><b>When "HDMI Control" is set to "On", it consumes more standby power.</b> If you are not using this unit for an extended period, it is recommended that you unplug the power cord from the power outlet.</li> <li>The HDMI control function controls operations of a TV that is compatible with the HDMI control function. Make sure that the TV and HDMI are connected when you perform HDMI control.</li> <li>If the "HDMI Control" settings have been changed, always reset the power to connected devices after the change.</li> </ul>
<p><b>Pass Through Source</b> The AV receiver will "pass through" the sources HDMI signal when in standby.</p>	<p><b>Last</b> : Choose this option to "pass through" the last used HDMI input video source. <b>CBL/SAT / DVD / Blu-ray / GAME / AUX / MEDIA PLAYER / CD*</b> : Choose one of these HDMI sources to be passed through when the AV receiver is in standby. * "Pass Through Source" can be set when any of the HDMI connectors is assigned to "CD" for the input source in the "Input Assign" (<a href="#">page 112</a>) setting.</p> <p> "Pass Through Source" can be set when "HDMI Control" is set to "On" or "HDMI Pass Through" is set to "On".</p>
<p><b>Power Off Control</b> Links the power standby of this unit to external devices.</p>	<p><b>All</b> : If power to a connected TV is turned off independently of the input source, power to this unit is automatically set to standby. <b>Video</b> : When the TV is turned off with one of "HDMI", "COMP" or "VIDEO" (<a href="#">page 112, 113</a>) assigned for the CBL/SAT / DVD / Blu-ray / GAME / AUX / MEDIA PLAYER / CD / TV AUDIO input source on this unit, power to this unit is automatically set to standby. <b>Off</b> : This unit does not link with power to a TV.</p> <p> "Power Off Control" can be set when "HDMI Control" is set to "On".</p>

## Output Settings



Default settings are underlined.



Makes screen-related settings.



\* "CBL/SAT", "DVD", "Blu-ray", "GAME", "AUX", "MEDIA PLAYER", "CD" or "TV AUDIO" can be set when "HDMI", "COMP" or "VIDEO" ([page 112, 113](#)) has been assigned.



"Output Settings" can not be set when 4K signals are input.

Setting items	Setting details
<p><b>Video Mode</b> Make settings for video processing.</p> <p>CBL/SAT * DVD * Blu-ray * GAME * AUX * MEDIA PLAYER * CD * TV AUDIO *</p>	<p><b>Auto</b> : Process video automatically based on the HDMI content information. <b>Game</b> : Always process video for game content. <b>Movie</b> : Always process video for movie content.</p> <p></p> <ul style="list-style-type: none"> <li>If "Video Mode" is set to "Auto", the mode is switched according to the input contents.</li> <li>If a source is played in both MAIN ZONE (audio and video) and ZONE2 (audio only) modes in the same room, audio in MAIN ZONE and ZONE2 modes may sound out of synchronization, but this is not malfunction. In this case, setting to "Game" mode may improve audio synchronization.</li> </ul>
<p><b>Video Conversion</b> The input video signal is converted automatically in conjunction with the connected TV (<a href="#">page 6</a> "Converting input video signals for HD output (Video conversion function)").</p> <p>CBL/SAT * DVD * Blu-ray * GAME * AUX * MEDIA PLAYER * CD * TV AUDIO *</p>	<p><b>On</b> : The input video signal is converted. <b>Off</b> : The input video signal is not converted.</p> <p></p> <ul style="list-style-type: none"> <li>When a non-standard video signal from a game console or some other source is input, the video conversion function might not operate. In this case set "Video Conversion" to "Off".</li> <li>When "Video Conversion" is set to "Off", the video conversion function does not work.</li> </ul>

Setting items	Setting details																				
<b>i/p Scaler</b> Convert the input source resolution to the resolution set. <table border="1"> <tr><td>CBL/SAT</td><td>*</td><td>DVD</td><td>*</td></tr> <tr><td>Blu-ray</td><td>*</td><td>GAME</td><td>*</td></tr> <tr><td>AUX</td><td>*</td><td>MEDIA PLAYER</td><td>*</td></tr> <tr><td>iPod/USB</td><td></td><td>CD</td><td>*</td></tr> <tr><td>NETWORK</td><td></td><td>TV AUDIO</td><td>*</td></tr> </table>	CBL/SAT	*	DVD	*	Blu-ray	*	GAME	*	AUX	*	MEDIA PLAYER	*	iPod/USB		CD	*	NETWORK		TV AUDIO	*	<input type="checkbox"/> <b>When the input source is set other than "iPod/USB" and "NETWORK"</b> <b>Analog</b> : Use i/p (interlace-to-progressive) scaler function for analog video signals. <b>Analog &amp; HDMI</b> : Use i/p scaler function for analog and HDMI video signals. <b>HDMI</b> : Use i/p scaler function for HDMI video signals. <b>Off</b> : Do not use i/p scaler function. <input type="checkbox"/> <b>When the input source is set to "iPod/USB" and "NETWORK"</b> <b>On</b> : Use i/p scaler function. <b>Off</b> : Do not use i/p scaler function.  <ul style="list-style-type: none"> <li>• "Analog &amp; HDMI" can be set for input sources for which an HDMI input connector is assigned.</li> <li>• Which items can be set depend on the input source assigned to each input connector.</li> <li>• This function is not effective when the input signal is "x.v.Color", 3D, sYCC 601 color, Adobe RGB color, Adobe YCC 601 color or computer resolutions.</li> </ul>
CBL/SAT	*	DVD	*																		
Blu-ray	*	GAME	*																		
AUX	*	MEDIA PLAYER	*																		
iPod/USB		CD	*																		
NETWORK		TV AUDIO	*																		
<b>Resolution</b> Set the output resolution. You can set "Resolution" separately for HDMI output of the analog video input and HDMI input. <table border="1"> <tr><td>CBL/SAT</td><td>*</td><td>DVD</td><td>*</td></tr> <tr><td>Blu-ray</td><td>*</td><td>GAME</td><td>*</td></tr> <tr><td>AUX</td><td>*</td><td>MEDIA PLAYER</td><td>*</td></tr> <tr><td>iPod/USB</td><td></td><td>CD</td><td>*</td></tr> <tr><td>NETWORK</td><td></td><td>TV AUDIO</td><td>*</td></tr> </table>	CBL/SAT	*	DVD	*	Blu-ray	*	GAME	*	AUX	*	MEDIA PLAYER	*	iPod/USB		CD	*	NETWORK		TV AUDIO	*	<b>Auto</b> : The number of pixels the TV connected to the HDMI MONITOR OUT connector supports is detected automatically and the appropriate output resolution is set. <b>480p/576p / 1080i / 720p / 1080p / 1080p:24Hz / 4K</b> : Set the output resolution.  <ul style="list-style-type: none"> <li>• This item can be set when "i/p Scaler" is set to anything other than "Off".</li> <li>• When "i/p Scaler" is set to "Analog &amp; HDMI", the resolution of both the analog video input signal and HDMI input signal can be set.</li> <li>• To watch 1080p/24Hz pictures, use a TV that supports 1080p/24Hz video signals.</li> <li>• When set to "1080p:24Hz", you can enjoy film-like pictures for film sources (in 24 Hz). For video sources and mixed sources, we recommend setting the resolution to "1080p".</li> <li>• It is not possible to convert a 50 Hz signal into 1080p/24Hz. It is output at a resolution of 1080p/50Hz.</li> </ul>
CBL/SAT	*	DVD	*																		
Blu-ray	*	GAME	*																		
AUX	*	MEDIA PLAYER	*																		
iPod/USB		CD	*																		
NETWORK		TV AUDIO	*																		

Setting items	Setting details																				
<b>Progressive Mode</b> Set an appropriate progressive conversion mode for the source video signal. <table border="1"> <tr><td>CBL/SAT</td><td>*</td><td>DVD</td><td>*</td></tr> <tr><td>Blu-ray</td><td>*</td><td>GAME</td><td>*</td></tr> <tr><td>AUX</td><td>*</td><td>MEDIA PLAYER</td><td>*</td></tr> <tr><td>CD</td><td>*</td><td>TV AUDIO</td><td>*</td></tr> </table>	CBL/SAT	*	DVD	*	Blu-ray	*	GAME	*	AUX	*	MEDIA PLAYER	*	CD	*	TV AUDIO	*	<b>Auto</b> : The video signal is automatically detected and the appropriate mode is set. <b>Video</b> : Select mode suitable for video playback. <b>Video and Film</b> : Select mode suitable for video and 30-frame film material playback.  This item can be set when "i/p Scaler" is set to anything other than "Off".				
CBL/SAT	*	DVD	*																		
Blu-ray	*	GAME	*																		
AUX	*	MEDIA PLAYER	*																		
CD	*	TV AUDIO	*																		
<b>Aspect Ratio</b> Set the aspect ratio for the video signals output to the HDMI. <table border="1"> <tr><td>CBL/SAT</td><td>*</td><td>DVD</td><td>*</td></tr> <tr><td>Blu-ray</td><td>*</td><td>GAME</td><td>*</td></tr> <tr><td>AUX</td><td>*</td><td>MEDIA PLAYER</td><td>*</td></tr> <tr><td>iPod/USB</td><td></td><td>CD</td><td>*</td></tr> <tr><td>NETWORK</td><td></td><td>TV AUDIO</td><td>*</td></tr> </table>	CBL/SAT	*	DVD	*	Blu-ray	*	GAME	*	AUX	*	MEDIA PLAYER	*	iPod/USB		CD	*	NETWORK		TV AUDIO	*	<b>16:9</b> : Output at 16:9 aspect ratio. <b>4:3</b> : Output at 4:3 aspect ratio with black bars on the sides of a 16:9 TV screen (except for 480p/576p output).  "Aspect Ratio" can be set when "i/p Scaler" is set to anything other than "Off".
CBL/SAT	*	DVD	*																		
Blu-ray	*	GAME	*																		
AUX	*	MEDIA PLAYER	*																		
iPod/USB		CD	*																		
NETWORK		TV AUDIO	*																		

\* "CBL/SAT", "DVD", "Blu-ray", "GAME", "AUX", "MEDIA PLAYER", "CD" or "TV AUDIO" can be set when "HDMI", "COMP" or "VIDEO" ([page 112, 113](#)) has been assigned.

## On Screen Display

Default settings are underlined.

Select the on-screen display user interface preferences.

Setting items	Setting details
<b>Volume</b> Sets where to display the master volume level.	<u>Bottom</u> : Display at the bottom. <u>Top</u> : Display at the top. <u>Off</u> : Turn display off.  When the master volume display is hard to see when superimposed text (closed captioning) or movie subtitles are present, set to "Top".
<b>Info</b> Displays status of operation temporarily when the sound mode is changed, or input source is switched. You can set whether or not to show each of these status displays.	<u>On</u> : Turn display on. <u>Off</u> : Turn display off.
<b>Now Playing</b> Sets how long each menu is displayed when the input source is "NETWORK", "iPod/USB", or "TUNER".	<u>Always On</u> : Show display continuously. <u>Auto Off</u> : Show display for 30 seconds after operation.

## TV Format

Default settings are underlined.

Set the video signal format to be output for the TV you are using.

Setting items	Setting details
<b>Format</b>	<u>NTSC</u> : Select NTSC output. <u>PAL</u> : Select PAL output.  "Format" can also be set by the following procedure. However, the menu screen is not displayed. <ol style="list-style-type: none"> <li>1. Press and hold the main unit's <b>ZONE2 SOURCE</b> and <b>STATUS</b> for at least 3 seconds.                "&lt; NTSC &gt;" appears on the display.</li> <li>2. Use the main unit's <b>SOURCE SELECT</b> ◀ ▶ and set the video signal format.</li> <li>3. Press the main unit's <b>STATUS</b> to complete the setting.</li> </ol> <div style="background-color: #f08080; border-radius: 5px; padding: 2px; display: inline-block; margin-top: 10px;"><b>NOTE</b></div> When a format other than the video format of the connected TV is set, the picture will not be displayed properly.



Perform settings related to input source playback.

- You do not have to change the settings to use the unit. Make settings when needed.

## Menu operation

**1** Press **MAIN** to switch the zone mode.  
**MAIN** lights.

**2** Press **SETUP**.  
The menu is displayed on the TV screen.

**3** Use  $\Delta$ / $\nabla$  to select the menu to be set or operated.

**4** Press **ENTER** or  $\triangleright$  to enter the setting.

- To return to the previous item, press  $\triangleleft$  or **BACK**.
- Exiting the Menu, press **SETUP** while the menu is displayed.  
The menu display disappears.



## Items that can be set with the “Inputs” procedure

Input Assign ([page 112](#))

Source Rename ([page 114](#))

Hide Sources ([page 114](#))

Source Level ([page 114](#))

Input Select ([page 114](#))

## Important information

### □ About the display of input sources

In this section, the configurable input sources for each item are shown as follows.



### NOTE

Input sources that have been set to “Hide” at “Hide Sources” ([page 114](#)) cannot be selected.

## Input Assign

This unit has certain input sources such as "CBL/SAT" assigned to audio and video connectors by default. By making the default connections, you can simply press an input source select button to play back audio or video from the connected device with ease.

When making connections other than the default settings, you must change settings in this section.

### Examples of "Input Assign" menu screen displays

This screen appears when the "Inputs" – "each input source" – "Input Assign" menu is selected. Use the "Input Assign" menu to change the ② HDMI input connectors, ③ Digital input connectors, ④ Analog input connectors, ⑤ Component input connectors, and ⑥ Video input connectors that are assigned to the ① input sources in default settings.

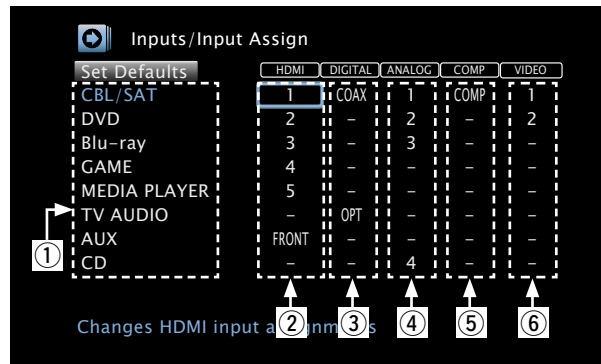

### Input assignments menu operations

- 1** Use  $\Delta$   $\nabla$   $\triangleleft$   $\triangleright$  to move the cursor to the item you want to set, and then press **ENTER**.
- 2** Use  $\triangleleft$   $\triangleright$  to select the input connector to be assigned.
- 3** Press **ENTER** to register the setting.

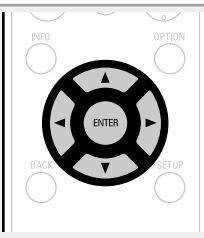

Setting items	Setting details													
<b>HDMI</b> Set this to change the HDMI input connectors assigned to the input sources.	<b>1 / 2 / 3 / 4 / 5 / FRONT</b> : Assign an HDMI input connector to the selected input source. – : Do not assign an HDMI input connector to the selected input source.													
<table border="1"> <tr><td>CBL/SAT</td><td>DVD</td></tr> <tr><td>Blu-ray</td><td>GAME</td></tr> <tr><td>AUX</td><td>MEDIA PLAYER</td></tr> <tr><td>CD</td><td>TV AUDIO</td></tr> </table>	CBL/SAT	DVD	Blu-ray	GAME	AUX	MEDIA PLAYER	CD	TV AUDIO	<ul style="list-style-type: none"> <li>At time of purchase, the settings of the different input sources are as shown below.</li> </ul>					
CBL/SAT	DVD													
Blu-ray	GAME													
AUX	MEDIA PLAYER													
CD	TV AUDIO													
	<table border="1"> <tr><th>Input source</th><th>CBL/SAT</th><th>DVD</th><th>Blu-ray</th><th>GAME</th></tr> <tr><th>Default setting</th><td>1</td><td>2</td><td>3</td><td>4</td></tr> </table>	Input source	CBL/SAT	DVD	Blu-ray	GAME	Default setting	1	2	3	4			
Input source	CBL/SAT	DVD	Blu-ray	GAME										
Default setting	1	2	3	4										
	<table border="1"> <tr><th>Input source</th><th>AUX</th><th>MEDIA PLAYER</th><th>CD</th><th>TV AUDIO</th></tr> <tr><th>Default setting</th><td>FRONT</td><td>5</td><td>–</td><td>–</td></tr> </table>	Input source	AUX	MEDIA PLAYER	CD	TV AUDIO	Default setting	FRONT	5	–	–			
Input source	AUX	MEDIA PLAYER	CD	TV AUDIO										
Default setting	FRONT	5	–	–										
	<ul style="list-style-type: none"> <li>To play the video signal assigned at "HDMI" combined with the audio signal assigned at "Input Assign" – "DIGITAL", select "Digital" at "Input Mode" (<a href="#">page 114</a>).</li> <li>When "HDMI Control" (<a href="#">page 108</a>) is set to "On", HDMI input connector cannot be assigned to "TV AUDIO".</li> </ul>													

Setting items	Setting details																												
<p><b>DIGITAL</b> Set this to change the digital audio input connectors assigned to the input sources.</p> <table border="1"> <tr><td>CBL/SAT</td><td>DVD</td></tr> <tr><td>Blu-ray</td><td>GAME</td></tr> <tr><td>AUX</td><td>MEDIA PLAYER</td></tr> <tr><td>CD</td><td>TV AUDIO</td></tr> </table>	CBL/SAT	DVD	Blu-ray	GAME	AUX	MEDIA PLAYER	CD	TV AUDIO	<p><b>COAX (Coaxial) / OPT (Optical)</b> : Assign a digital input connector to the selected input source. – : Do not assign a digital input connector to the selected input source.</p> <ul style="list-style-type: none"> <li>At time of purchase, the settings of the different input sources are as shown below.</li> </ul> <table border="1"> <tr> <td>Input source</td> <td>CBL/SAT</td> <td>DVD</td> <td>Blu-ray</td> <td>GAME</td> </tr> <tr> <td>Default setting</td> <td>COAX</td> <td>–</td> <td>–</td> <td>–</td> </tr> </table> <table border="1"> <tr> <td>Input source</td> <td>AUX</td> <td>MEDIA PLAYER</td> <td>CD</td> <td>TV AUDIO</td> </tr> <tr> <td>Default setting</td> <td>–</td> <td>–</td> <td>–</td> <td>OPT</td> </tr> </table>	Input source	CBL/SAT	DVD	Blu-ray	GAME	Default setting	COAX	–	–	–	Input source	AUX	MEDIA PLAYER	CD	TV AUDIO	Default setting	–	–	–	OPT
CBL/SAT	DVD																												
Blu-ray	GAME																												
AUX	MEDIA PLAYER																												
CD	TV AUDIO																												
Input source	CBL/SAT	DVD	Blu-ray	GAME																									
Default setting	COAX	–	–	–																									
Input source	AUX	MEDIA PLAYER	CD	TV AUDIO																									
Default setting	–	–	–	OPT																									
<p><b>ANALOG</b> Set this to change the analog audio input connectors assigned to the input sources.</p> <table border="1"> <tr><td>CBL/SAT</td><td>DVD</td></tr> <tr><td>Blu-ray</td><td>GAME</td></tr> <tr><td>AUX</td><td>MEDIA PLAYER</td></tr> <tr><td>CD</td><td>TV AUDIO</td></tr> </table>	CBL/SAT	DVD	Blu-ray	GAME	AUX	MEDIA PLAYER	CD	TV AUDIO	<p><b>1 / 2 / 3 / 4</b> : Assign a analog input connector to the selected input source. – : Do not assign a analog input connector to the selected input source.</p> <ul style="list-style-type: none"> <li>At time of purchase, the settings of the different input sources are as shown below.</li> </ul> <table border="1"> <tr> <td>Input source</td> <td>CBL/SAT</td> <td>DVD</td> <td>Blu-ray</td> <td>GAME</td> </tr> <tr> <td>Default setting</td> <td>1</td> <td>2</td> <td>3</td> <td>–</td> </tr> </table> <table border="1"> <tr> <td>Input source</td> <td>AUX</td> <td>MEDIA PLAYER</td> <td>CD</td> <td>TV AUDIO</td> </tr> <tr> <td>Default setting</td> <td>–</td> <td>–</td> <td>4</td> <td>–</td> </tr> </table>	Input source	CBL/SAT	DVD	Blu-ray	GAME	Default setting	1	2	3	–	Input source	AUX	MEDIA PLAYER	CD	TV AUDIO	Default setting	–	–	4	–
CBL/SAT	DVD																												
Blu-ray	GAME																												
AUX	MEDIA PLAYER																												
CD	TV AUDIO																												
Input source	CBL/SAT	DVD	Blu-ray	GAME																									
Default setting	1	2	3	–																									
Input source	AUX	MEDIA PLAYER	CD	TV AUDIO																									
Default setting	–	–	4	–																									

Setting items	Setting details																												
<p><b>COMP</b> (Component video) Set this to change the component video input connectors assigned to the input sources.</p> <table border="1"> <tr><td>CBL/SAT</td><td>DVD</td></tr> <tr><td>Blu-ray</td><td>GAME</td></tr> <tr><td>AUX</td><td>MEDIA PLAYER</td></tr> <tr><td>CD</td><td>TV AUDIO</td></tr> </table>	CBL/SAT	DVD	Blu-ray	GAME	AUX	MEDIA PLAYER	CD	TV AUDIO	<p><b>COMP</b> : Assign the component video input connector to the selected input source. – : Do not assign a component video input connector to the selected input source.</p> <ul style="list-style-type: none"> <li>At time of purchase, the settings of the different input sources are as shown below.</li> </ul> <table border="1"> <tr> <td>Input source</td> <td>CBL/SAT</td> <td>DVD</td> <td>Blu-ray</td> <td>GAME</td> </tr> <tr> <td>Default setting</td> <td>COMP</td> <td>–</td> <td>–</td> <td>–</td> </tr> </table> <table border="1"> <tr> <td>Input source</td> <td>AUX</td> <td>MEDIA PLAYER</td> <td>CD</td> <td>TV AUDIO</td> </tr> <tr> <td>Default setting</td> <td>–</td> <td>–</td> <td>–</td> <td>–</td> </tr> </table>	Input source	CBL/SAT	DVD	Blu-ray	GAME	Default setting	COMP	–	–	–	Input source	AUX	MEDIA PLAYER	CD	TV AUDIO	Default setting	–	–	–	–
CBL/SAT	DVD																												
Blu-ray	GAME																												
AUX	MEDIA PLAYER																												
CD	TV AUDIO																												
Input source	CBL/SAT	DVD	Blu-ray	GAME																									
Default setting	COMP	–	–	–																									
Input source	AUX	MEDIA PLAYER	CD	TV AUDIO																									
Default setting	–	–	–	–																									
<p><b>VIDEO</b> Set this to change the composite video input connectors assigned to the input sources.</p> <table border="1"> <tr><td>CBL/SAT</td><td>DVD</td></tr> <tr><td>Blu-ray</td><td>GAME</td></tr> <tr><td>AUX</td><td>MEDIA PLAYER</td></tr> <tr><td>CD</td><td>TV AUDIO</td></tr> </table>	CBL/SAT	DVD	Blu-ray	GAME	AUX	MEDIA PLAYER	CD	TV AUDIO	<p><b>1 / 2</b> : Assign the video input connector to the selected input source. – : Do not assign a video input connector to the selected input source.</p> <ul style="list-style-type: none"> <li>At time of purchase, the settings of the different input sources are as shown below.</li> </ul> <table border="1"> <tr> <td>Input source</td> <td>CBL/SAT</td> <td>DVD</td> <td>Blu-ray</td> <td>GAME</td> </tr> <tr> <td>Default setting</td> <td>1</td> <td>2</td> <td>–</td> <td>–</td> </tr> </table> <table border="1"> <tr> <td>Input source</td> <td>AUX</td> <td>MEDIA PLAYER</td> <td>CD</td> <td>TV AUDIO</td> </tr> <tr> <td>Default setting</td> <td>–</td> <td>–</td> <td>–</td> <td>–</td> </tr> </table>	Input source	CBL/SAT	DVD	Blu-ray	GAME	Default setting	1	2	–	–	Input source	AUX	MEDIA PLAYER	CD	TV AUDIO	Default setting	–	–	–	–
CBL/SAT	DVD																												
Blu-ray	GAME																												
AUX	MEDIA PLAYER																												
CD	TV AUDIO																												
Input source	CBL/SAT	DVD	Blu-ray	GAME																									
Default setting	1	2	–	–																									
Input source	AUX	MEDIA PLAYER	CD	TV AUDIO																									
Default setting	–	–	–	–																									

**Set Defaults**  
The “Input Assign” settings are returned to the default settings.

**Reset** : Reset to the defaults.  
**Cancel** : Do not reset to the defaults.

 If you select “Set Defaults” and press **ENTER**, the message “Reset all input assignments to the factory default?” is displayed. Select “Reset” or “Cancel”, and then press **ENTER**.

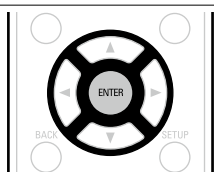



## Source Rename

Change the display name of the selected input source.

This is convenient when the input source name of your device and the input source name of this unit are different. You can change the name to suit your needs. When the renaming is completed, the name is displayed on this unit's display and on the menu screen.

### Setting details

**CBL/SAT / DVD / Blu-ray / GAME / AUX / MEDIA PLAYER / CD / TV AUDIO** : Change the display name of the selected input source.

- Up to 12 characters can be input.
- For character input, see [page 99](#).

**Set Defaults** : The "Source Rename" settings are returned to the default settings.

- **Reset** : Reset to the defaults.
- **Cancel** : Do not reset to the defaults.

 If you select "Set Defaults" and press **ENTER**, the message "Reset all source names to the factory defaults?" is displayed. Select "Reset" or "Cancel", and then press **ENTER**.

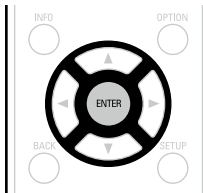

## Hide Sources

**Default settings are underlined.**

Remove from the display input sources that are not used.

### Setting details

**CBL/SAT / DVD / Blu-ray / GAME / AUX / MEDIA PLAYER / iPod/USB / CD / TUNER / Favorites / Internet Radio / Media Server / Pandora / SiriusXM / Spotify / Flickr / TV AUDIO** : Select input source that is not used.

- **Show** : Use this source.
- **Hide** : Do not use this source.

### NOTE

- Input sources being used in the various zones cannot be deleted.
- Input sources set to "Hide" cannot be selected using the input source select button.

## Source Level

**Default settings are underlined.**

- This function corrects the playback level of the selected input source's audio input.
- Make this setting if there are differences in the input volume levels between the different sources.

### Setting details



**-12dB – +12dB (0dB)**

## Input Select

**Default settings are underlined.**

Set the audio input mode and decode mode of each input source.

The input modes available for selection may vary depending on the input source.

Setting items	Setting details
<b>Input Mode</b> Set the audio input modes for the different input sources. It is normally recommended to set the audio input mode to "Auto".	<b>Auto</b> : Automatically detect input signal and perform playback. <b>HDMI</b> : Play only signals from HDMI input. <b>Digital</b> : Play only signals from digital input. <b>Analog</b> : Play only signals from analog input.  <ul style="list-style-type: none"> <li>• "Digital" can be set for input sources for which "DIGITAL" is assigned at "Input Assign" (<a href="#">page 113</a>).</li> <li>• When digital signals are properly input, the <b>DIG.</b> indicator lights on the display. If the <b>DIG.</b> indicator does not light, check "Input Assign" (<a href="#">page 113</a>) and the connections.</li> <li>• If "HDMI Control" is set to "On" and a TV compatible with the ARC is connected via the HDMI MONITOR connectors, the input mode whose input source is "TV AUDIO" is fixed to ARC.</li> </ul>
<b>Decode Mode</b> Set the audio decode mode for input source.	<b>Auto</b> : Detect type of digital input signal and decode and play automatically. <b>PCM</b> : Decode and play only PCM input signals. <b>DTS</b> : Decode and play only DTS input signals.  <ul style="list-style-type: none"> <li>• This item can be set for input sources for which "DIGITAL" is assigned at "Input Assign" (<a href="#">page 113</a>).</li> <li>• Normally set this mode to "Auto". Set "PCM" and "DTS" when inputting the corresponding input signal.</li> </ul>

CBL/SAT	DVD
Blu-ray	GAME
AUX	MEDIA PLAYER
CD	TV AUDIO



Set when changing Audyssey® Setup settings.

- If you change the speaker settings after performing Audyssey® Setup, it will not be possible to set Audyssey MultEQ®, Audyssey Dynamic EQ® and Audyssey Dynamic Volume® (☞ [page 104, 105](#)).
- Can be used without changing the settings. Please set if necessary.

## Menu operation

**1** Press **MAIN** to switch the zone mode.  
**MAIN** lights.

**2** Press **SETUP**.  
The menu is displayed on the TV screen.

**3** Use  $\Delta$ / $\nabla$  to select the menu to be set or operated.

**4** Press **ENTER** or  $\blacktriangleright$  to enter the setting.

- To return to the previous item, press  $\blacktriangleleft$  or **BACK**.
- Exiting the Menu, press **SETUP** while the menu is displayed.  
The menu display disappears.

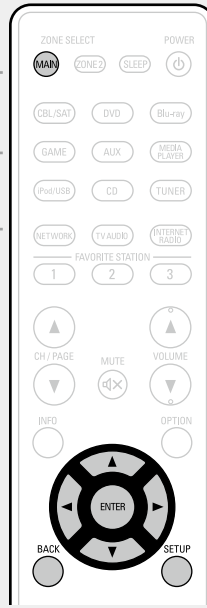

## Items that can be set with the “Speakers” procedure

Audyssey® Setup (☞ [page 21, 86](#))



Manual Setup (☞ [page 116](#))

## Manual Setup



Default settings are underlined.



Perform when setting the speakers manually or when changing settings made in Audyssey® Setup.

- If you change the speaker settings after performing Audyssey® Setup, it will not be possible to select Audyssey MultEQ®, Audyssey Dynamic EQ® and Audyssey Dynamic Volume® ([page 104, 105](#)).
- “Manual Setup” can be used without changing the settings. Please set if necessary.

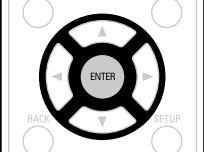
Setting items	Setting details
<b>Amp Assign</b> Select power amplifier usage method to match your speaker system.	<b>Assign Mode</b> : Set the assignment mode. <ul style="list-style-type: none"> <li>• <b>Surround Back</b> : Setting for 7.1-channel playback using surround back speakers.</li> <li>• <b>ZONE2</b> : Setting to assign the unit’s built-in power amplifier for ZONE2 and output the audio in stereo.</li> <li>• <b>Front Height</b> : Setting for 7.1-channel playback using front height speakers.</li> </ul>
<b>Speaker Config.</b> Indicate speaker presence and select speaker size categories based on bass reproduction capability.	<b>Front</b> : Set the front speaker size. <ul style="list-style-type: none"> <li>• <b>Large</b> : Use a large speaker that can adequately play back very low bass frequencies.</li> <li>• <b>Small</b> : Use a small speaker that has inadequate playback capacity for very low bass frequencies. Note that for most multi-channel speakers, this is the best choice.</li> </ul>  <ul style="list-style-type: none"> <li>• When “Subwoofer” is set to “No”, “Front” is automatically set to “Large”.</li> <li>• When “Front” is set to “Small”, “Center”, “Surround”, “Surr. Back” and “Front Height” can not be set to “Large”.</li> </ul>
<p><b>NOTE</b></p> Do not use the outward shape of the speaker to determine selection of a “Large” or “Small” speaker. Instead, use the frequencies set in “Crossovers” ( <a href="#">page 118</a> ) as the standard for determining bass reproduction capability.	<b>Center</b> : Set the presence and size of the center speaker. <ul style="list-style-type: none"> <li>• <b>Large</b> : Use a large speaker that can adequately play back very low bass frequencies.</li> <li>• <b>Small</b> : Use a small speaker that has inadequate playback capacity for very low bass frequencies. Note that this is almost always the best choice.</li> <li>• <b>None</b> : Select when a center speaker is not connected.</li> </ul>  “Large” is not displayed when “Front” is set to “Small”.
	<b>Subwoofer</b> : Set the presence of a subwoofer. <ul style="list-style-type: none"> <li>• <b>Yes</b> : Use a subwoofer.</li> <li>• <b>No</b> : Select when a subwoofer is not connected.</li> </ul>  When “Front” is set to “Small”, “Subwoofer” is automatically set to “Yes”.

Setting items	Setting details
<b>Speaker Config.</b> (Continued)	<b>Surround</b> : Set the presence and size of the surround speakers. <ul style="list-style-type: none"> <li>• <b>Large</b> : Use a large speaker that can adequately play back very low bass frequencies.</li> <li>• <b>Small</b> : Use a small speaker that has inadequate playback capacity for very low bass frequencies. Note that this is almost always the best choice.</li> <li>• <b>None</b> : Select when the surround speakers are not connected.</li> </ul>  <ul style="list-style-type: none"> <li>• When “Surround” is set to “Large”, “Surr. Back” and “Front Height” can be set to “Large”.</li> <li>• When “Surround” is set to “None”, “Surr. Back” and “Front Height” are automatically set to “None”.</li> </ul>
	<b>Surr. Back</b> : Set the presence, size and number of surround back speakers. <ul style="list-style-type: none"> <li>• <b>Large</b> : Use a large speaker that can adequately play back very low bass frequencies.</li> <li>• <b>Small</b> : Use a small speaker that has inadequate playback capacity for very low bass frequencies. Note that this is almost always the best choice.</li> <li>• <b>None</b> : Select when the surround back speakers are not connected.</li> </ul> <ul style="list-style-type: none"> <li>• <b>2spkr</b> : Use two surround back speakers.</li> <li>• <b>1spkr</b> : Use only one surround back speaker. When you select this setting, connect the surround back speaker to the left (L) channel.</li> </ul>
	<p><b>NOTE</b></p> When “Assign Mode” setting ( <a href="#">page 116</a> ) is “Surround Back”, you can make the “Surr. Back” setting.
	<b>Front Height</b> : Set the presence and size of the front height speakers. <ul style="list-style-type: none"> <li>• <b>Large</b> : Use a large speaker that can adequately play back very low bass frequencies.</li> <li>• <b>Small</b> : Use a small speaker that has inadequate playback capacity for very low bass frequencies. Note that this is almost always the best choice.</li> <li>• <b>None</b> : Select when the front height speakers are not connected.</li> </ul>
	<p><b>NOTE</b></p> When “Assign Mode” setting ( <a href="#">page 116</a> ) is “Front Height”, you can make the “Front Height” setting.

Setting items	Setting details
<b>Distances</b> Set distance from listening position to speakers. Measure beforehand the distance from the listening position to each speaker.	<p><b>Unit</b> : Set the unit of distance.</p> <ul style="list-style-type: none"> <li>• <b>Feet / Meters</b></li> </ul> <p><b>Step</b> : Set the minimum variable width of the distance.</p> <ul style="list-style-type: none"> <li>• <b>1ft / 0.1ft</b></li> <li>• <b>0.1m / 0.01m</b></li> </ul> <p><b>Set Defaults</b> : The “Distances” settings are returned to the default settings.</p> <ul style="list-style-type: none"> <li>• <b>Reset</b> : Reset to the defaults.</li> <li>• <b>Cancel</b> : Do not reset to the defaults.</li> </ul> <p> When you select “Set Defaults” and press <b>ENTER</b>, the “Resets all of the distance settings to the factory defaults?” prompt is displayed. Select either “Reset” or “Cancel”, and press <b>ENTER</b>.</p>  <p><b>Front L / Front R / F. Height L / F. Height R / Center / Subwoofer / Surround L / Surround R / Surr. Back L* / Surr. Back R*</b> : Select speaker for distance setting.</p> <p>* When the “Speaker Config.” – “Surr. Back” setting (<a href="#">page 116</a>) is set to “1spkr”, “Surr. Back” is displayed.</p> <ul style="list-style-type: none"> <li>• <b>0.0ft – 60.0ft / 0.00m – 18.00m</b> : Set the distance.</li> </ul> <p> The speakers that can be selected differ depending on the “Amp Assign” (<a href="#">page 116</a>) and “Speaker Config.” (<a href="#">page 116</a>) settings.</p> <ul style="list-style-type: none"> <li>• Default settings :            Front L / Front R / F. Height L / F. Height R / Center / Subwoofer : 12.0 ft (3.60 m)            Surround L / Surround R / Surr. Back L / Surr. Back R : 10.0 ft (3.00 m)</li> <li>• Set the difference in the distance between the speakers to less than 20.0 ft (6.00 m).</li> </ul> <p><b>NOTE</b></p> <p>“Distances” cannot be set for speakers with “Speaker Config.” (<a href="#">page 116</a>) set to “None”.</p>

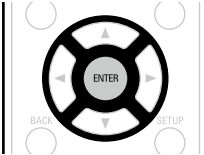
Setting items	Setting details
<b>Levels</b> Set the volume of the test tone to be the same when it is output from each speaker.	<p><b>Test Tone Start</b> : Output test tone.</p> <ul style="list-style-type: none"> <li>• <b>Front L / F. Height L / Center / F. Height R / Front R / Surround R / Surr. Back R* / Surr. Back L* / Surround L / Subwoofer</b> : A test tone is output from the selected speaker. While listening to the test tone, adjust the volume output from the selected speaker.</li> <li>* When the “Speaker Config.” – “Surr. Back” setting (<a href="#">page 116</a>) is set to “1spkr”, “Surr. Back” is displayed.</li> </ul> <ul style="list-style-type: none"> <li>• <b>-12.0dB – +12.0dB (0.0dB)</b> : Adjust the volume.</li> </ul> <p> When “Levels” is adjusted, the adjusted values are set for all the sound modes.</p> <p><b>NOTE</b></p> <ul style="list-style-type: none"> <li>• “Levels” cannot be set for speakers with “Speaker Config.” (<a href="#">page 116</a>) set to “None”.</li> <li>• When headphones are connected to the PHONES connector on this unit, you cannot set “Levels”.</li> </ul> <p><b>Set Defaults</b> : The “Levels” settings are returned to the default settings.</p> <ul style="list-style-type: none"> <li>• <b>Reset</b> : Reset to the defaults.</li> <li>• <b>Cancel</b> : Do not reset to the defaults.</li> </ul> <p> When you select “Set Defaults” and press <b>ENTER</b>, the “Reset all of the channel level settings to the factory defaults?” prompt is displayed. Select either “Reset” or “Cancel”, and press <b>ENTER</b>.</p> 

Setting items	Setting details
<b>Crossovers</b> Set the maximum frequency of the bass signal output from each channel to the subwoofer. Set the Crossover Frequency to suit the bass reproduction capability of the speaker being used.	<p><b>Speaker Selection</b> : Selects how to set the crossover frequency. See the speaker manual for information concerning speaker crossover frequency.</p> <ul style="list-style-type: none"> <li>• <b>All</b> : Selects the crossover point of all speakers at the same time.</li> <li>• <b>Individual</b> : Selects the crossover points for each speaker individually.</li> </ul> <p>The following settings can be set when the "Speaker Selection" setting is set to "Individual".</p> <ul style="list-style-type: none"> <li>• <b>Front / Center / Surround / Surr. Back / Front Height</b> : Select speaker for setting of crossover frequency.</li> <li>• <b>40Hz / 60Hz / 80Hz / 90Hz / 100Hz / 110Hz / 120Hz / 150Hz / 200Hz / 250Hz</b> : Set the crossover frequency.</li> </ul> <p></p> <ul style="list-style-type: none"> <li>• "Crossovers" can be set when the "Bass" – "Subwoofer Mode" (<a href="#">page 118</a>) setting is "LFE+Main", or when you have a speaker that is set to "Small".</li> <li>• The default crossover frequency is "80Hz", which will work best with the widest variety of speakers. When using very small speakers, however, you can choose a higher setting based on the specified frequency response of the speakers. If the speaker has a specified frequency response of 120 Hz – 20 kHz (as an example), then choose the 120 Hz crossover frequency.</li> <li>• For speakers set to "Small", low frequency content below the crossover frequency is attenuated to the speakers and the low bass content is then re-delivered to the subwoofer, or the front (L/R) speakers if they have been set to Large.</li> <li>• The speakers that can be set when "Individual" is selected differ depending on to the "Subwoofer Mode" setting (<a href="#">page 118</a>).             <ul style="list-style-type: none"> <li>• When "LFE" is selected, speakers set to "Small" at "Speaker Config." can be set. If the speakers are set to "Large", "Full Band" is displayed and the setting cannot be made.</li> <li>• If set to "LFE+Main", this setting can be made regardless of the speaker size.</li> </ul> </li> </ul>

Setting items	Setting details
<b>Bass</b> Set subwoofer and LFE signal range playback.	<p><b>Subwoofer Mode</b> : Select low range signals to be reproduced by subwoofer.</p> <ul style="list-style-type: none"> <li>• <b>LFE</b> : The low range signal of the channel set to "Small" speaker size is added to the LFE signal output from the subwoofer.</li> <li>• <b>LFE+Main</b> : The low range signal of all channels is added to the LFE signal output from the subwoofer. This is usually the best setting for most systems.</li> </ul> <p></p> <ul style="list-style-type: none"> <li>• "Subwoofer Mode" can be set when "Speaker Config." – "Subwoofer" (<a href="#">page 116</a>) is set to other than "No".</li> <li>• Play music or a movie source and select the mode offering the strongest bass.</li> <li>• Select "LFE+Main" if you want the bass signals to always be produced from the subwoofer.</li> </ul> <p><b>NOTE</b></p> <p>If "Front" and "Center" for "Speaker Config." are set to "Large", and "Subwoofer Mode" is set to "LFE", no sound may be output from the subwoofers, depending on the input signal or selected sound mode.</p> <p><b>LPF for LFE</b> : Set LFE signal playback range. Set this when you want to change the playback frequency (low pass filter point) of the subwoofer.</p> <ul style="list-style-type: none"> <li>• <b>80Hz / 90Hz / 100Hz / 110Hz / 120Hz / 150Hz / 200Hz / 250Hz</b></li> </ul>



To use this unit by connecting it to a home network (LAN), you must configure network settings. If you set up your home network (LAN) via DHCP, set "DHCP" to "On" (use the default setting). This allows this unit to use your home network (LAN).

If you assign an IP address for each device, you must use the "IP Address" setting to assign an IP address to this unit and enter the information about your home network (LAN) such as the gateway address and subnet mask.

## Menu operation

**1** Press **MAIN** to switch the zone mode.  
**MAIN** lights.

**2** Press **SETUP**.  
The menu is displayed on the TV screen.

**3** Use  $\Delta$ / $\nabla$  to select the menu to be set or operated.

**4** Press **ENTER** or  $\blacktriangleright$  to enter the setting.

- To return to the previous item, press  $\blacktriangleleft$  or **BACK**.
- Exiting the Menu, press **SETUP** while the menu is displayed.  
The menu display disappears.



## Items that can be set with the "Network" procedure

Information (👉 [page 120](#))

IP Control (👉 [page 120](#))

Friendly Name (👉 [page 120](#))

Settings (👉 [page 121](#))

Diagnostics (👉 [page 122](#))

## Information

Display network information.

### Setting details

#### Friendly Name / DHCP On or Off / IP Address / MAC Address

 MAC Address is required to make a vTuner account.

## IP Control

Default settings are underlined.

Enables network communication in standby power mode.

### Setting details

**Off In Standby** : Suspend network function during standby.

**Always On** : Network is on during standby. Main unit operable with a network compatible controller.

 Set to "Always On" when using the web control function.

### NOTE

When "IP Control" is set to "Always On", it consumes more standby power.

## Friendly Name

The Friendly Name is the name of this unit displayed on the network. You can change the Friendly Name according to your preferences.

### Setting items

#### Edit Name

Edits Friendly Name.

#### Set Defaults

Restores Friendly Name, which you had changed, to the default setting.

### Setting details

- The default Friendly Name on first use is "Denon AVR-E400".
- Up to 63 characters can be input.
- For character input, see [page 99](#).

**Reset** : Reset to the defaults.

**Cancel** : Do not reset to the defaults.

 When you select "Set Defaults" and press **ENTER**, the "Reset the friendly name back to the factory default?" prompt is displayed. Select either "Reset" or "Cancel", and press **ENTER**.

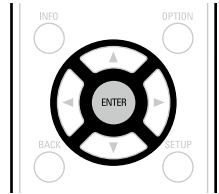

## Settings

Make settings for wired LAN.

Only set "Settings" when connecting to a network without a DHCP function.

### Setting details

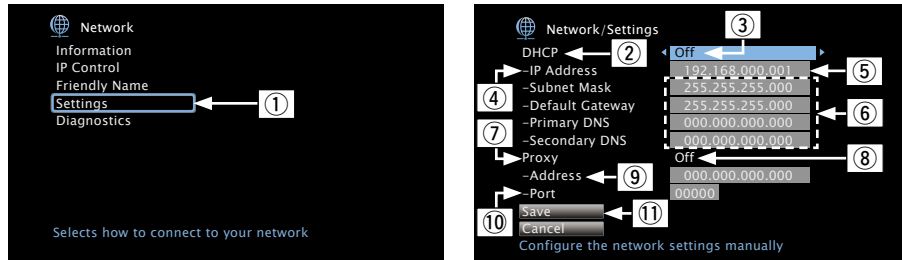

① On the menu, select "Network" – "Settings" and press **ENTER**.

② Use  $\Delta \nabla$  to select "DHCP", then press **ENTER**.

③ Use  $\triangleleft \triangleright$  to select "Off", then press **ENTER**.

④ Use  $\Delta \nabla$  to select "IP Address", then press **ENTER**.

• **IP Address** : Set the IP address within the ranges shown below.

The Network Audio function cannot be used if other IP addresses are set.

CLASS A: 10.0.0.1 – 10.255.255.254

CLASS B: 172.16.0.1 – 172.31.255.254

CLASS C: 192.168.0.1 – 192.168.255.254

⑤ Use  $\Delta \nabla \triangleleft \triangleright$  to input the address and press **ENTER**.

⑥ Use  $\Delta \nabla$  to select setting item, then press **ENTER**.

• **Subnet Mask** : When connecting an xDSL modem or terminal adapter directly to this unit, input the subnet mask indicated in the documentation supplied by your provider. Normally input 255.255.255.0.

• **Default Gateway** : When connected to a gateway (router), input its IP address.

• **Primary DNS, Secondary DNS** : If there is only one DNS address indicated in the documentation supplied by your provider, input it at "Primary DNS". If two or more DNS are provided by your provider, enter both "Primary DNS" and "Secondary DNS".

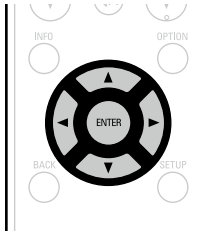

### Setting details

⑦ Use  $\Delta \nabla$  to select "Proxy" and press **ENTER**.

• **Proxy** : Make this setting when connecting to the Internet via a proxy server.

Make the proxy settings only when you connect to the Internet via a proxy server that is on your internal network or provided by your provider, etc.

⑧ Use  $\triangleleft \triangleright$  to select "On(Address)" or "On(Name)", and then press **ENTER**.

**On(Address)** : Select when inputting by address.

**On(Name)** : Select when inputting by domain name. Up to 38 characters can be input.

⑨ Press  $\nabla$  to select "Address" or "Name", then press **ENTER**.

When "Address" is selected in step ⑧ : Use  $\Delta \nabla \triangleleft \triangleright$  to enter the proxy server address, and press **ENTER**.

When "Name" is selected in step ⑧ : Use the software keyboard ([page 99](#)) to enter the domain name, and select **OK**.

• For character input, see [page 99](#).

⑩ Press  $\nabla$  to select "Port", then press **ENTER**. Use  $\Delta \nabla \triangleleft \triangleright$  to input the proxy server port number and press **ENTER**.

Setup is complete.

⑪ Press  $\nabla$  to select "Save", then press **ENTER**.

The display returns to the original screen.



• If you are using a broadband router (DHCP function), there is no need to make the settings at "IP Address" and "Proxy", since the DHCP function is set to "On" in this unit's default settings.

• If this unit is connected to a network without the DHCP function, the network settings must be made. In this case, some knowledge of networks is required. For details, consult a network administrator.

• If you cannot connect to the Internet, recheck the connections and settings ([page 19](#)).

• If you do not understand about Internet connection, contact your ISP (Internet Service Provider) or the store from which you purchased your computer.

• When you want to cancel the setting during IP address input, select "Cancel", then press **ENTER**.



## Diagnostics

Used to check the network connection.

Setting items	Setting details
<b>Physical Connection</b> Checks the physical LAN port connection.	<b>OK</b> : Connected. <b>Error</b> : The LAN cable is not connected. Check the connection.
<b>Router Access</b> Checks the connection from this unit to the router.	<b>OK</b> : Accessed. <b>Error</b> : Failed to communicate with the router. Check the router settings.
<b>Internet Access</b> Checks whether this unit has access to the Internet (WAN).	<b>OK</b> : Connected. <b>Error</b> : Failed to connect to the Internet. Check the Internet connection environment or router settings.



Make various other settings.

## Menu operation

**1** Press **MAIN** to switch the zone mode.  
**MAIN** lights.

**2** Press **SETUP**.  
The menu is displayed on the TV screen.

**3** Use  $\Delta$ / $\nabla$  to select the menu to be set or operated.

**4** Press **ENTER** or  $\triangleright$  to enter the setting.

- To return to the previous item, press  $\triangleleft$  or **BACK**.
- Exiting the Menu, press **SETUP** while the menu is displayed.  
The menu display disappears.

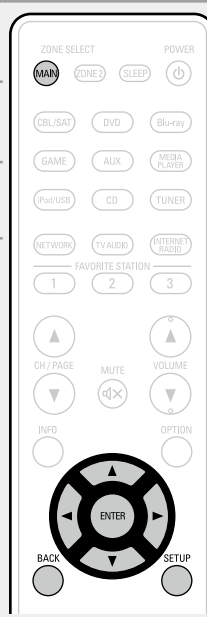

## Items that can be set with the "General" procedure

Language ([page 124](#))

ZONE2 Setup ([page 124](#))

Zone Rename ([page 124](#))

Quick Select Names ([page 125](#))

Auto Standby ([page 125](#))

Front Display ([page 125](#))

Information ([page 126](#))

Usage Data ([page 127](#))

Firmware ([page 127](#))

Setup Lock ([page 128](#))

## Language

Default settings are underlined.

Set the language for display on the menu screen.

### Setting details

#### English / Français / Español



“Language” can also be set by the following procedure. However, the menu screen is not displayed. Following the display content to make the setting.

1. Press and hold the main unit's **ZONE2 SOURCE** and **STATUS** for at least 3 seconds.  
“< NTSC >” appears on the display.
2. Press the main unit's **DIMMER** and set “< ENGLISH >”.
3. Use the main unit's **SOURCE SELECT** ◀ ▶ and set the language.
4. Press the main unit's **STATUS** to complete the setting.

## ZONE2 Setup

Default settings are underlined.

Set the audio to play back with multi-zone (ZONE2).

Setting items	Setting details
<b>Lch Level</b> Adjust the left channel output level.	<b>-12dB – +12dB (0dB)</b>
<b>Rch Level</b> Adjust the right channel output level.	<b>-12dB – +12dB (0dB)</b>
<b>Volume Level</b> Set the volume output level.	<b>Variable</b> : Volume adjustment is enabled by main unit and remote control unit. <b>1 – 98 (-79dB – 18dB)</b> : The volume is adjusted to the set level.
<b>Volume Limit</b> Make a setting for maximum volume.	<b>60 (-20dB) / 70 (-10dB) / 80 (0dB)</b> <b>Off</b> : Do not set a maximum volume. This is displayed from -79 dB to 18 dB when “Scale” (page 104) is set to “-79.5dB – 18.0dB”.

Setting items	Setting details
<b>Power On Volume</b> Define the volume setting that is active when the power is turned on.	<b>Last</b> : Use the memorized setting from the last session. <b>Mute</b> : Always mute when power is turned on. <b>1 – 98 (-79dB – 18dB)</b> : The volume is adjusted to the set level. This is displayed from -79 dB to 18 dB when “Scale” (page 104) is set to “-79.5dB – 18.0dB”.
<b>Mute Level</b> Set the amount of attenuation when muting is on.	<b>Full</b> : The sound is muted entirely. <b>-40dB</b> : The sound is attenuated by 40 dB down. <b>-20dB</b> : The sound is attenuated by 20 dB down.

## Zone Rename

Change the display title of each zone to one you prefer.

### Setting details

#### MAIN ZONE / ZONE2

- Up to 10 characters can be input.
- For character input, see [page 99](#).

**Set Defaults** : The input source name is returned to the default setting.

- **Reset** : Reset to the defaults.
- **Cancel** : Do not reset to the defaults.

If you select “Set Defaults” and press **ENTER**, the message “Reset all zone names to the factory defaults?” is displayed. Select “Reset” or “Cancel”, and then press **ENTER**.

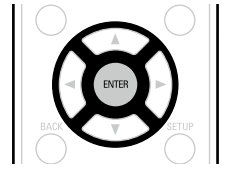

## Quick Select Names

Change the "Quick Select" display title to one you prefer.

### Setting details

#### Quick Select 1 / Quick Select 2 / Quick Select 3 / Quick Select 4

- Up to 16 characters can be input.
- For character input, see [page 99](#).

**Set Defaults** : The input source name is returned to the default setting.

- **Reset** : Reset to the defaults.
- **Cancel** : Do not reset to the defaults.

 If you select "Set Defaults" and press **ENTER**, the message "Reset all Quick Select names to the factory defaults?" is displayed. Select "Reset" or "Cancel", and then press **ENTER**.

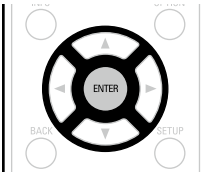

## Auto Standby

**Default settings are underlined.**

When you do not perform any operation on this unit with no audio or video input for a specified time, this unit automatically enters the standby mode. Before it enters the standby mode, "Auto Standby" is displayed on the display of this unit and the menu screen.

### Setting details

- 60 min** : The unit goes into standby after 60 minutes.
- 30 min** : The unit goes into standby after 30 minutes.
- Off** : The unit does not go into standby automatically.

## Front Display

**Default settings are underlined.**

Makes settings related to the display on this unit.

Setting items	Setting details
<b>Dimmer</b> Adjust the display brightness of this unit.	<p><b>Bright</b> : Normal display brightness.  <b>Dim</b> : Reduced display brightness.  <b>Dark</b> : Very low display brightness.  <b>Off</b> : Turns the display off.</p> <p> Buttons on the main unit can be used for operations. Each time <b>DIMMER</b> is pressed, the setting is changed as shown below.</p> <div style="text-align: center;"> <pre>           graph LR             Bright --&gt; Dim             Dim --&gt; Dark             Dark --&gt; Off             Off --&gt; Bright           </pre> </div> <p><b>NOTE</b>            When "Dimmer" is set to "Off", the display turns off and appears as if there is no electricity.</p>

# Information

Show information about receiver settings, input signals, etc.

Items	Setting details				
<b>Audio</b> Show information about audio input signals.	<p><b>Sound Mode</b> : The currently set surround mode.  <b>Input Signal</b> : The input signal type.  <b>Format</b> : The number of input signal channels (presence of front, surround, LFE).  <b>Sample Rate</b> : The input signal's sampling frequency.  <b>Offset</b> : The dialogue normalization correction value.  <b>Flag</b> : This is displayed when inputting signals including a surround back channel. "MATRIX" is displayed with Dolby Digital EX and DTS-ES Matrix signals, "DISCRETE" with DTS-ES Discrete signals.</p> <table border="1" style="width: 100%;"> <thead> <tr> <th>Dialogue normalization function</th> </tr> </thead> <tbody> <tr> <td>                     This function is automatically activated when playing Dolby Digital, Dolby Digital Plus, Dolby TrueHD, DTS and DTS-HD sources. It automatically corrects the standard signal level for individual program sources.                      The correction value can be checked using the <b>STATUS</b> on the main unit.                 </td> </tr> <tr> <td style="text-align: center;"> <div style="border: 1px solid black; padding: 5px; width: fit-content; margin: 0 auto;">Offset: - 4dB</div> </td> </tr> <tr> <td>                     The figure is the corrected value. This cannot be changed.                 </td> </tr> </tbody> </table>	Dialogue normalization function	This function is automatically activated when playing Dolby Digital, Dolby Digital Plus, Dolby TrueHD, DTS and DTS-HD sources. It automatically corrects the standard signal level for individual program sources. The correction value can be checked using the <b>STATUS</b> on the main unit.	<div style="border: 1px solid black; padding: 5px; width: fit-content; margin: 0 auto;">Offset: - 4dB</div>	The figure is the corrected value. This cannot be changed.
Dialogue normalization function					
This function is automatically activated when playing Dolby Digital, Dolby Digital Plus, Dolby TrueHD, DTS and DTS-HD sources. It automatically corrects the standard signal level for individual program sources. The correction value can be checked using the <b>STATUS</b> on the main unit.					
<div style="border: 1px solid black; padding: 5px; width: fit-content; margin: 0 auto;">Offset: - 4dB</div>					
The figure is the corrected value. This cannot be changed.					
<b>Video</b> Show information about HDMI input/output signals and HDMI monitors.	<p><b>HDMI Signal Info.</b></p> <ul style="list-style-type: none"> <li>• Resolution / Color Space / Pixel Depth</li> </ul> <p><b>HDMI Monitor</b></p> <ul style="list-style-type: none"> <li>• Interface / Resolutions</li> </ul>				
<b>ZONE</b> Show information about current settings.	<p><b>MAIN ZONE</b> : This item shows information about settings for MAIN ZONE. The information displayed differs according to the input source.</p> <ul style="list-style-type: none"> <li>• ZONE Name / Select Source / Name / Sound Mode / Input Mode / Decode Mode / HDMI / Digital / Analog / Component / Video / Video Select / Video Mode / Content Type / Video Conversion / i/p Scaler / Resolution / Progressive Mode / Aspect Ratio etc.</li> </ul> <p><b>ZONE2</b> : This item shows information about settings for ZONE2.</p> <ul style="list-style-type: none"> <li>• ZONE Name / Power / Select Source / Volume Level</li> </ul>				
<b>Firmware</b>	<p><b>Version</b> : Displays information for the current firmware.</p>				
<b>Notifications</b> Selects notification message preferences.	<p><b>Notification Alerts</b></p> <ul style="list-style-type: none"> <li>• <b>On</b> : Displays notification messages from Denon in the popup menu.</li> <li>• <b>Off</b> : Does not display notification messages from Denon in the popup menu.</li> </ul>				



Press **INFO** to display current source name, volume, sound mode name, and other information at the bottom of the screen.

## Examples of screen display

- Status display screen  
 When the input source is switched.

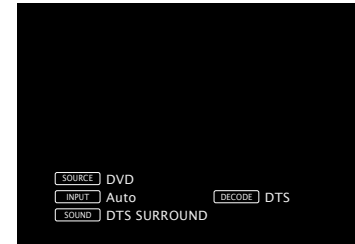

When the volume is adjusted.

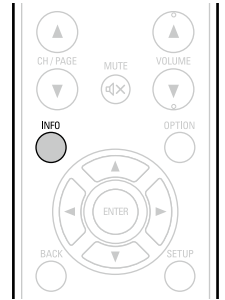
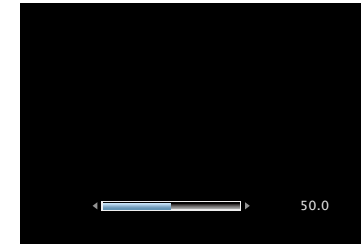

Status display: The operating status appears briefly on the screen when the input source is switched or the volume is changed.

### NOTE

The status display screen cannot be displayed at a computer's resolution (e.g. VGA) or while certain 3D video contents is being played.

## Usage Data

To help us improve our products and customer service, Denon collects anonymous information about how you use your AV receiver (such as frequently used input sources and sound modes and speaker settings). Denon will never provide any information we collect to third parties.

### Setting details

**Yes** : Provide Denon with information about how you use this unit via the network.

**No** : Do not provide Denon with information about how you use this unit via the network.

## Firmware

Set whether or not to check for firmware update, update the firmware, and display update and upgrade notifications.

Setting items	Setting details												
<p><b>Update</b> Update the firmware of the receiver.</p> <p><b>NOTE</b> In cases where it is not possible to connect to the network after doing a firmware update, connect to the network again using "Network" (<a href="#">page 119</a>).</p>	<p><b>Check for Update</b> : Check for firmware updates. You can also check approximately how long it will take to complete an update.</p> <p><b>Update Start</b> : Execute the update process.</p> <p>When updating starts, the power indicator becomes red and the menu screen is shut down. The amount of update time which has elapsed is displayed.</p> <p>When updating is complete, the power indicator becomes green and normal status is resumed.</p> <ul style="list-style-type: none"> <li>If updating fails, the set automatically retries, but if updating is still not possible, one of the messages shown below is displayed. If the display reads as shown below, check the settings and network environment, then update again.</li> </ul> <table border="1"> <thead> <tr> <th>Display</th> <th>Description</th> </tr> </thead> <tbody> <tr> <td><b>Updating fail</b></td> <td>Updating failed.</td> </tr> <tr> <td><b>Login failed</b></td> <td>Failure to log into server.</td> </tr> <tr> <td><b>Server is busy</b></td> <td>Server is busy. Wait a while then try again.</td> </tr> <tr> <td><b>Connection fail</b></td> <td>Failure in connecting to server.</td> </tr> <tr> <td><b>Download fail</b></td> <td>Downloading of the firmware has failed.</td> </tr> </tbody> </table>	Display	Description	<b>Updating fail</b>	Updating failed.	<b>Login failed</b>	Failure to log into server.	<b>Server is busy</b>	Server is busy. Wait a while then try again.	<b>Connection fail</b>	Failure in connecting to server.	<b>Download fail</b>	Downloading of the firmware has failed.
Display	Description												
<b>Updating fail</b>	Updating failed.												
<b>Login failed</b>	Failure to log into server.												
<b>Server is busy</b>	Server is busy. Wait a while then try again.												
<b>Connection fail</b>	Failure in connecting to server.												
<b>Download fail</b>	Downloading of the firmware has failed.												

### Setting items

#### Notifications

Displays a notification message on this unit's menu screen when the latest firmware is released with "Update".

Display a notification message on this unit's menu screen when downloadable firmware is released with "Add New Feature".

### Setting details

**Update** : The notification message is displayed for about 20 seconds when the power is turned on. Connect to broadband Internet ([page 19](#)) when using this function.

- **On** : Display update message.
- **Off** : Do not display update message.



- When you press **ENTER** during display of the notification message, the "Check for Update" screen is displayed (Refer to [page 127](#) for more information on "Update").

- Press **BACK** to erase the notification message.

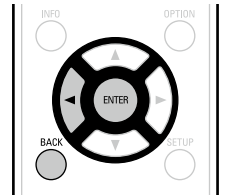

**Upgrade** : The notification message is displayed for about 20 seconds when the power is turned on. Connect to broadband Internet ([page 19](#)) when using this function.

- **On** : Display upgrade message.
- **Off** : Do not display upgrade message.



- When you press **ENTER** during display of the notification message, the "Add New Feature" screen is displayed (Refer to [page 128](#) for more information on "Add New Feature").

- Press **BACK** to erase the notification message.

Setting items	Setting details
<p><b>Add New Feature</b> Display new features that can be downloaded to this unit and perform an upgrade.</p> <p><b>NOTE</b> In cases where it is not possible to connect to the network after adding a new function, connect to the network again using "Network" (<a href="#">page 119</a>).</p>	<p><b>Upgrade Package</b> : Display the items to be upgraded. <b>Upgrade Status</b> : Display a list of the additional functions provided by the upgrade. <b>Upgrade Start</b> : Execute the upgrade process. When the upgrade starts, the power indicator becomes red and the menu screen is shut down. During the upgrade, the amount of upgrade time which has elapsed is displayed. When upgrading is complete, the power indicator becomes green and normal status is resumed.</p> <ul style="list-style-type: none"> <li>• If the upgrade is not successful, an error message identical to those in "Update" will appear on the display. Check the settings and network environment and then perform the upgrade again.</li> </ul> <p> See the Denon website for details about upgrades. When the procedure is complete, "Registered" is displayed in this menu and upgrades can be carried out. If the procedure has not been carried out, "Not Registered" is displayed. The ID number shown on this screen is needed when carrying out the procedure. The ID number can also be displayed by pressing and holding the main unit's <b>STATUS</b> and <b>SOURCE SELECT</b> ◀ for at least 3 seconds.</p>

#### Notes concerning use of "Update" and "Add New Feature"

- In order to use these functions, you must have the correct system requirements and settings for a broadband Internet connection ([page 19](#)).
- Do not turn off the power until updating or upgrading is completed.
- Even with a broadband connection to the Internet, approximately 1 hour is required for the updating/upgrading procedure to be completed.
- Once updating/upgrade starts, normal operations on this unit cannot be performed until updating/upgrading is completed. Furthermore, there may be cases where backup data is reset for the parameters, etc., set on this unit.
- If the update or upgrade fails, press and hold the  on the main unit for more than 5 seconds, or remove and re-insert the power cord. "Update retry" appears on the display and update restarts from the point at which update failed. If the error continues despite this, check the network environment.



- Information regarding the "Update" function and "Add New Feature" will be announced on the Denon web site each time related plans are defined.
- When usable new firmware is released with "Update" or "Add New Feature", a notification message is displayed on the menu screen. When you do not want to be notified, set "Notifications" – "Update" ([page 127](#)) and "Notifications" – "Upgrade" ([page 127](#)) to "Off".

## Setup Lock

Default settings are underlined.





Protect settings from inadvertent changes.

Setting items	Setting details
<b>Lock</b>	<p><b>On</b> : Turn protection on. <b>Off</b> : Turn protection off.</p> <p> When cancelling the setting, set "Lock" to "Off".</p> <p><b>NOTE</b> When "Lock" is set to "On", the settings listed below can no longer be changed. Also, "Setup Locked!" is displayed if you attempt to operate related settings.</p> <ul style="list-style-type: none"> <li>• Setup menu operations</li> </ul>

## Information

---

Here we list other information related to this unit.  
Please refer to this information as needed.

- Part names and functions  [page 130](#)
- Other information  [page 135](#)
- Troubleshooting  [page 145](#)
- Specifications  [page 149](#)
- Index  [page 150](#)



# Part names and functions

## Front panel

For buttons not explained here, see the page indicated in parentheses ( ).

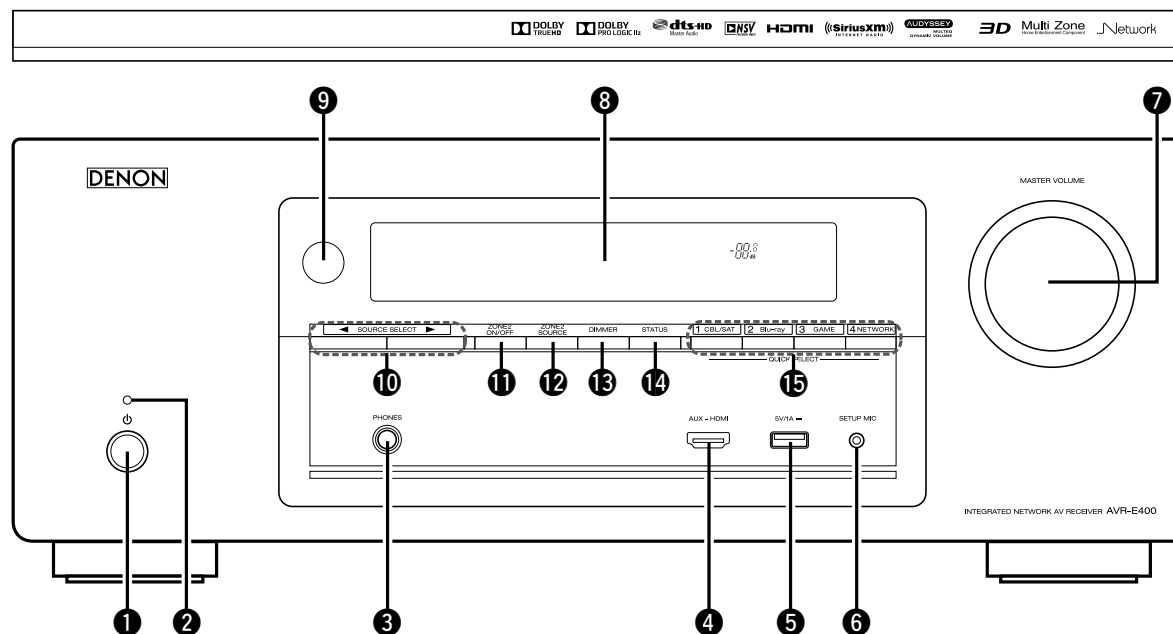

- |  |   |  |
|--|---|--|
| <p><b>1 Power operation button (b)</b> ..... (28)<br/>Turns power to this unit on and off (standby).</p> <p><b>2 Power indicator</b> ..... (28)<br/><b>[Power indicator status]</b></p> <ul style="list-style-type: none"> <li>• Power on : Green</li> <li>• Normal standby : Off</li> <li>• When "HDMI Pass Through" or "HDMI Control" (page 108) is set to "On" : Red</li> <li>• When "IP Control" (page 120) is set to "Always On" : Red</li> </ul> | <p><b>3 Headphones jack (PHONES)</b> ..... (10)<br/>When the headphones are plugged into this jack, audio will no longer be output from the connected speakers.</p> <p><b>NOTE</b></p> <p>To prevent hearing loss, do not raise the volume level excessively when using headphones.</p> <p><b>4 AUX-HDMI connector</b> ..... (10)</p> <p><b>5 USB port</b> ..... (16, 34)</p> <p><b>6 SETUP MIC jack</b> ..... (22, 86)</p> | <p><b>7 MASTER VOLUME knob</b> ..... (29, 93)</p> <p><b>8 Display</b> ..... (131)</p> <p><b>9 Remote control sensor</b> ..... (134)</p> <p><b>10 SOURCE SELECT buttons</b> ..... (28)</p> <p><b>11 ZONE2 ON/OFF button</b> ..... (93)</p> <p><b>12 ZONE2 SOURCE button</b> ..... (93)</p> <p><b>13 DIMMER button</b> ..... (125)</p> <p><b>14 STATUS button</b> ..... (31, 46, 50, 62, 126)</p> <p><b>15 QUICK SELECT buttons</b> ..... (90)</p> |
|--|---|--|

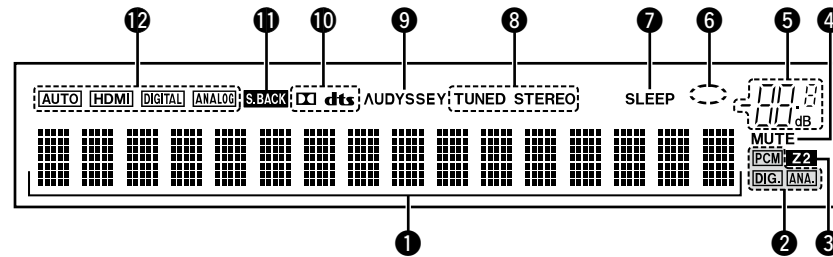

## 1 Information display

The input source name, sound mode, setting values and other information are displayed here.

## 2 Input signal indicators

## 3 MULTI ZONE indicators

This lights up when ZONE2 (separate room) power is turned on ([page 93](#)).

## 4 MUTE indicator

This lights when the audio mute mode is selected ([page 29](#)).

## 5 Master volume indicator

## 6 Circle indicator

Circle indicator is displayed when the input source is "NETWORK" or "iPod/USB" when you are playing back music.

## 7 Sleep timer indicator

This lights when the sleep mode is selected ([page 89](#)).

## 8 Tuner reception mode indicators

These light according to the reception conditions when the input source is set to "TUNER".

**STEREO** : In FM mode, this lights up when receiving stereo broadcasts.

**TUNED** : Lights up when the broadcast is properly tuned in.

## 9 Audyssey® indicator

This indicator lights when the "MultEQ®" ([page 104](#)), "Dynamic EQ" ([page 105](#)) or "Dynamic Volume" ([page 105](#)) setting is set to other than "Off".

## 10 Decoder indicator

These light when Dolby or DTS signals are input or when the Dolby or DTS decoder is running.

## 11 Surround back indicator

This lights when audio signals are being output from the surround back speakers ([page 116](#)).

## 12 Input mode indicators

Set the audio input modes for the different input sources ([page 114](#)).

# Rear panel

See the page indicated in parentheses ( ).

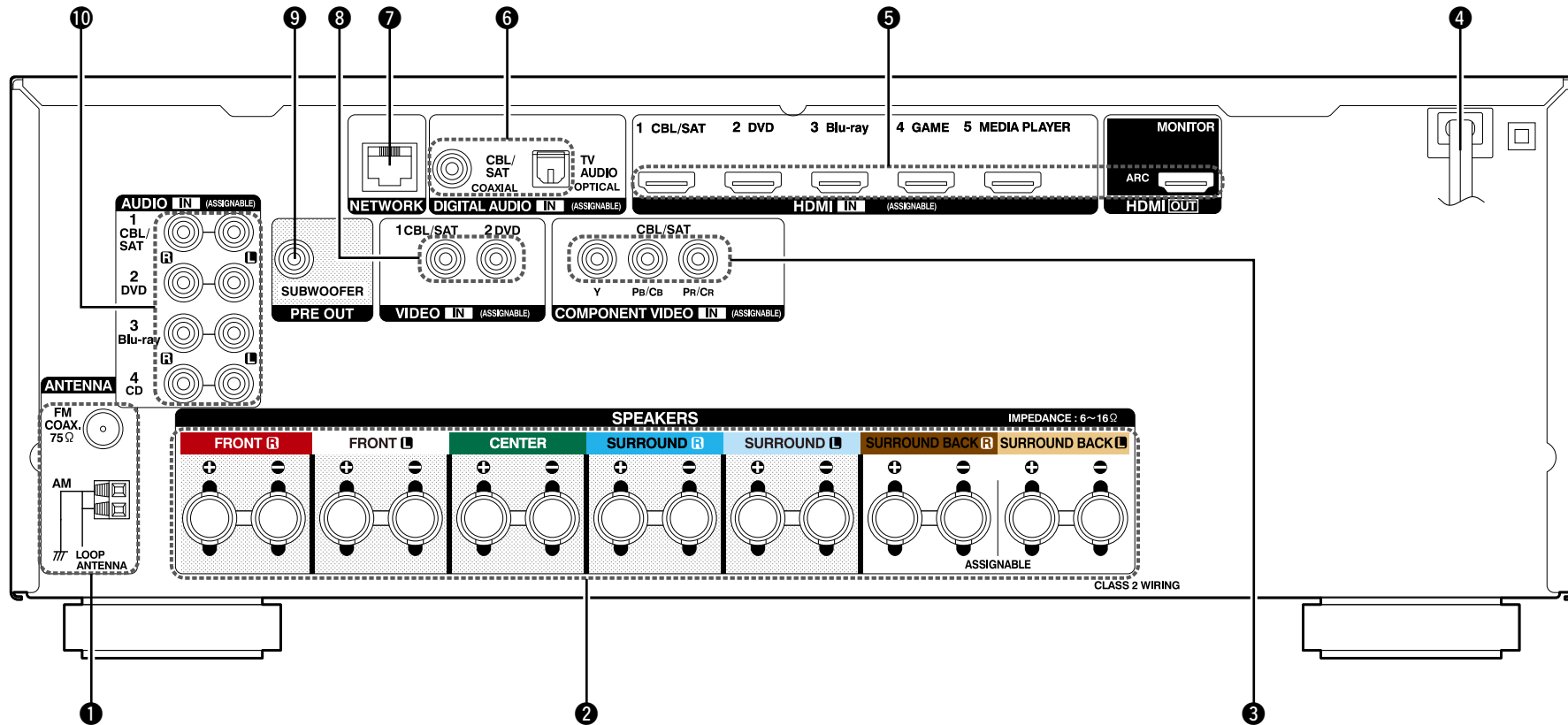

- ❶ FM/AM antenna terminals (ANTENNA) ..... (18)
- ❷ Speaker terminals (SPEAKERS) ..... (81, 82, 83, 84, 85, 93)
- ❸ Component video connectors (COMPONENT VIDEO) ..... (14)
- ❹ Power cord ..... (20)
- ❺ HDMI connectors ..... (9, 10)
- ❻ Digital audio connectors (DIGITAL AUDIO) ..... (13, 14)
- ❼ Network connector (NETWORK) ..... (19)
- ❽ Video connectors (VIDEO) ..... (13, 14, 15)
- ❾ PRE OUT connector ..... (81, 82, 83, 84, 85)
- ❿ Analog audio connectors (AUDIO) ..... (14, 15, 17)

**NOTE**

Do not touch the inner pins of the connectors on the rear panel. Electrostatic discharge may cause permanent damage to the unit.

# Remote control unit

For buttons not explained here, see the page indicated in parentheses ( ).

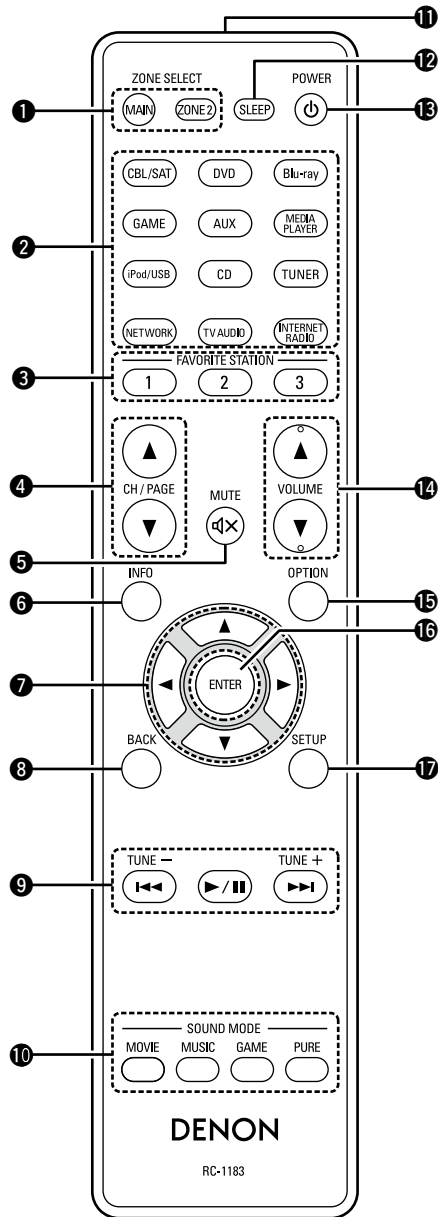

- 1 ZONE SELECT buttons**  
(MAIN, ZONE2) ..... (22, 68, 86, 93, 134)
- 2 Input source select buttons** ..... (28, 93)
- 3 FAVORITE STATION buttons**  
(1 – 3) ..... (65)
- 4 Channel/page search buttons**  
(CH/PAGE ▲▼) ..... (32, 35, 39, 44, 47, 51, 54, 58, 60, 62)
- 5 MUTE button** (⊘) ..... (29, 93)
- 6 Information button (INFO)** ..... (126)
- 7 Cursor buttons** (▲▼◀▶) ..... (98, 100, 106, 111, 115, 119, 123)
- 8 BACK button** ..... (34, 46, 50, 53, 59, 62)
- 9 System buttons** ..... (32, 35, 51, 58)
  - Skip buttons (⏮, ⏭)
  - Play/pause button (▶/⏸)
- Tuning up / Tuning down buttons**  
(TUNE +, -) ..... (36, 40)
- 10 SOUND MODE buttons** ..... (71)
  - MOVIE button
  - MUSIC button
  - GAME button
  - PURE button
- 11 Remote control signal transmitter** ..... (134)
- 12 SLEEP button** ..... (89, 94)
- 13 POWER button** (⏻) ..... (28, 93)
- 14 VOLUME buttons** (▲▼) ..... (29, 93)
- 15 OPTION button** ..... (30, 34, 37, 46, 51, 53, 62)
- 16 ENTER button** ..... (98, 100, 106, 111, 115, 119, 123)
- 17 SETUP button** ..... (98, 100, 106, 111, 115, 119, 123)

## Inserting the batteries

- ① Remove the rear lid in the direction of the arrow and remove it.
- ② Load the two batteries properly as indicated by the marks in the battery compartment.

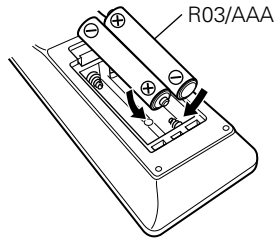
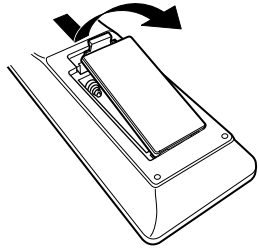

- ③ Put the rear cover back on.

### NOTE

- Insert the specified batteries in the remote control unit.
- Replace the batteries with new ones if the set does not operate even when the remote control unit is operated close to the unit. (The supplied batteries are only for verifying operation. Replace them with new batteries at an early date.)
- When inserting the batteries, be sure to do so in the proper direction, following the ⊕ and ⊖ marks in the battery compartment.
- To prevent damage or leakage of battery fluid:
  - Do not use a new battery together with an old one.
  - Do not use two different types of batteries.
  - Do not attempt to charge dry batteries.
  - Do not short-circuit, disassemble, heat or dispose of batteries in flames.
  - Do not keep the battery in a place exposed to direct sunlight or in places with extremely high temperatures, such as near a heater.
- If the battery fluid should leak, carefully wipe the fluid off the inside of the battery compartment and insert new batteries.
- Remove the batteries from the remote control unit if it will not be in use for long periods.
- Used batteries should be disposed of in accordance with the local regulations regarding battery disposal.
- The remote control unit may function improperly if rechargeable batteries are used.

## Operating range of the remote control unit

Point the remote control unit at the remote sensor when operating it.

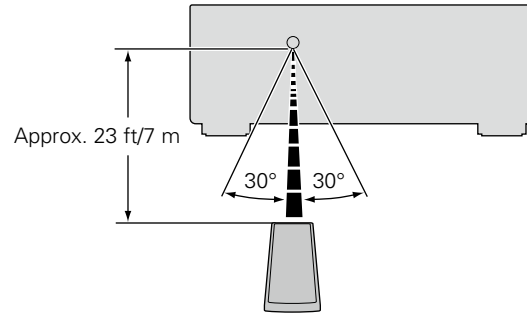

### NOTE

- The set may function improperly or the remote control unit may not operate if the remote control sensor is exposed to direct sunlight, strong artificial light from an inverter type fluorescent lamp or infrared light.
- When using 3D video devices that transmit infrared communication signals (such as infrared signals etc) between the various units (such as the monitor, 3D glasses, 3D transmitter unit etc), the remote control unit may not operate due to interference from those communication signals. If this occurs, adjust the direction and distance of the 3D communication for each unit, and check that the remote control unit operation is not affected by these signals.

## Specifying the zone used with the remote control unit

When the **ZONE2** button is pressed, only the MAIN ZONE can be operated with the remote control unit.

**Press and hold ZONE2 and SETUP.**  
**MAIN** and **ZONE2** button blink.

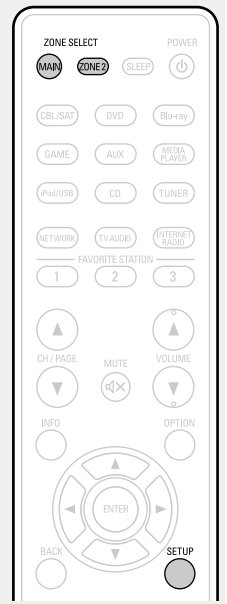

**To cancel**

**Press and hold ZONE2 and SETUP.**  
**MAIN** and **ZONE2** button blink.

# Other information

- ❑ **Trademark information** (👉 [page 135](#))
- ❑ **Surround** (👉 [page 136](#))
- ❑ **Relationship between video signals and monitor output** (👉 [page 140](#))
- ❑ **Explanation of terms** (👉 [page 142](#))

## Trademark information

This product uses the following technologies (Random order):



Manufactured under license from Audyssey Laboratories™. U.S. and foreign patents pending. Audyssey MultEQ®, Audyssey Dynamic EQ® and Audyssey Dynamic Volume® are registered trademarks of Audyssey Laboratories.



Manufactured under license from Dolby Laboratories. “Dolby”, “Pro Logic” and the double-D symbol are trademarks of Dolby Laboratories.



Manufactured under license under U.S. Patent Nos: 5,956,674; 5,974,380; 6,226,616; 6,487,535; 7,212,872; 7,333,929; 7,392,195; 7,272,567 & other U.S. and worldwide patents issued & pending. DTS-HD, the Symbol, & DTS-HD and the Symbol together are registered trademarks & DTS-HD Master Audio is a trademark of DTS, Inc. Product includes software. © DTS, Inc. All Rights Reserved.



The terms HDMI and HDMI High-Definition Multimedia Interface, and the HDMI Logo are trademarks or registered trademarks of HDMI Licensing LLC in the United States and other countries.



“Made for iPod” and “Made for iPhone” mean that an electronic accessory has been designed to connect specifically to iPod, or iPhone, respectively, and has been certified by the developer to meet Apple performance standards.

Apple is not responsible for the operation of this device or its compliance with safety and regulatory standards. Please note that the use of this accessory with iPod, or iPhone, may affect wireless performance.

AirPlay, the AirPlay logo, iPad, iPhone, iPod, iPod classic, iPod nano, iPod shuffle and iPod touch are trademarks of Apple Inc., registered in the U.S. and other countries.

- Individual users are permitted to use iPhone, iPod, iPod classic, iPod nano, iPod shuffle, and iPod touch for private copy and playback of non-copyrighted contents and contents whose copy and playback is permitted by law. Copyright infringement is prohibited by law.



Windows Media and the Windows logo are trademarks or registered trademarks of Microsoft Corporation in the United States and/or other countries.

# Surround

This unit is equipped with a sophisticated digital signal processing circuit that lets you play your favorite movie and music sources and listen to them with a wide range of surround sound mode choices.

## Sound modes and surround parameters

This table shows the speakers that can be used in each sound mode and the surround parameters adjustable in each sound mode.

### Symbols in the table

- This indicates the audio output channels or surround parameters that can be set.
- ⊙ This indicates the audio output channels. The output channels depend on the settings of "Speaker Config." ([page 116](#)).

Sound Mode ( <a href="#">page 71</a> )	Channel output						Surround Parameter ( <a href="#">page 101</a> )				
	Front L/R	Center	Surround L/R	Surround back L/R	Front height L/R	Subwoofer	Cinema EQ ( <a href="#">page 101</a> )	Loudness Management *2 ( <a href="#">page 101</a> )	Dynamic Compression *3 ( <a href="#">page 101</a> )	Low Frequency Effects *4 ( <a href="#">page 102</a> )	Delay Time ( <a href="#">page 102</a> )
DIRECT/PURE DIRECT (2-channel)*1	○					⊙*5		○	○		
DIRECT/PURE DIRECT (Multi-channel)*1	○	⊙	⊙	⊙*6	⊙*6	⊙		○	○	○	
STEREO	○					⊙		○	○	○	
MULTI CH IN	○	⊙	⊙	⊙	⊙*7	⊙	○*8			○	
DOLBY PRO LOGIC IIz	○	⊙	⊙		⊙*7	⊙	○	○	○		
DOLBY PRO LOGIC IIx	○	⊙	⊙	⊙		⊙	○*9	○	○		
DOLBY PRO LOGIC II	○	⊙	⊙			⊙	○*10	○	○		
DTS NEO:6	○	⊙	⊙	⊙		⊙	○*9	○	○		
DOLBY DIGITAL	○	⊙	⊙	⊙	⊙*7	⊙	○*8		○	○	
DOLBY DIGITAL Plus	○	⊙	⊙	⊙	⊙*7	⊙	○*8			○	
DOLBY TrueHD	○	⊙	⊙	⊙	⊙*7	⊙	○*8	○	○	○	
DTS SURROUND	○	⊙	⊙	⊙	⊙*7	⊙	○*8		○	○	
DTS 96/24	○	⊙	⊙	⊙	⊙*7	⊙	○*8		○	○	
DTS-HD	○	⊙	⊙	⊙	⊙*7	⊙	○*8		○	○	
DTS Express	○	⊙	⊙	⊙	⊙*7	⊙	○*8		○	○	
MULTI CH STEREO	○	⊙	⊙	⊙	⊙	⊙		○	○	○	
ROCK ARENA	○	⊙	⊙	⊙	⊙	⊙		○	○	○	
JAZZ CLUB	○	⊙	⊙	⊙	⊙	⊙		○	○	○	
MONO MOVIE	○	⊙	⊙	⊙	⊙	⊙		○	○	○	
VIDEO GAME	○	⊙	⊙	⊙	⊙	⊙		○	○	○	
MATRIX	○	⊙	⊙	⊙	⊙	⊙		○	○	○	○
VIRTUAL	○					⊙		○	○	○	

- \*1 During playback in PURE DIRECT mode, the surround parameters are the same as in DIRECT mode.
- \*2 This item can be selected when a Dolby TrueHD signal is played.
- \*3 This item can be selected when a Dolby Digital or DTS signal is played.
- \*4 This item can be selected when a Dolby Digital or DTS signal or DVD-Audio is played.
- \*5 Only when "Subwoofer Mode" is set to "LFE+Main" ([page 118](#)), sound is output from the subwoofer.
- \*6 A signal for each channel contained in an input signal is output as audio.
- \*7 Audio is output from the front height speaker when the set sound mode name contains "+PLIIz". For information on how to check the sound mode, see [page 71](#).
- \*8 This setting is unavailable when the set sound mode name contains "+PLIIx Music". For information on how to check the sound mode, see [page 71](#).
- \*9 This setting is possible when the sound mode is "PLIIx Cinema" or "DTS NEO:6 Cinema".
- \*10 This setting is possible when the sound mode is "PLII Cinema".

Sound Mode (page 71)	Surround Parameter (page 101)							Subwoofer (page 101)	Tone *12 (page 103)	Audyssey (page 104)			Restorer *15 (page 103)
	Effect Level (page 102)	Room Size (page 102)	Height Gain *11 (page 102)	PRO LOGIC II/IIx Music mode only			NEO:6 Music mode only			MultEQ® *13 (page 104)	Dynamic EQ *14 (page 105)	Dynamic Volume *14 (page 105)	
				Panorama (page 102)	Dimension (page 102)	Center Width (page 102)	Center Image (page 102)						
DIRECT/PURE DIRECT (2-channel)*1								<input type="radio"/> *5					
DIRECT/PURE DIRECT (Multi-channel)*1								<input type="radio"/>					
STEREO								<input type="radio"/>	<input type="radio"/>	<input type="radio"/>	<input type="radio"/>	<input type="radio"/>	<input type="radio"/>
MULTI CH IN			<input type="radio"/>					<input type="radio"/>	<input type="radio"/>	<input type="radio"/>	<input type="radio"/>	<input type="radio"/>	<input type="radio"/>
DOLBY PRO LOGIC IIz			<input type="radio"/>					<input type="radio"/>	<input type="radio"/>	<input type="radio"/>	<input type="radio"/>	<input type="radio"/>	<input type="radio"/>
DOLBY PRO LOGIC IIx				<input type="radio"/>	<input type="radio"/>	<input type="radio"/>		<input type="radio"/>	<input type="radio"/>	<input type="radio"/>	<input type="radio"/>	<input type="radio"/>	<input type="radio"/>
DOLBY PRO LOGIC II				<input type="radio"/>	<input type="radio"/>	<input type="radio"/>		<input type="radio"/>	<input type="radio"/>	<input type="radio"/>	<input type="radio"/>	<input type="radio"/>	<input type="radio"/>
DTS NEO:6							<input type="radio"/>	<input type="radio"/>	<input type="radio"/>	<input type="radio"/>	<input type="radio"/>	<input type="radio"/>	<input type="radio"/>
DOLBY DIGITAL			<input type="radio"/>					<input type="radio"/>	<input type="radio"/>	<input type="radio"/>	<input type="radio"/>	<input type="radio"/>	<input type="radio"/>
DOLBY DIGITAL Plus			<input type="radio"/>					<input type="radio"/>	<input type="radio"/>	<input type="radio"/>	<input type="radio"/>	<input type="radio"/>	<input type="radio"/>
DOLBY TrueHD			<input type="radio"/>					<input type="radio"/>	<input type="radio"/>	<input type="radio"/>	<input type="radio"/>	<input type="radio"/>	<input type="radio"/>
DTS SURROUND			<input type="radio"/>					<input type="radio"/>	<input type="radio"/>	<input type="radio"/>	<input type="radio"/>	<input type="radio"/>	<input type="radio"/>
DTS 96/24			<input type="radio"/>					<input type="radio"/>	<input type="radio"/>	<input type="radio"/>	<input type="radio"/>	<input type="radio"/>	<input type="radio"/>
DTS-HD			<input type="radio"/>					<input type="radio"/>	<input type="radio"/>	<input type="radio"/>	<input type="radio"/>	<input type="radio"/>	<input type="radio"/>
DTS Express			<input type="radio"/>					<input type="radio"/>	<input type="radio"/>	<input type="radio"/>	<input type="radio"/>	<input type="radio"/>	<input type="radio"/>
MULTI CH STEREO								<input type="radio"/>	<input type="radio"/>	<input type="radio"/>	<input type="radio"/>	<input type="radio"/>	<input type="radio"/>
ROCK ARENA	<input type="radio"/>	<input type="radio"/>						<input type="radio"/>	<input type="radio"/> *16	<input type="radio"/>	<input type="radio"/>	<input type="radio"/>	<input type="radio"/>
JAZZ CLUB	<input type="radio"/>	<input type="radio"/>						<input type="radio"/>	<input type="radio"/>	<input type="radio"/>	<input type="radio"/>	<input type="radio"/>	<input type="radio"/>
MONO MOVIE	<input type="radio"/>	<input type="radio"/>						<input type="radio"/>	<input type="radio"/>	<input type="radio"/>	<input type="radio"/>	<input type="radio"/>	<input type="radio"/>
VIDEO GAME	<input type="radio"/>	<input type="radio"/>						<input type="radio"/>	<input type="radio"/>	<input type="radio"/>	<input type="radio"/>	<input type="radio"/>	<input type="radio"/>
MATRIX								<input type="radio"/>	<input type="radio"/>	<input type="radio"/>	<input type="radio"/>	<input type="radio"/>	<input type="radio"/>
VIRTUAL								<input type="radio"/>	<input type="radio"/>	<input type="radio"/>	<input type="radio"/>	<input type="radio"/>	<input type="radio"/>

- \*1 During playback in PURE DIRECT mode, the surround parameters are the same as in DIRECT mode.
- \*5 Only when "Subwoofer Mode" is set to "LFE+Main" (page 118), sound is output from the subwoofer.
- \*11 This setting is available when the set sound mode name contains "+PLIIz". For information on how to check the sound mode, see page 71.
- \*12 This item cannot be set when "Dynamic EQ" (page 105) is set to "On".
- \*13 For HD Audio whose sampling frequency of an input signal is more than 96 kHz, this sound parameter cannot be set.
- \*14 This item cannot be set when "MultEQ®" (page 104) is set to "Off" or "Graphic EQ".
- \*15 This item can be set when the input signal is analog, PCM 48 kHz or 44.1 kHz.
- \*16 In this sound mode, bass is +6 dB, and treble is +4 dB (Default).



### Types of input signals, and corresponding sound modes

This table shows the input signal that can be played in each sound mode. Check the audio signal of the input source then select the sound mode.

#### Symbols in the table

- This indicates the default sound mode.
- This indicates the selectable sound mode.

Sound Mode (🔗 page 71)	NOTE	Input signal types and formats														
		ANALOG	PCM		DTS-HD		DTS					DOLBY		DOLBY DIGITAL		
			PCM (Multi-channel)	PCM (2-channel)	DTS-HD Master Audio	DTS-HD High Resolution Audio	DTS EXPRESS	DTS ES DSCRT (With Flag)	DTS ES MTRX (With Flag)	DTS (5.1-channel)	DTS 96/24	DOLBY TrueHD	DOLBY DIGITAL Plus	DOLBY DIGITAL EX (With Flag)	DOLBY DIGITAL EX (With no Flag)	DOLBY DIGITAL (5.1-channel)
<b>DTS SURROUND</b>																
DTS-HD MSTR					●											
DTS-HD HI RES						●										
DTS ES DSCRT6.1	*1*2							●								
DTS ES MTRX6.1	*1*2							●								
DTS SURROUND																
DTS 96/24																
DTS (-HD) + PLIIx CINEMA	*1*3				○	○	○				○	○				
DTS (-HD) + PLIIx MUSIC	*1*2				○	○	○				○	○				
DTS (-HD) + PLIIz	*4*5				○	○	○	○	○	○	○	○				
DTS EXPRESS								●								
DTS (-HD) + NEO:6	*1*2				○	○					○	○				
DTS NEO:6 CINEMA		○														○
DTS NEO:6 MUSIC		○		○												○
<b>DOLBY SURROUND</b>																
DOLBY TrueHD													●			
DOLBY DIGITAL+														●		
DOLBY DIGITAL EX	*1*2													○	○	○
DOLBY (D+) (HD) +EX	*1*2												○	○		
DOLBY DIGITAL															●	●
DOLBY (D) (D+) (HD) +PLIIx CINEMA	*1*3												○	○	○	○
DOLBY (D) (D+) (HD) +PLIIx MUSIC	*1*2												○	○	○	○
DOLBY (D) (D+) (HD) +PLIIz	*4												○	○	○	○
DOLBY PRO LOGIC IIx CINEMA	*1*2	○		○												○
DOLBY PRO LOGIC IIx MUSIC	*1*2	○		○												○
DOLBY PRO LOGIC IIx GAME	*1*2	○		○												○
DOLBY PRO LOGIC IIz	*4*5	○		○												○
DOLBY PRO LOGIC II CINEMA		○		○												○
DOLBY PRO LOGIC II MUSIC		○		○												○
DOLBY PRO LOGIC II GAME		○		○												○

- \*1 This sound mode can be selected when "Amp Assign" (🔗 page 116) is set to "Surround Back".
- \*2 If "Speaker Config." - "Surr. Back" (🔗 page 116) is set to "None", this sound mode cannot be selected.
- \*3 If "Speaker Config." - "Surr. Back" (🔗 page 116) is set to "1spkr" or "None", this sound mode cannot be selected.
- \*4 If "Speaker Config." - "Front Height" (🔗 page 116) is set to "None", this sound mode cannot be selected.

Sound Mode (☞ page 71)	NOTE	Input signal types and formats																
		ANALOG	PCM		DTS-HD		DTS					DOLBY		DOLBY DIGITAL				
			PCM (Multi-channel)	PCM (2-channel)	DTS-HD Master Audio	DTS-HD High Resolution Audio	DTS EXPRESS	DTS ES DSCRT (With Flag)	DTS ES MTRX (With Flag)	DTS (5.1-channel)	DTS 96/24	DOLBY TrueHD	DOLBY DIGITAL Plus	DOLBY DIGITAL EX (With Flag)	DOLBY DIGITAL EX (With no Flag)	DOLBY DIGITAL (5.1-channel)	DOLBY DIGITAL (2-channel)	
MULTI CH IN																		
MULTI CH IN			●															
MULTI CH IN + PLIIx CINEMA	*1*3		○															
MULTI CH IN + PLIIx MUSIC	*1*2		○															
MULTI CH IN + PLIIz	*1*4		○															
MULTI CH IN + Dolby EX	*1*2		○															
MULTI CH IN 7.1	*1*2		● (7.1)															
DIRECT																		
DIRECT		○	○	○	○	○	○	○	○	○	○	○	○	○	○	○	○	○
PURE DIRECT																		
PURE DIRECT		○	○	○	○	○	○	○	○	○	○	○	○	○	○	○	○	○
DSP SIMULATION																		
MULTI CH STEREO		○	○	○	○	○	○	○	○	○	○	○	○	○	○	○	○	○
ROCK ARENA		○	○	○	○	○	○	○	○	○	○	○	○	○	○	○	○	○
JAZZ CLUB		○	○	○	○	○	○	○	○	○	○	○	○	○	○	○	○	○
MONO MOVIE		○	○	○	○	○	○	○	○	○	○	○	○	○	○	○	○	○
VIDEO GAME		○	○	○	○	○	○	○	○	○	○	○	○	○	○	○	○	○
MATRIX		○	○	○	○	○	○	○	○	○	○	○	○	○	○	○	○	○
VIRTUAL		○	○	○	○	○	○	○	○	○	○	○	○	○	○	○	○	○
STEREO																		
STEREO		●	○	●	○	○	○	○	○	○	○	○	○	○	○	○	○	○

- \*1 This sound mode can be selected when "Amp Assign" (☞ page 116) is set to "Surround Back".
- \*2 If "Speaker Config." - "Surr. Back" (☞ page 116) is set to "None", this sound mode cannot be selected.
- \*3 If "Speaker Config." - "Surr. Back" (☞ page 116) is set to "1spkr" or "None", this sound mode cannot be selected.
- \*4 If "Speaker Config." - "Front Height" (☞ page 116) is set to "None", this sound mode cannot be selected.

## Relationship between video signals and monitor output

MAIN ZONE MONITOR OUT					
Video Conversion	Input connector			Output connector	Menu displayed
	HDMI	COMPONENT	VIDEO	HDMI	HDMI
On	×	×	×	×	Only the menu is displayed
On	×	×	○	○ <VIDEO>	○ (VIDEO)
On	×	○	×	○ <COMPONENT>	○ (COMPONENT)
On	×	○	○		
On	○	×	×	○ <HDMI>	○ (HDMI)
On	○	×	○		
On	○	○	×		
On	○	○	○		
Off	×	×	×	×	Only the menu is displayed
Off	×	×	○		
Off	×	○	×		
Off	×	○	○		
Off	○	×	×	○ <HDMI>	
Off	○	×	○		
Off	○	○	×		
Off	○	○	○		

○ : Video signal input present  
 × : No video signal input

○ <> : The input signal between the < > marks is output. ○ ( ) : Superimposed on the picture indicated in ( ).  
 × : No video signal output



The main zone video conversion function is compatible with the following formats: NTSC, PAL, SECAM, NTSC4.43, PAL-N, PAL-M and PAL-60.

### NOTE

- The status display screen cannot be displayed at a computer's resolution (e.g. VGA) or while certain 3D video contents is being played.
- When the menu is operated on a computer's resolution (e.g. VGA) or during playback of certain 3D video content, the playback image switches to the menu screen image.

## Video signal resolution conversion table

When “Video Conversion” ([page 108](#)) is set to “On”, “i/p Scaler” ([page 109](#)) is set to “Analog”, “Analog & HDMI” or “HDMI” are set, the resolution of the input video signal can be converted to a different resolution for output ([page 6](#) “Converting input video signals for HD output (Video conversion function”).

The relationship between the resolution of the convertible video signal and HDMI output resolution is shown in the table below.

	Input resolution	Output resolution	HDMI Output						
			480i/576i *1	480p/576p	1080i	720p	1080p	1080p 24Hz	4K *2
Video input	480i/576i		○	○	○	○	○	○	○
Component video input	480i/576i		○	○	○	○	○	○	○
	480p/576p		–	○	○	○	○	○	○
	1080i		–	–	○	○	○	○	○
	720p		–	–	○	○	○	○	○
	1080p		–	–	–	–	○	○	○
HDMI input	480i/576i		○	○	○	○	○	○	○
	480p/576p		–	○	○	○	○	○	○
	1080i		–	–	○	○	○	○	○
	720p		–	–	○	○	○	○	○
	1080p 24Hz		–	–	–	–	○*3	○*4	○
	1080p		–	–	–	–	○	○	○
	4K		–	–	–	–	–	–	○*5

○ The resolution set in “Resolution” ([page 109](#)) in the menu is output.

– Output at the same resolution as the input video signal resolution.

\*1 Only output when “i/p Scaler” in the menu is set to “Off”.

\*2 Output at a resolution of 3840 x 2160 pixels (24/25/30 Hz).

\*3 The resolution set in “Resolution” ([page 109](#)) in the menu is set to “Auto”, and a television that does not support 1080p 24Hz video signals is connected.

\*4 The resolution set in “Resolution” ([page 109](#)) in the menu is set to “Auto”, and a television that supports 1080p 24Hz video signals is connected.

\*5 Output at the same resolution as the input video signal resolution.

### NOTE

- The 4K, 3D, Computer resolution, “x.v.Color”, sYCC601 color, Adobe RGB color or Adobe YCC601 color input to HDMI is output at the same resolution as the input video signal.
- When “Video Mode” in the menu is set to “Game” or “Auto” and game contents are played, the same resolution as the input video signal is output.
- When “Resolution” in the menu is set to “Auto”, the number of pixels in the television panel connected to the HDMI output connector is automatically detected, and the optimum resolution is output according to the table above.
- If 1080p 24Hz signals input from the HDMI terminal are converted into 1080p 60Hz/1080p 50Hz for output, they are output according to the specified “Format” ([page 110](#)) setting in the menu:
  - “NTSC” – Output as 1080p 60Hz.
  - “PAL” – Output as 1080p 50Hz.
- You can not convert 60Hz into 50Hz or vice versa.
- You can not convert 50Hz into 24Hz.

## Explanation of terms

### A

#### **Adobe RGB color, Adobe YCC601 color**

The color space defined by Adobe Systems Inc. Because it is a wider color space than RGB, it can produce more vivid and natural images.

#### **AirPlay**

AirPlay sends (plays) contents recorded in iTunes or on an iPhone/iPod touch/iPad to a compatible device via the network.

#### **ALAC (Apple Lossless Audio Codec)**

This is a codec for lossless audio compression method developed by Apple Inc. This codec can be played back on iTunes, iPod or iPhone. Data compressed to approximately 60 – 70 % can be decompressed to exactly the same original data.

#### **App Store**

App Store is a site that sells application software for such devices as the iPhone or iPod Touch, and is operated by Apple Inc.

#### **Audyssey Dynamic EQ®**

Dynamic EQ solves the problem of deteriorating sound quality as volume is decreased by taking into account human perception and room acoustics. Audyssey Dynamic EQ® works in tandem with Audyssey MultEQ® to provide well-balanced sound for every listener at any volume level.

#### **Audyssey Dynamic Volume®**

Dynamic Volume solves the problem of large variations in volume level between television programs, commercials, and between the soft and loud passages of movies. Audyssey Dynamic EQ® is integrated into Dynamic Volume so that as the playback volume is adjusted automatically, the perceived bass response, tonal balance, surround impression, and dialog clarity remain the same.

#### **Audyssey MultEQ®**

MultEQ® is a room equalization solution that calibrates any audio system so that it can achieve optimum performance for every listener in a large listening area. Based on several room measurements, MultEQ® calculates an equalization solution that corrects for both time and frequency response problems in the listening area and also performs a fully automated surround system setup.

#### **Auto Lip Sync**

If you connect the unit to a TV that supports the Auto Lip Sync function, it can automatically correct delay between the audio and video.

### D

#### **Deep Color**

An imaging technology supported by HDMI. Unlike RGB, which uses 8 bits (256 shades) per color, it can use 10 bits (1024 shades), 12 bits (4096 shades), or 16 bits (65536 shades) to produce colors in higher definition.

Both devices linked via HDMI must support Deep Color.

#### **DLNA**

DLNA and DLNA CERTIFIED are trademarks and/or service marks of Digital Living Network Alliance. Some contents may not be compatible with other DLNA CERTIFIED® products.

#### **Dolby Digital**

Dolby Digital is a multi-channel digital signal format developed by Dolby Laboratories.

A total of 5.1 channels are played: 3 front channels ("FL", "FR" and "C"), 2 surround channels ("SL" and "SR") and the "LFE" channel for low frequencies.

Because of this, there is no crosstalk between channels and a realistic sound field with a "three-dimensional" feeling (sense of distance, movement and positioning) is achieved. This delivers a thrilling surround sound experience in the home.

#### **Dolby Digital EX**

Dolby Digital EX is a 6.1-channel surround format from Dolby Laboratories that allows users to enjoy in their homes the "DOLBY DIGITAL SURROUND EX" audio format jointly developed by Dolby Laboratories and Lucasfilm.

The 6.1 channels of sound, including surround back channel, provide improved sound positioning and expansion of the surround sound field.

#### **Dolby Digital Plus**

Dolby Digital Plus is an improved Dolby Digital signal format that is compatible with up to 7.1 channels of discrete digital sound and also improves sound quality thanks to extra data bit rate performance. It is upwardly compatible with conventional Dolby Digital, so it offers greater flexibility in response to the source signal and the conditions of the playback device.

#### **Dolby Pro Logic II**

Dolby Pro Logic II is a matrix decoding technology developed by Dolby Laboratories.

Regular music such as that on CDs is encoded into 5 channels to achieve an excellent surround effect. The surround channel signals are converted into stereo and full band signals (with a frequency response of 20 Hz to 20 kHz or greater) to create a "three-dimensional" sound image offering a rich sense of presence for all stereo sources.

#### **Dolby Pro Logic IIx**

Dolby Pro Logic IIx is a further improved version of the Dolby Pro Logic II matrix decoding technology. Audio signals recorded in 2 channels are decoded to achieve a natural sound with up to 7.1 channels. There are three modes: "Music" suited for playing music, "Cinema" suited for playing movies, and "Game" which is optimized for playing games.

#### **Dolby Pro Logic IIz**

Dolby Pro Logic IIz introduces a new dimension to Home Entertainment through the addition of a pair of front height channels. Compatible with stereo, 5.1-channel and 7.1-channel content, Dolby Pro Logic IIz provides enhanced spaciousness, depth and dimension to movies, concert video and video game playback while maintaining the full integrity of the source mix.

Dolby Pro Logic IIz identifies and decodes spatial cues that occur naturally in all content, directing this information to the front height channels, complementing the performance of left and right surround sound speakers. Content that is encoded with Dolby Pro Logic IIz height channel information can be even more revealing, with perceptually discrete height channel information bringing an exciting new dimension to home entertainment.

Dolby Pro Logic IIz, with front height channels is also an ideal alternative for households that cannot support the placement of back surround speakers of a typical 7.1-channel system but may have bookshelf space available to support the addition of height speakers.

#### **Dolby TrueHD**

Dolby TrueHD is a high definition audio technology developed by Dolby Laboratories, using lossless coding technology to faithfully reproduce the sound of the studio master.

This format provides the facility to support up to 8 audio channels with a sampling frequency of 96 kHz/24 bit resolution and up to 6 audio channels with a sampling frequency of 192 kHz/24 bit resolution. Dolby TrueHD is adopted for applications that put very high importance on sound quality.

#### **Downmix**

This function converts the number of channels of surround audio to a lower number of channels and plays back according to the system's configuration.

#### **DTS**

This is an abbreviation of Digital Theater System, which is a digital audio system developed by DTS. DTS delivers a powerful and dynamic surround sound experience, and is found in the world's finest movie theaters and screening rooms.

#### **DTS 96/24**

DTS 96/24 is a digital audio format enabling high sound quality playback in 5.1 channels with a sampling frequency of 96 kHz and 24 bit quantization on DVD-Video.

#### **DTS Digital Surround**

DTS Digital Surround is the standard digital surround format of DTS, Inc., compatible with a sampling frequency of 44.1 or 48 kHz and up to 5.1 channels of digital discrete surround sound.

#### **DTS-ES™ Discrete 6.1**

DTS-ES™ Discrete 6.1 is a 6.1-channel discrete digital audio format adding a surround back (SB) channel to the DTS digital surround sound. Decoding of conventional 5.1-channel audio signals is also possible according to the decoder.

#### **DTS-ES™ Matrix 6.1**

DTS-ES™ Matrix 6.1 is a 6.1-channel audio format that inserts a surround back (SB) channel to the DTS digital surround sound through matrix encoding. Decoding of conventional 5.1-channel audio signals is also possible according to the decoder.

**DTS Express**

DTS Express is an audio format supporting low bit rates (max. 5.1 channels, 24 to 256 kbps).

**DTS-HD**

This audio technology provides higher sound quality and enhanced functionality than the conventional DTS and is adopted as an optional audio for Blu-ray Disc. This technology supports multi-channel, high data transfer speed, high sampling frequency, and lossless audio playback. Maximum 7.1-channels are supported in Blu-ray Disc.

**DTS-HD High Resolution Audio**

DTS-HD High Resolution Audio is an improved version of the conventional DTS, DTS-ES and DTS 96/24 signals formats, compatible with sampling frequencies of 96 or 48 kHz and up to 7.1 channels of discrete digital sound. High data bit rate performance provides high quality sound. This format is fully compatible with conventional products, including conventional DTS digital surround 5.1-channel data.

**DTS-HD Master Audio**

DTS-HD Master Audio is a lossless audio format created by Digital Theater System (DTS). This format provides the facility to support up to 8 audio channels with a sampling frequency of 96 kHz/24 bit resolution and up to 6 audio channels with a sampling frequency of 192 kHz/24 bit resolution. It is fully compatible with conventional products, including conventional DTS digital surround 5.1-channel data.

**DTS NEO:6™ Surround**

DTS NEO:6™ is a matrix decoding technology for achieving 6.1-channel surround playback with 2-channel sources. It includes "DTS NEO:6 Cinema" suited for playing movies and "DTS NEO:6 Music" suited for playing music.

**Dynamic range**

The difference between the maximum undistorted sound level and the minimum discernible level above the noise emitted by the device.

**F****FLAC**

FLAC stands for Free lossless Audio Codec, and is a lossless free audio file format. Lossless means that the audio is compressed without any loss in quality. The FLAC license is as shown below.

Copyright (C) 2000, 2001, 2002, 2003, 2004, 2005, 2006, 2007, 2008, 2009 Josh Coalson

Redistribution and use in source and binary forms, with or without modification, are permitted provided that the following conditions are met:

- Redistributions of source code must retain the above copyright notice, this list of conditions and the following disclaimer.
  - Redistributions in binary form must reproduce the above copyright notice, this list of conditions and the following disclaimer in the documentation and/or other materials provided with the distribution.
  - Neither the name of the Xiph.org Foundation nor the names of its contributors may be used to endorse or promote products derived from this software without specific prior written permission.
- THIS SOFTWARE IS PROVIDED BY THE COPYRIGHT HOLDERS AND CONTRIBUTORS "AS IS" AND ANY EXPRESS OR IMPLIED WARRANTIES, INCLUDING, BUT NOT LIMITED TO, THE IMPLIED WARRANTIES OF MERCHANTABILITY AND FITNESS FOR A PARTICULAR PURPOSE ARE DISCLAIMED. IN NO EVENT SHALL THE FOUNDATION OR CONTRIBUTORS BE LIABLE FOR ANY DIRECT, INDIRECT, INCIDENTAL, SPECIAL, EXEMPLARY, OR CONSEQUENTIAL DAMAGES (INCLUDING, BUT NOT LIMITED TO, PROCUREMENT OF SUBSTITUTE GOODS OR SERVICES; LOSS OF USE, DATA, OR PROFITS; OR BUSINESS INTERRUPTION) HOWEVER CAUSED AND ON ANY THEORY OF LIABILITY, WHETHER IN CONTRACT, STRICT LIABILITY, OR TORT (INCLUDING NEGLIGENCE OR OTHERWISE) ARISING IN ANY WAY OUT OF THE USE OF THIS SOFTWARE, EVEN IF ADVISED OF THE POSSIBILITY OF SUCH DAMAGE.

**H****HDCP**

When transmitting digital signals between devices, this copyright protection technology encrypts the signals to prevent content from being copied without authorization.

**HDMI**

This is an abbreviation of High-Definition Multimedia Interface, which is an AV digital interface that can be connected to a TV or amplifier. Video signals and audio signals can be connected using a single cable.

**I****iTunes**

iTunes is the name of the multimedia player provided by Apple Inc. It enables management and playback of multimedia contents including music and movies. iTunes supports many main file formats including AAC, WAV, and MP3.

**L****LFE**

This is an abbreviation of Low Frequency Effect, which is an output channel that emphasizes low frequency effect sound. Surround audio is intensified by outputting 20 Hz to 120 Hz deep bass to the system subwoofer(s).

**M****MAIN ZONE**

The room where this unit is placed is called the MAIN ZONE.

**MP3 (MPEG Audio Layer-3)**

This is an internationally standardized audio data compression scheme, using the "MPEG-1" video compression standard. It compresses the data volume to about one eleventh its original size while maintaining sound quality equivalent to a music CD.

**MPEG (Moving Picture Experts Group),****MPEG-2, MPEG-4**

These are the names for digital compression format standards used for the encoding of video and audio. Video standards include "MPEG-1 Video", "MPEG-2 Video", "MPEG-4 Visual", "MPEG-4 AVC". Audio standards include "MPEG-1 Audio", "MPEG-2 Audio", "MPEG-4 AAC".

**P****Progressive (sequential scanning)**

This is a scanning system of the video signal that displays 1 frame of video as one image. Compared to the interlace system, this system provides images with less flickering and jagged edges.

**Protection Circuit**

This is a function to prevent damage to devices within the power supply when an abnormality such as an overload, excess voltage occurs or over temperature for any reason.

In this unit, the power indicator blinks and the unit enters standby mode when an abnormality occurs.

**S****Sampling frequency**

Sampling involves taking a reading of a sound wave (analog signal) at regular intervals and expressing the height of the wave at each reading in digitized format (producing a digital signal).

The number of readings taken in one second is called the "sampling frequency". The larger the value, the closer the reproduced sound is to the original.

**Speaker impedance**

This is an AC resistance value, indicated in  $\Omega$  (Ohms). Greater power can be obtained when this value is smaller.

**sYCC601 color**

Like "x.v.Color", each of these color spaces defines a palette of available colors that is larger than the traditional RGB color model.

**V****vTuner**

This is a free online content server for Internet Radio. Note that usage fees are included in upgrade costs.

For inquiries about this service, visit the vTuner site below.

vTuner website: <http://www.radiodenon.com>

This product is protected by certain intellectual property rights of Nothing Else Matters Software and BridgeCo. Use or distribution of such technology outside of this product is prohibited without a license from Nothing Else Matters Software and BridgeCo or an authorized subsidiary.

**W****Windows Media DRM**

This is a copyright protection technology developed by Microsoft.

Content providers are using the digital rights management technology for Windows Media contained in this device (WM-DRM) to protect the integrity of their content (Secure Content) so that their intellectual property, including copyright, in such content is not misappropriated. This device uses WM-DRM software to play Secure Content (WM-DRM Software). If the security of the WM-DRM Software in this device has been compromised, owners of Secure Content (Secure Content Owners) may request that Microsoft revoke the WM-DRM Software's right to acquire new licenses to copy, display and/or play Secure Content. Revocation does not alter the WM-DRM Software's ability to play unprotected content. A list of revoked WM-DRM Software is sent to your device whenever you download a license for Secure Content from the Internet or from a PC. Microsoft may, in conjunction with such license, also download revocation list onto your device on behalf of Secure Content Owners.

**Windows Media Player Ver.11 or later**

This is a media player distributed free of charge by Microsoft Corporation.

It can play playlists created with Ver.11 or later of Windows Media Player, as well as WMA, DRM WMA, WAV, and other files.

**WMA (Windows Media Audio)**

This is audio compression technology developed by Microsoft Corporation.

WMA data can be encoded using Windows Media® Player.

To encode WMA files, only use applications authorized by Microsoft Corporation. If you use an unauthorized application, the file may not work properly.

**X****x.v.Color**

This function lets HDTVs display colors more accurately. It enables display with natural, vivid colors. "x.v.Color" is trademark of Sony Corporation.

**Z****ZONE2**

This unit can operate in a room other than the room where this unit is placed (MAIN ZONE) (ZONE2 playback). The room for ZONE2 playback is called ZONE2.

# Troubleshooting

If a problem should arise, first check the following:

**1. Are the connections correct?**

**2. Is the set being operated as described in the owner's manual?**

**3. Are the other devices operating properly?**

If this unit does not operate properly, check the items listed in the table below. Should the problem persist, there may be a malfunction.

In this case, disconnect the power immediately and contact your store of purchase.

## [General]

Symptom	Cause/Solution	Page
Power does not turn on.	<ul style="list-style-type: none"> <li>• Check whether the power plug is correctly inserted into the power outlet.</li> <li>• The protection circuit is active. Disconnect the power plug from the electric outlet, wait 5 to 10 seconds and then insert it back into the outlet.</li> </ul>	<a href="#">20</a> <a href="#">143</a>
Power automatically switches to standby mode.	<ul style="list-style-type: none"> <li>• The sleep timer is set. Turn on the power again, or change the sleep timer settings.</li> <li>• "Auto Standby" is triggered when there is no operation for a set amount of time. To disable "Auto Standby", set "Auto Standby" on the menu to "Off".</li> </ul>	<a href="#">89, 94</a> <a href="#">125</a>
Display is off.	<ul style="list-style-type: none"> <li>• Set "Dimmer" on the menu to something other than "Off".</li> </ul>	<a href="#">125</a>
The power indicator is blinking red in intervals of approximately 2 seconds.	<ul style="list-style-type: none"> <li>• Due to the temperature rise within this unit, the protection circuit is working. Please turn off power once, and re-apply the power after the temperature has fallen sufficiently.</li> <li>• Please re-install this unit in a place having good ventilation.</li> </ul>	<a href="#">143</a> -
The power indicator is blinking red in intervals of approximately 0.5 seconds.	<ul style="list-style-type: none"> <li>• Please use speakers which have the specified impedance.</li> <li>• The protection circuit has been activated because the speaker cable core wires are touching, a core wire has come loose from the terminal, or a core wire is touching the rear panel of this unit. After unplugging the power cord, take corrective action such as firmly re-twisting the core wire or taking care of the terminal, and then reconnect the wire.</li> </ul>	<a href="#">79</a> <a href="#">79</a>

Symptom	Cause/Solution	Page
After turning on the power, the power indicator is blinking red in intervals of approximately 0.5 seconds.	<ul style="list-style-type: none"> <li>• This unit's amplifier circuit has failed. Turn off the power and please contact the Denon service adviser.</li> </ul>	-
Set does not operate properly.	<ul style="list-style-type: none"> <li>• Reset the microprocessor. Note that re-setting the microprocessor restores all pre-configured settings to the factory defaults.</li> </ul>	<a href="#">149</a>

## [HDMI]

Symptom	Cause/Solution	Page
No audio is output with HDMI connection.	<ul style="list-style-type: none"> <li>• Check the connection of the HDMI connectors.</li> <li>• When outputting HDMI audio from the speakers, set "HDMI Audio Out" on the menu to "AVR".</li> <li>• When outputting HDMI audio from a TV, set "HDMI Audio Out" on the menu to "TV".</li> </ul>	<a href="#">9, 10</a> <a href="#">107</a> <a href="#">107</a>
No video is output with HDMI connection.	<ul style="list-style-type: none"> <li>• Check the connection of the HDMI connectors.</li> <li>• Set the input source to match the connected HDMI connector.</li> <li>• Check whether the TV is compatible with copyright protection (HDCP). If connected to a device not compatible with HDCP, video will not be output correctly.</li> </ul>	<a href="#">9, 10</a> <a href="#">9, 10, 28</a> <a href="#">11</a>
When the following operations are performed on devices compatible with HDMI control, the same operations occur on this unit. <ul style="list-style-type: none"> <li>• Power ON/OFF</li> <li>• Switching audio output devices</li> <li>• Adjust volume</li> <li>• Switch input source</li> </ul>	<ul style="list-style-type: none"> <li>• Set "HDMI Control" in the menu to "Off".</li> </ul> Furthermore, if you do not want to link the power off operation with devices compatible with HDMI control, set "Power Off Control" in the menu to "Off".	<a href="#">88, 108,</a> <a href="#">108</a>



**[Audio]**

Symptom	Cause/Solution	Page
Audio is not output.	<ul style="list-style-type: none"> <li>• Check the connections for all devices.</li> <li>• Check the speaker connections and configurations.</li> <li>• Check whether the audio device power is turned on.</li> <li>• Adjust the master volume.</li> <li>• Cancel the mute mode.</li> <li>• Check the connection with the playback device and select the proper input source.</li> <li>• Match the input mode and the terminal assigned to be the digital input terminal.</li> <li>• Disconnect the headphones. No sound is output from the speakers when headphones are connected.</li> </ul>	<p><a href="#">9, 10, 13, 14, 15, 16, 17, 18, 19, 20</a></p> <p><a href="#">81, 82, 83, 84, 85</a></p> <p>–</p> <p><a href="#">29, 93</a></p> <p><a href="#">29, 93</a></p> <p><a href="#">28, 93</a></p> <p><a href="#">114</a></p> <p><a href="#">130</a></p>
The volume does not increase.	<ul style="list-style-type: none"> <li>• The maximum volume is set too low. Set the maximum volume using "Limit" on the menu.</li> <li>• Power for external devices connected to the output connectors of the unit may not be turned on. Check the power of connected external devices.</li> </ul>	<p><a href="#">104</a></p> <p>–</p>
No sound is produced from surround speakers.	<ul style="list-style-type: none"> <li>• Check if the surround speakers are connected to the SURROUND terminals.</li> </ul>	–
No sound is produced from surround back speakers.	<ul style="list-style-type: none"> <li>• Check if "Assign Mode" is set appropriately in order to output audio from the surround back speakers.</li> <li>• Set "Speaker Config." – "Surr. Back" on the menu to something other than "None".</li> <li>• Set the sound mode to something other than "STEREO" and "VIRTUAL".</li> </ul>	<p><a href="#">116</a></p> <p><a href="#">116</a></p> <p><a href="#">71</a></p>
No sound is produced from front height speakers.	<ul style="list-style-type: none"> <li>• Check if "Assign Mode" is set appropriately in order to output audio from the front height speakers.</li> <li>• Set "Speaker Config." – "Front Height" on the menu to something other than "None".</li> </ul>	<p><a href="#">116</a></p> <p><a href="#">116</a></p>

Symptom	Cause/Solution	Page
No sound is produced from subwoofer.	<ul style="list-style-type: none"> <li>• Check the subwoofer connections.</li> <li>• Turn on the subwoofer's power.</li> <li>• Set "Speaker Config." – "Subwoofer" on the menu to "Yes".</li> <li>• If "Front" and "Center" for "Speaker Config." are set to "Large", and "Subwoofer Mode" is set to "LFE", no sound may be output from the subwoofers, depending on the input signal or selected sound mode.</li> </ul>	<p><a href="#">81, 82, 83, 84, 85</a></p> <p>–</p> <p><a href="#">116</a></p> <p><a href="#">116, 118</a></p>
DTS sound is not output.	<ul style="list-style-type: none"> <li>• Set "Decode Mode" on the menu to "Auto" or "DTS".</li> </ul>	<a href="#">114</a>
Dolby TrueHD, DTS-HD, Dolby Digital Plus audio is not output.	<ul style="list-style-type: none"> <li>• Make HDMI connections.</li> </ul>	<a href="#">9, 10</a>
Dolby PLII mode or DTS NEO:6 mode cannot be selected.	<ul style="list-style-type: none"> <li>• Check that "Speaker Config." – "Center" or "Surround" is set to other than "None". If the speaker system is 2.0/2.1-channel, this sound mode cannot be selected.</li> <li>• When headphones are used, Dolby PLII or DTS NEO:6 cannot be selected.</li> </ul>	<p><a href="#">116</a></p> <p>–</p>
Audyssey MultEQ®, Audyssey Dynamic EQ® and Audyssey Dynamic Volume® cannot be selected.	<ul style="list-style-type: none"> <li>• Switch the sound mode to other than "DIRECT" or "PURE DIRECT".</li> <li>• When headphones are used, Audyssey MultEQ®, Audyssey Dynamic EQ® and Audyssey Dynamic Volume® cannot be selected.</li> </ul>	<p><a href="#">71</a></p> <p>–</p>
Audyssey Dynamic EQ® and Audyssey Dynamic Volume® cannot be selected.	<ul style="list-style-type: none"> <li>• Run Audyssey® Setup.</li> </ul>	<a href="#">21, 86</a>
"Restorer" cannot be selected.	<ul style="list-style-type: none"> <li>• Check that an analog signal or PCM signal (Sample Rate=44.1/48 kHz) is input. For playback of multichannel signals such as Dolby Digital or DTS surround, "Restorer" cannot be used.</li> <li>• Switch the sound mode to other than "DIRECT" or "PURE DIRECT".</li> </ul>	<p><a href="#">103</a></p> <p><a href="#">71</a></p>

**[FM/AM]**

Symptom	Cause/Solution	Page
Reception fails, or there is a lot of noise or distortion.	<ul style="list-style-type: none"> <li>• Change the antenna orientation or position.</li> <li>• Separate the AM loop antenna from the unit.</li> <li>• Use an FM outdoor antenna.</li> <li>• Separate the antenna from other connection cables.</li> </ul>	<a href="#">18</a> <a href="#">18</a> <a href="#">18</a> <a href="#">18</a>





**[iPod / USB memory device / Internet Radio / Media Server / Flickr / Pandora / SiriusXM / Spotify]**

Symptom	Cause/Solution	Page
iPod cannot be played.	<ul style="list-style-type: none"> <li>• Some iPods do not support being used connected directly to the USB port.</li> </ul>	<a href="#">16</a>
The file names are not displayed properly ("...", etc.).	<ul style="list-style-type: none"> <li>• Characters that cannot be displayed are used. This is not a malfunction. On this unit, characters that cannot be displayed are replaced with a "." (period).</li> <li>• Invalid tags are used for files within the USB memory device connected to this unit. Use tags that are supported by this unit.</li> </ul>	– <a href="#">33</a>
When a USB memory device is connected, "No Connection" is displayed.	<ul style="list-style-type: none"> <li>• The set cannot recognize a USB memory device. Check the connection.</li> <li>• This unit supports mass storage class and MTP-compatible USB memory devices. It will not recognize other USB memory devices.</li> <li>• A USB memory device that the set cannot recognize is connected. This is not a malfunction. Denon does not guarantee that all USB memory devices will operate or receive power.</li> <li>• USB memory device is connected via USB hub. Connect the USB memory device directly to the USB port.</li> <li>• The unit supports file structures with up to 8 levels and a total maximum of 5000 subfolders and files per 1 folder. Change the file structure of the USB memory device if necessary.</li> </ul>	<a href="#">16</a> – – – <a href="#">33</a>
Files on a USB memory device cannot be played.	<ul style="list-style-type: none"> <li>• The USB memory device format should be set to FAT16 or FAT32. For details, refer to the USB memory device's operating instructions.</li> <li>• If the USB memory device is divided into multiple partitions, only files in partition one can be played.</li> <li>• Files are stored in a non-compatible format. Record the files in a compatible format.</li> <li>• You are attempting to play a file that is copyright protected. Files that are copyright protected cannot be played on this unit.</li> </ul>	– – <a href="#">33</a> <a href="#">33</a>

Symptom	Cause/Solution	Page
Internet Radio cannot be played.	<ul style="list-style-type: none"> <li>• Ethernet cable is not properly connected or network is disconnected. Check the connection status.</li> <li>• Program is being broadcast in non-compatible format. Only Internet Radio programs in MP3 and WMA can be played on this unit.</li> <li>• The firewall of the PC or router has been activated. Check the firewall settings of the connected PC or router.</li> <li>• Radio station is not currently broadcasting. Choose a radio station that is currently broadcasting.</li> <li>• IP address is wrong. Check the set's IP address.</li> <li>• Some radio stations may go silent at certain times of the day. In this case, no audio is output even when a station is received. Try again later, or switch to another radio station.</li> </ul>	<a href="#">19</a> <a href="#">45</a> – <a href="#">45</a> <a href="#">120</a> –
Files stored on a computer cannot be played.	<ul style="list-style-type: none"> <li>• Files are stored in a non-compatible format. Record in a compatible format.</li> <li>• You are attempting to play a file that is copyright protected. Files that are copyright protected cannot be played on this unit.</li> <li>• Set and computer are connected by USB cable. The set's USB port cannot be used for connection to a computer.</li> <li>• Media sharing settings are not correct. Change media sharing settings so that the unit can access the folders on your computer.</li> </ul>	<a href="#">48</a> <a href="#">48</a> – <a href="#">49</a>
Music stored on a NAS cannot be played.	<ul style="list-style-type: none"> <li>• If you use a NAS in conformity with the DLNA standard, enable the DLNA server function in the NAS setting.</li> <li>• If you use a NAS that does not conform with the DLNA standard, play the music via a PC. Set Windows Media Player's media sharing function and add NAS to the selected play folder.</li> <li>• If connection is restricted, set audio equipment as the connection target.</li> </ul>	– <a href="#">49</a> –
Server is not found, or it is not possible to connect to the server.	<ul style="list-style-type: none"> <li>• The computer's or router's firewall is activated. Check the computer's or router's firewall settings.</li> <li>• Computer's power is not turned on. Turn on the power.</li> <li>• Server is not running. Launch the server.</li> <li>• Set's IP address is wrong. Check the set's IP address.</li> </ul>	– – – <a href="#">120</a>
Cannot connect to preset or favorite radio stations.	<ul style="list-style-type: none"> <li>• Radio station is not currently broadcasting. Wait a while before trying again.</li> <li>• Radio station is not currently in service. It is not possible to connect to radio stations that are no longer in service.</li> </ul>	– –

Symptom	Cause/Solution	Page
A list of broadcasting stations is not displayed.	<ul style="list-style-type: none"> <li>• Connection to the network is unstable. Reconnect to the network or redo the "Network" setting in the menu.</li> </ul>	<a href="#">19</a> , <a href="#">119</a>
For some radio stations, "Radio station server full" or "Connection down" is displayed and station cannot be connected to.	<ul style="list-style-type: none"> <li>• Station is congested or not currently broadcasting. Wait a while before trying again.</li> </ul>	–
Sound is broken during playback.	<ul style="list-style-type: none"> <li>• Network or USB memory device's signal transfer speed is slow or communications lines or radio station is congested. This is not a malfunction. When playing broadcast data with a high bit rate, the sound may be broken, depending on the communications conditions.</li> </ul>	–
Sound quality is poor or noise is heard during play.	<ul style="list-style-type: none"> <li>• File being played has a low bit rate. This is not a malfunction.</li> </ul>	–
Cannot login to Pandora. ("Email address" or "Password" is displayed.)	<ul style="list-style-type: none"> <li>• Login information is incorrect. Check if the "Email address" for Pandora has been properly entered. Re-enter the "Password". (Password is not displayed.) <a href="http://www.pandora.com/denon">http://www.pandora.com/denon</a></li> </ul>	<a href="#">55</a>

#### [AirPlay]

Symptom	Cause/Solution	Page
The AirPlay icon  is not displayed in iTunes or on the iPhone/iPod touch/iPad.	<ul style="list-style-type: none"> <li>• This unit and the computer or iPhone/iPod touch/iPad are not connected to the same network (LAN). Connect the computer or iPhone/iPod touch/iPad to the same network as this unit.</li> <li>• iTunes or the iPhone/iPod touch/iPad do not have firmware that supports AirPlay installed. Update to the latest firmware.</li> </ul>	<a href="#">19</a> –
No sound.	<ul style="list-style-type: none"> <li>• The volume in iTunes or on the iPhone/iPod touch/iPad is set to the minimum setting. Adjust the volume to the optimum level.</li> <li>• This unit is not selected in the screen that is displayed when iTunes or the iPhone/iPod touch/iPad is started. Start iTunes or switch on the iPhone/iPod touch/iPad, click the AirPlay icon  in the displayed screen, and select this unit.</li> <li>• AirPlay playback has not started. Click the  button in iTunes or press the  button on the iPhone/iPod touch/iPad.</li> </ul>	– <a href="#">69</a> –
When using AirPlay with the iPhone/iPod touch/iPad, the sound suffers from intermittent breaks or AirPlay does not function.	<ul style="list-style-type: none"> <li>• Quit the application running in the background of the iPhone/iPod touch/iPad, and then play using AirPlay.</li> <li>• When playing via a wireless connection, outside conditions may affect the unit. To remedy this, change the network environment, e.g. shorten the distance to the wireless LAN access point.</li> <li>• Update the iPhone/iPod touch/iPad application or iTunes to the latest version.</li> </ul>	– – –



#### [Remote control unit]

Symptom	Cause/Solution	Page
The set cannot be operated with the remote control unit.	<ul style="list-style-type: none"> <li>• Batteries are worn out. Replace with new batteries.</li> <li>• Operate the remote control unit within a distance of about 23 ft/7 m from this unit and at an angle of within 30°.</li> <li>• Remove any obstacle between this unit and the remote control unit.</li> <li>• Insert the batteries in the proper direction, checking the ⊕ and ⊖ marks.</li> <li>• The set's remote control sensor is exposed to strong light (direct sunlight, inverter type fluorescent bulb light, etc.). Move the set to a place in which the remote control sensor will not be exposed to strong light.</li> <li>• The setting of the zone to operate does not match. Press <b>MAIN</b> or <b>ZONE2</b> to select the zone to operate.</li> </ul>	<a href="#">134</a> <a href="#">134</a> <a href="#">134</a> <a href="#">134</a> <a href="#">134</a> <a href="#">22</a> , <a href="#">86</a> , <a href="#">93</a>

## Resetting the microprocessor

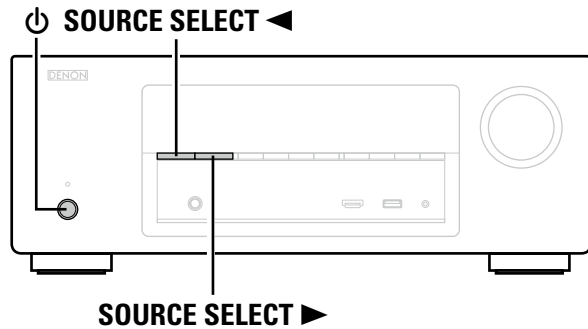
Perform this procedure if the display is abnormal or if operations cannot be performed.  
Note that when the microprocessor is reset, all the settings are reset to their default values.



- 1** Turn off the power using .
- 2** Press  while simultaneously pressing **SOURCE SELECT ◀** and **SOURCE SELECT ▶**.
- 3** Once the display starts flashing at intervals of about 1 second, release the two buttons.



If in step 3 the display does not flash at intervals of about 1 second, start over from step 1.

## Specifications

### Audio section

- **Power amplifier**  
**Rated output:**

Front:  
90 W + 90 W (8 Ω/ohms, 20 Hz – 20 kHz with 0.08 % T.H.D.)  
125 W + 125 W (6 Ω/ohms, 1 kHz with 0.7 % T.H.D.)

Center:  
90 W (8 Ω/ohms, 20 Hz – 20 kHz with 0.08 % T.H.D.)  
125 W (6 Ω/ohms, 1 kHz with 0.7 % T.H.D.)

Surround:  
90 W + 90 W (8 Ω/ohms, 20 Hz – 20 kHz with 0.08 % T.H.D.)  
125 W + 125 W (6 Ω/ohms, 1 kHz with 0.7 % T.H.D.)

Surround back:  
90 W + 90 W (8 Ω/ohms, 20 Hz – 20 kHz with 0.08 % T.H.D.)  
125 W + 125 W (6 Ω/ohms, 1 kHz with 0.7 % T.H.D.)  
6 – 16 Ω/ohms

#### Output connectors:

- **Analog**

**Input sensitivity/Input impedance:**

200 mV/47 kΩ/kohms

**Frequency response:**

10 Hz – 100 kHz — +1, –3 dB (DIRECT mode)

**S/N:**

100 dB (IHF–A weighted, DIRECT mode)

### Tuner section

**Receiving Range:**

	[FM]	[AM]
(Note: μV at 75 Ω/ohms, 0 dBf = 1 × 10 <sup>-15</sup> W)	87.5 MHz – 107.9 MHz	520 kHz – 1710 kHz
<b>Usable Sensitivity:</b>	1.2 μV (12.8 dBf)	18 μV

**50 dB Quieting Sensitivity:**

MONO 2.8 μV (20.2 dBf)

**S/N :**

MONO 70 dB (IHF–A weighted, DIRECT mode)

STEREO 67 dB (IHF–A weighted, DIRECT mode)

**Total harmonic Distortion:**

MONO 0.7 % (1 kHz)

STEREO 1.0 % (1 kHz)

### General

**Power supply:**

AC 120 V, 60 Hz

**Power consumption:**

460 W

**Power consumption in standby mode:**

0.1 W

**Power consumption in CEC standby mode:**

0.5 W

**Power consumption in network standby mode:**

2.7 W

For purposes of improvement, specifications and design are subject to change without notice.

## Index

### Numerics

2.1-channel	85
3D	11
4K	11
5.1-channel	78, 84
6.1-channel	78, 83
7.1-channel	77, 78, 81, 82

### A

Accessories	2
Add New Feature	128
Adjust EQ	105
Adjusting the master volume	29
Adobe RGB color / Adobe YCC601 color	142
AirPlay	69, 142
ALAC	142
All Zone Stereo	68
AM loop antenna	18
Amp Assign	116
App Store	142
ARC	8
Aspect Ratio	109
Audio	100
Audio Delay	103
Audyssey	104
Audyssey Dynamic EQ®	105, 142
Audyssey Dynamic Volume®	105, 142
Audyssey MultEQ®	104, 142
Audyssey® Setup	21, 86
Auto Lip Sync	107, 142
Auto Preset Memory	41
Auto Standby	125

### B

Bass	103, 118
Brightness	107

### C

Cable	
Audio cable	12
Coaxial digital cable	12
Component video cable	12
Ethernet cable	12
HDMI cable	9, 10
Optical cable	12
Speaker cable	79
Subwoofer cable	79
Video cable	12
Center Gain	102
Center Width	102
Characters	99
Check Results	27
Cinema EQ	101
Condensation	3
Connection	
Blu-ray Disc player	10
Cable TV	14
CD player	17
DVD player	10, 15
FM/AM	18
Game console	10
HDMI	7
Home network (LAN)	19
iPod (USB)	16
Media player	10
Power cord	20
Satellite tuner	14
Set-top box	10, 14
Speaker	79
TV	9, 13
USB memory device	16
Video camcorder	10
Content Type	11
Contrast	107
Crossovers	118
Curve Copy	105

### D

Decode Mode	114
Deep Color	11, 142
Delay Time	102
Diagnostics	122
Dialog Level	101
Dimension	102
Dimmer	125
Direct Tune	38
Display	131
Distances	117
DLNA	142
Dolby	
Dolby Digital	74, 142
Dolby Digital EX	74, 142
Dolby Digital Plus	74, 142
Dolby Pro Logic II	74, 142
Dolby Pro Logic IIx	74, 142
Dolby Pro Logic IIz	74, 77, 142
Dolby TrueHD	74, 142
Downmix	142
DTS	142
DTS 96/24	74, 142
DTS Digital Surround	142
DTS-ES Discrete 6.1	74, 142
DTS-ES Matrix 6.1	74, 142
DTS Express	74, 143
DTS-HD	74, 143
DTS-HD High Resolution Audio	143
DTS-HD Master Audio	143
DTS Neo:6	74, 77
DTS NEO:6™ Surround	143
Dynamic Compression	101
Dynamic EQ	105
Dynamic range	143
Dynamic Volume	105

### E

Edit Name	120
Effect Level	102
Enhancer	107
Error messages (Audyssey® Setup)	26

### F

Firmware	127
FLAC	143
Flicker	52, 53
FM/AM	36
FM indoor antenna	18
Format	110
Friendly Name	120
Front Display	125
Front Height	116
Front height speaker	77, 82
Front Panel	130

### G

General	123
Graphic EQ	105

### H

HDCP	11, 143
HDMI	7, 11, 143
HDMI Audio Out	107
HDMI Control	108
HDMI control function	88
HDMI Pass Through	107
HDMI Setup	107
Headphones	130
Height Gain	102
Hide Sources	114
Hue	107

### I

Info	110
Information	120, 126
Audio	126
Firmware	126
Notifications	126
Video	126
ZONE	126
Input Assign	112
Input Mode	114
Inputs	111
Input Select	114
Input signal	138
Inputting characters	99
Internet Access	122
IP Control	120
iPod Browse Mode	31
i/p Scaler	109
iTunes	143

<b>L</b>	
Language	124
Lch Level	124
Levels	117
LFE	143
Limit	104
Listening mode	71
Listening position	21
Lock	128
Loudness Management	101
Low Frequency Effects	102
<b>M</b>	
MAIN ZONE	143
Manual Setup	116
Menu map	95
Mode	103
MP3	143
MPEG	143
MultEQ®	104
Mute Level	104, 124
<b>N</b>	
Network	27, 119
Noise Reduction	107
Notifications	127
Now Playing	110
<b>O</b>	
On Screen Display	110
Output Settings	108
<b>P</b>	
Pandora®	52, 55
Panorama	102
Pass Through Source	108
Physical Connection	122
Picture Adjust	107
Picture Mode	67, 107
Playback	
ALAC	33, 48
Blu-ray Disc player	29
CD player	29
Direct	71, 75
DVD player	29
FLAC	33, 48
Flickr	53

FM/AM	36
Internet Radio	45
iPod (USB)	30
JPEG	33, 48
MP3	33, 45, 48
MPEG-4 AAC	33, 48
NAS	48
Original listening mode	75
Pandora®	55
PC	48
Pure Direct	71, 75
SiriusXM	59
Spotify	61
Stereo	75
USB memory device	33
WAV	33, 48
WMA	33, 45, 48
ZONE2	93
Power Off Control	108
Power On Level	104
Power On Volume	124
Preset Memory	39
Preset Name	42
Preset Skip	43
Progressive	143
Progressive Mode	109
Protection circuit	143
<b>Q</b>	
Quick select function	90
Quick Select Names	125
<b>R</b>	
Random	32, 64
Rch Level	124
Rear panel	132
Reference Level Offset	105
Remote control unit	133
Inserting the batteries	134
Remove from Favorites	66
Repeat	32, 63
Resetting the microprocessor	149
Resolution	109
Restorer	103
Room Size	102
Router Access	122

<b>S</b>	
Sampling frequency	143
Saturation	107
Save to Favorites	65
Scale	104
Selecting the input source	28
Settings	121
Setup Lock	128
SiriusXM	52, 59
Sleep timer	89, 94
Slideshow	66
Slideshow Interval	66
Sound Mode	71, 136
Source Level	114
Source Rename	114
Speaker	
Connect	79
Install	77
Set up	21, 86
Speaker Config.	116
Speaker impedance	79, 143
Speakers	115
Speaker Selection	105
Spotify	52, 61
Subwoofer	101
Subwoofer Level	101
Subwoofer setting	22
Surr. Back	116
Surround back speaker	77, 78, 81, 83
Surround Parameter	101
sYCC601 color	143
<b>T</b>	
Text Search	63
Tone	103
Tone Control	103
Trademark	135
Treble	103
Troubleshooting	145
Tune Mode	40
Turning off the sound temporarily	29
Turning the power on	28
TV Format	110

<b>U</b>	
Update	127
Usage Data	127

<b>V</b>	
Video	106
Video conversion	6
Video Conversion	108
Video Mode	108
Video Select	67
Volume	104, 110
Volume Level	124
Volume Limit	124
vTuner	47, 143

<b>W</b>	
Web control	91
Windows Media DRM	144
Windows Media Player	144
WMA	144

<b>X</b>	
x.v.Color	144

<b>Z</b>	
ZONE2	93, 131, 144
ZONE2 Setup	124
Zone mode setting	22, 86
Zone Rename	124



## License

**This section describes software license used for this unit. To maintain the correct content, the original (English) is used.**

### □ Boost

<http://www.boost.org/>

Boost Software License - Version 1.0 - August 17th, 2003

Permission is hereby granted, free of charge, to any person or organization obtaining a copy of the software and accompanying documentation covered by this license (the "Software") to use, reproduce, display, distribute, execute, and transmit the Software, and to prepare derivative works of the Software, and to permit third-parties to whom the Software is furnished to do so, all subject to the following:

The copyright notices in the Software and this entire statement, including the above license grant, this restriction and the following disclaimer, must be included in all copies of the Software, in whole or in part, and all derivative works of the Software, unless such copies or derivative works are solely in the form of machine-executable object code generated by a source language processor.

THE SOFTWARE IS PROVIDED "AS IS", WITHOUT WARRANTY OF ANY KIND, EXPRESS OR IMPLIED, INCLUDING BUT NOT LIMITED TO THE WARRANTIES OF MERCHANTABILITY, FITNESS FOR A PARTICULAR PURPOSE, TITLE AND NON-INFRINGEMENT. IN NO EVENT SHALL THE COPYRIGHT HOLDERS OR ANYONE DISTRIBUTING THE SOFTWARE BE LIABLE FOR ANY DAMAGES OR OTHER LIABILITY, WHETHER IN CONTRACT, TORT OR OTHERWISE, ARISING FROM, OUT OF OR IN CONNECTION WITH THE SOFTWARE OR THE USE OR OTHER DEALINGS IN THE SOFTWARE.

### □ Expat

<http://www.jclark.com/xml/expat.html>

Expat License. Copyright (c) 1998, 1999, 2000 Thai Open Source Software Center Ltd

Permission is hereby granted, free of charge, to any person obtaining a copy of this software and associated documentation files (the "Software"), to deal in the Software without restriction, including without limitation the rights to use, copy, modify, merge, publish, distribute, sublicense, and/or sell copies of the Software, and to permit persons to whom the Software is furnished to do so, subject to the following conditions:

The above copyright notice and this permission notice shall be included in all copies or substantial portions of the Software.

THE SOFTWARE IS PROVIDED "AS IS", WITHOUT WARRANTY OF ANY KIND, EXPRESS OR IMPLIED, INCLUDING BUT NOT LIMITED TO THE WARRANTIES OF MERCHANTABILITY, FITNESS FOR A PARTICULAR PURPOSE AND NON-INFRINGEMENT. IN NO EVENT SHALL THE AUTHORS OR COPYRIGHT HOLDERS BE LIABLE FOR ANY CLAIM, DAMAGES OR OTHER LIABILITY, WHETHER IN AN ACTION OF CONTRACT, TORT OR OTHERWISE, ARISING FROM, OUT OF OR IN CONNECTION WITH THE SOFTWARE OR THE USE OR OTHER DEALINGS IN THE SOFTWARE.

### □ FastDelegate

<http://www.codeproject.com/KB/cpp/FastDelegate.aspx>

THE WORK (AS DEFINED BELOW) IS PROVIDED UNDER THE TERMS OF THIS CODE PROJECT OPEN LICENSE ("LICENSE"). THE WORK IS PROTECTED BY COPYRIGHT AND/OR OTHER APPLICABLE LAW. ANY USE OF THE WORK OTHER THAN AS AUTHORIZED UNDER THIS LICENSE OR COPYRIGHT LAW IS PROHIBITED.

BY EXERCISING ANY RIGHTS TO THE WORK PROVIDED HEREIN, YOU ACCEPT AND AGREE TO BE BOUND BY THE TERMS OF THIS LICENSE. THE AUTHOR GRANTS YOU THE RIGHTS CONTAINED HEREIN IN CONSIDERATION OF YOUR ACCEPTANCE OF SUCH TERMS AND CONDITIONS. IF YOU DO NOT AGREE TO ACCEPT AND BE BOUND BY THE TERMS OF THIS LICENSE, YOU CANNOT MAKE ANY USE OF THE WORK.

- Definitions.
  - "Articles" means, collectively, all articles written by Author which describes how the Source Code and Executable Files for the Work may be used by a user.
  - "Author" means the individual or entity that offers the Work under the terms of this License.
  - "Derivative Work" means a work based upon the Work or upon the Work and other pre-existing works.
  - "Executable Files" refer to the executables, binary files, configuration and any required data files included in the Work.
  - "Publisher" means the provider of the website, magazine, CD-ROM, DVD or other medium from or by which the Work is obtained by You.
  - "Source Code" refers to the collection of source code and configuration files used to create the Executable Files.
  - "Standard Version" refers to such a Work if it has not been modified, or has been modified in accordance with the consent of the Author, such consent being in the full discretion of the Author.
  - "Work" refers to the collection of files distributed by the Publisher, including the Source Code, Executable Files, binaries, data files, documentation, whitepapers and the Articles.
  - "You" is you, an individual or entity wishing to use the Work and exercise your rights under this License.
- Fair Use/Fair Use Rights. Nothing in this License is intended to reduce, limit, or restrict any rights arising from fair use, fair dealing, first sale or other limitations on the exclusive rights of the copyright owner under copyright law or other applicable laws.

- License Grant. Subject to the terms and conditions of this License, the Author hereby grants You a worldwide, royalty-free, non-exclusive, perpetual (for the duration of the applicable copyright) license to exercise the rights in the Work as stated below:
  - You may use the standard version of the Source Code or Executable Files in Your own applications.
  - You may apply bug fixes, portability fixes and other modifications obtained from the Public Domain or from the Author. A Work modified in such a way shall still be considered the standard version and will be subject to this License.
  - You may otherwise modify Your copy of this Work (excluding the Articles) in any way to create a Derivative Work, provided that You insert a prominent notice in each changed file stating how, when and where You changed that file.
  - You may distribute the standard version of the Executable Files and Source Code or Derivative Work in aggregate with other (possibly commercial) programs as part of a larger (possibly commercial) software distribution.
  - The Articles discussing the Work published in any form by the author may not be distributed or republished without the Author's consent. The author retains copyright to any such Articles. You may use the Executable Files and Source Code pursuant to this License but you may not repost or republish or otherwise distribute or make available the Articles, without the prior written consent of the Author.
- Any subroutines or modules supplied by You and linked into the Source Code or Executable Files this Work shall not be considered part of this Work and will not be subject to the terms of this License.
- Patent License. Subject to the terms and conditions of this License, each Author hereby grants to You a perpetual, worldwide, non-exclusive, no-charge, royalty-free, irrevocable (except as stated in this section) patent license to make, have made, use, import, and otherwise transfer the Work.
- Restrictions. The license granted in Section 3 above is expressly made subject to and limited by the following restrictions:
  - You agree not to remove any of the original copyright, patent, trademark, and attribution notices and associated disclaimers that may appear in the Source Code or Executable Files.
  - You agree not to advertise or in any way imply that this Work is a product of Your own.
  - The name of the Author may not be used to endorse or promote products derived from the Work without the prior written consent of the Author.
  - You agree not to sell, lease, or rent any part of the Work. This does not restrict you from including the Work or any part of the Work inside a larger software distribution that itself is being sold. The Work by itself, though, cannot be sold, leased or rented.

- You may distribute the Executable Files and Source Code only under the terms of this License, and You must include a copy of, or the Uniform Resource Identifier for, this License with every copy of the Executable Files or Source Code You distribute and ensure that anyone receiving such Executable Files and Source Code agrees that the terms of this License apply to such Executable Files and/or Source Code. You may not offer or impose any terms on the Work that alter or restrict the terms of this License or the recipients' exercise of the rights granted hereunder. You may not sublicense the Work. You must keep intact all notices that refer to this License and to the disclaimer of warranties. You may not distribute the Executable Files or Source Code with any technological measures that control access or use of the Work in a manner inconsistent with the terms of this License.
  - You agree not to use the Work for illegal, immoral or improper purposes, or on pages containing illegal, immoral or improper material. The Work is subject to applicable export laws. You agree to comply with all such laws and regulations that may apply to the Work after Your receipt of the Work.
- Representations, Warranties and Disclaimer. THIS WORK IS PROVIDED "AS IS", "WHERE IS" AND "AS AVAILABLE", WITHOUT ANY EXPRESS OR IMPLIED WARRANTIES OR CONDITIONS OR GUARANTEES. YOU, THE USER, ASSUME ALL RISK IN ITS USE, INCLUDING COPYRIGHT INFRINGEMENT, PATENT INFRINGEMENT, SUITABILITY, ETC. AUTHOR EXPRESSLY DISCLAIMS ALL EXPRESS, IMPLIED OR STATUTORY WARRANTIES OR CONDITIONS, INCLUDING WITHOUT LIMITATION, WARRANTIES OR CONDITIONS OF MERCHANTABILITY, MERCHANTABILITY QUALITY OR FITNESS FOR A PARTICULAR PURPOSE, OR ANY WARRANTY OF TITLE OR NON-INFRINGEMENT, OR THAT THE WORK (OR ANY PORTION THEREOF) IS CORRECT, USEFUL, BUG-FREE OR FREE OF VIRUSES. YOU MUST PASS THIS DISCLAIMER ON WHENEVER YOU DISTRIBUTE THE WORK OR DERIVATIVE WORKS.
  - Indemnity. You agree to defend, indemnify and hold harmless the Author and the Publisher from and against any claims, suits, losses, damages, liabilities, costs, and expenses (including reasonable legal or attorneys' fees) resulting from or relating to any use of the Work by You.
  - Limitation on Liability. EXCEPT TO THE EXTENT REQUIRED BY APPLICABLE LAW, IN NO EVENT WILL THE AUTHOR OR THE PUBLISHER BE LIABLE TO YOU ON ANY LEGAL THEORY FOR ANY SPECIAL, INCIDENTAL, CONSEQUENTIAL, PUNITIVE OR EXEMPLARY DAMAGES ARISING OUT OF THIS LICENSE OR THE USE OF THE WORK OR OTHERWISE, EVEN IF THE AUTHOR OR THE PUBLISHER HAS BEEN ADVISED OF THE POSSIBILITY OF SUCH DAMAGES.

9. Termination.

- a. This License and the rights granted hereunder will terminate automatically upon any breach by You of any term of this License. Individuals or entities who have received Derivative Works from You under this License, however, will not have their licenses terminated provided such individuals or entities remain in full compliance with those licenses. Sections 1, 2, 6, 7, 8, 9, 10 and 11 will survive any termination of this License.
  - b. If You bring a copyright, trademark, patent or any other infringement claim against any contributor over infringements You claim are made by the Work, your License from such contributor to the Work ends automatically.
  - c. Subject to the above terms and conditions, this License is perpetual (for the duration of the applicable copyright in the Work). Notwithstanding the above, the Author reserves the right to release the Work under different license terms or to stop distributing the Work at any time; provided, however that any such election will not serve to withdraw this License (or any other license that has been, or is required to be, granted under the terms of this License), and this License will continue in full force and effect unless terminated as stated above.
10. Publisher. The parties hereby confirm that the Publisher shall not, under any circumstances, be responsible for and shall not have any liability in respect of the subject matter of this License. The Publisher makes no warranty whatsoever in connection with the Work and shall not be liable to You or any party on any legal theory for any damages whatsoever, including without limitation any general, special, incidental or consequential damages arising in connection to this license. The Publisher reserves the right to cease making the Work available to You at any time without notice
11. Miscellaneous
- a. This License shall be governed by the laws of the location of the head office of the Author or if the Author is an individual, the laws of location of the principal place of residence of the Author.
  - b. If any provision of this License is invalid or unenforceable under applicable law, it shall not affect the validity or enforceability of the remainder of the terms of this License, and without further action by the parties to this License, such provision shall be reformed to the minimum extent necessary to make such provision valid and enforceable.
  - c. No term or provision of this License shall be deemed waived and no breach consented to unless such waiver or consent shall be in writing and signed by the party to be charged with such waiver or consent.
  - d. This License constitutes the entire agreement between the parties with respect to the Work licensed herein. There are no understandings, agreements or representations with respect to the Work not specified herein. The Author shall not be bound by any additional provisions that may appear in any communication from You. This License may not be modified without the mutual written agreement of the Author and You.

## libogg

<http://www.xiph.org/ogg/>

Copyright (c) 2002, Xiph.org Foundation

Redistribution and use in source and binary forms, with or without modification, are permitted provided that the following conditions are met:

- Redistributions of source code must retain the above copyright notice, this list of conditions and the following disclaimer.
- Redistributions in binary form must reproduce the above copyright notice, this list of conditions and the following disclaimer in the documentation and/or other materials provided with the distribution.
- Neither the name of the Xiph.org Foundation nor the names of its contributors may be used to endorse or promote products derived from this software without specific prior written permission.

THIS SOFTWARE IS PROVIDED BY THE COPYRIGHT HOLDERS AND CONTRIBUTORS "AS IS" AND ANY EXPRESS OR IMPLIED WARRANTIES, INCLUDING, BUT NOT LIMITED TO, THE IMPLIED WARRANTIES OF MERCHANTABILITY AND FITNESS FOR A PARTICULAR PURPOSE ARE DISCLAIMED. IN NO EVENT SHALL THE FOUNDATION OR CONTRIBUTORS BE LIABLE FOR ANY DIRECT, INDIRECT, INCIDENTAL, SPECIAL, EXEMPLARY, OR CONSEQUENTIAL DAMAGES (INCLUDING, BUT NOT LIMITED TO, PROCUREMENT OF SUBSTITUTE GOODS OR SERVICES; LOSS OF USE, DATA, OR PROFITS; OR BUSINESS INTERRUPTION) HOWEVER CAUSED AND ON ANY THEORY OF LIABILITY, WHETHER IN CONTRACT, STRICT LIABILITY, OR TORT (INCLUDING NEGLIGENCE OR OTHERWISE) ARISING IN ANY WAY OUT OF THE USE OF THIS SOFTWARE, EVEN IF ADVISED OF THE POSSIBILITY OF SUCH DAMAGE.

## libvorbis

<http://www.xiph.org/vorbis/>

Copyright (c) 2002-2004 Xiph.org Foundation

Redistribution and use in source and binary forms, with or without modification, are permitted provided that the following conditions are met:

- Redistributions of source code must retain the above copyright notice, this list of conditions and the following disclaimer.
- Redistributions in binary form must reproduce the above copyright notice, this list of conditions and the following disclaimer in the documentation and/or other materials provided with the distribution.
- Neither the name of the Xiph.org Foundation nor the names of its contributors may be used to endorse or promote products derived from this software without specific prior written permission.

THIS SOFTWARE IS PROVIDED BY THE COPYRIGHT HOLDERS AND CONTRIBUTORS "AS IS" AND ANY EXPRESS OR IMPLIED WARRANTIES, INCLUDING, BUT NOT LIMITED TO, THE IMPLIED WARRANTIES OF MERCHANTABILITY AND FITNESS FOR A PARTICULAR PURPOSE ARE DISCLAIMED. IN NO EVENT SHALL THE FOUNDATION OR CONTRIBUTORS BE LIABLE FOR ANY DIRECT, INDIRECT, INCIDENTAL, SPECIAL, EXEMPLARY, OR CONSEQUENTIAL DAMAGES (INCLUDING, BUT NOT LIMITED TO, PROCUREMENT OF SUBSTITUTE GOODS OR SERVICES; LOSS OF USE, DATA, OR PROFITS; OR BUSINESS INTERRUPTION) HOWEVER CAUSED AND ON ANY THEORY OF LIABILITY, WHETHER IN CONTRACT, STRICT LIABILITY, OR TORT (INCLUDING NEGLIGENCE OR OTHERWISE) ARISING IN ANY WAY OUT OF THE USE OF THIS SOFTWARE, EVEN IF ADVISED OF THE POSSIBILITY OF SUCH DAMAGE.

## Tremolo

<http://wss.co.uk/pinknoise/tremolo>

Copyright (C) 2002-2009 Xiph.org Foundation  
Copyright (C) 2009-2010 Robin Watts for Pinknoise Productions Ltd

Redistribution and use in source and binary forms, with or without modification, are permitted provided that the following conditions are met:

- Redistributions of source code must retain the above copyright notice, this list of conditions and the following disclaimer.
- Redistributions in binary form must reproduce the above copyright notice, this list of conditions and the following disclaimer in the documentation and/or other materials provided with the distribution.
- Neither the name of the Xiph.org Foundation nor the names of its contributors may be used to endorse or promote products derived from this software without specific prior written permission.

THIS SOFTWARE IS PROVIDED BY THE COPYRIGHT HOLDERS AND CONTRIBUTORS "AS IS" AND ANY EXPRESS OR IMPLIED WARRANTIES, INCLUDING, BUT NOT LIMITED TO, THE IMPLIED WARRANTIES OF MERCHANTABILITY AND FITNESS FOR A PARTICULAR PURPOSE ARE DISCLAIMED. IN NO EVENT SHALL THE FOUNDATION OR CONTRIBUTORS BE LIABLE FOR ANY DIRECT, INDIRECT, INCIDENTAL, SPECIAL, EXEMPLARY, OR CONSEQUENTIAL DAMAGES (INCLUDING, BUT NOT LIMITED TO, PROCUREMENT OF SUBSTITUTE GOODS OR SERVICES; LOSS OF USE, DATA, OR PROFITS; OR BUSINESS INTERRUPTION) HOWEVER CAUSED AND ON ANY THEORY OF LIABILITY, WHETHER IN CONTRACT, STRICT LIABILITY, OR TORT (INCLUDING NEGLIGENCE OR OTHERWISE) ARISING IN ANY WAY OUT OF THE USE OF THIS SOFTWARE, EVEN IF ADVISED OF THE POSSIBILITY OF SUCH DAMAGE.

## Tremor

<http://wiki.xiph.org/index.php/Tremor>

Copyright (c) 2002, Xiph.org Foundation

Redistribution and use in source and binary forms, with or without modification, are permitted provided that the following conditions are met:

- Redistributions of source code must retain the above copyright notice, this list of conditions and the following disclaimer.
- Redistributions in binary form must reproduce the above copyright notice, this list of conditions and the following disclaimer in the documentation and/or other materials provided with the distribution.
- Neither the name of the Xiph.org Foundation nor the names of its contributors may be used to endorse or promote products derived from this software without specific prior written permission.

THIS SOFTWARE IS PROVIDED BY THE COPYRIGHT HOLDERS AND CONTRIBUTORS "AS IS" AND ANY EXPRESS OR IMPLIED WARRANTIES, INCLUDING, BUT NOT LIMITED TO, THE IMPLIED WARRANTIES OF MERCHANTABILITY AND FITNESS FOR A PARTICULAR PURPOSE ARE DISCLAIMED. IN NO EVENT SHALL THE FOUNDATION OR CONTRIBUTORS BE LIABLE FOR ANY DIRECT, INDIRECT, INCIDENTAL, SPECIAL, EXEMPLARY, OR CONSEQUENTIAL DAMAGES (INCLUDING, BUT NOT LIMITED TO, PROCUREMENT OF SUBSTITUTE GOODS OR SERVICES; LOSS OF USE, DATA, OR PROFITS; OR BUSINESS INTERRUPTION) HOWEVER CAUSED AND ON ANY THEORY OF LIABILITY, WHETHER IN CONTRACT, STRICT LIABILITY, OR TORT (INCLUDING NEGLIGENCE OR OTHERWISE) ARISING IN ANY WAY OUT OF THE USE OF THIS SOFTWARE, EVEN IF ADVISED OF THE POSSIBILITY OF SUCH DAMAGE.

## Mersenne Twister

<http://www.math.sci.hiroshima-u.ac.jp/~m-mat/MT/MT2002/CODES/mt19937ar.c>

Copyright (C) 1997 - 2002, Makoto Matsumoto and Takuji Nishimura,  
All rights reserved.

Redistribution and use in source and binary forms, with or without modification, are permitted provided that the following conditions are met:

1. Redistributions of source code must retain the above copyright notice, this list of conditions and the following disclaimer.
2. Redistributions in binary form must reproduce the above copyright notice, this list of conditions and the following disclaimer in the documentation and/or other materials provided with the distribution.



- The names of its contributors may not be used to endorse or promote products derived from this software without specific prior written permission.

THIS SOFTWARE IS PROVIDED BY THE COPYRIGHT HOLDERS AND CONTRIBUTORS "AS IS" AND ANY EXPRESS OR IMPLIED WARRANTIES, INCLUDING, BUT NOT LIMITED TO, THE IMPLIED WARRANTIES OF MERCHANTABILITY AND FITNESS FOR A PARTICULAR PURPOSE ARE DISCLAIMED. IN NO EVENT SHALL THE COPYRIGHT OWNER OR CONTRIBUTORS BE LIABLE FOR ANY DIRECT, INDIRECT, INCIDENTAL, SPECIAL, EXEMPLARY, OR CONSEQUENTIAL DAMAGES (INCLUDING, BUT NOT LIMITED TO, PROCUREMENT OF SUBSTITUTE GOODS OR SERVICES; LOSS OF USE, DATA, OR PROFITS; OR BUSINESS INTERRUPTION) HOWEVER CAUSED AND ON ANY THEORY OF LIABILITY, WHETHER IN CONTRACT, STRICT LIABILITY, OR TORT (INCLUDING NEGLIGENCE OR OTHERWISE) ARISING IN ANY WAY OUT OF THE USE OF THIS SOFTWARE, EVEN IF ADVISED OF THE POSSIBILITY OF SUCH DAMAGE.

### **zlib**

<http://www.zlib.net/>

zlib.h – interface of the 'zlib' general purpose compression library version 1.2.3, July 18th, 2005

Copyright (C) 1995-2004 Jean-loup Gailly and Mark Adler

This software is provided 'as-is', without any express or implied warranty. In no event will the authors be held liable for any damages arising from the use of this software.

Permission is granted to anyone to use this software for any purpose, including commercial applications, and to alter it and redistribute it freely, subject to the following restrictions:

- The origin of this software must not be misrepresented; you must not claim that you wrote the original software. If you use this software in a product, an acknowledgment in the product documentation would be appreciated but is not required.
- Altered source versions must be plainly marked as such, and must not be misrepresented as being the original software.
- This notice may not be removed or altered from any source distribution.

Jean-loup Gailly [jloup@gzip.org](mailto:jloup@gzip.org), Mark Adler [madler@alumni.caltech.edu](mailto:madler@alumni.caltech.edu)

### **cURL**

<http://curl.haxx.se>

#### COPYRIGHT AND PERMISSION NOTICE

Copyright (c) 1996 - 2011, Daniel Stenberg, <[daniel@haxx.se](mailto:daniel@haxx.se)>.

All rights reserved.

Permission to use, copy, modify, and distribute this software for any purpose with or without fee is hereby granted, provided that the above copyright notice and this permission notice appear in all copies.

THE SOFTWARE IS PROVIDED "AS IS", WITHOUT WARRANTY OF ANY KIND, EXPRESS OR IMPLIED, INCLUDING BUT NOT LIMITED TO THE WARRANTIES OF MERCHANTABILITY, FITNESS FOR A PARTICULAR PURPOSE AND NONINFRINGEMENT OF THIRD PARTY RIGHTS. IN NO EVENT SHALL THE AUTHORS OR COPYRIGHT HOLDERS BE LIABLE FOR ANY CLAIM, DAMAGES OR OTHER LIABILITY, WHETHER IN AN ACTION OF CONTRACT, TORT OR OTHERWISE, ARISING FROM, OUT OF OR IN CONNECTION WITH THE SOFTWARE OR THE USE OR OTHER DEALINGS IN THE SOFTWARE.

Except as contained in this notice, the name of a copyright holder shall not be used in advertising or otherwise to promote the sale, use or other dealings in this Software without prior written authorization of the copyright holder.

### **c-ares**

<http://c-ares.haxx.se>

Copyright 1998 by the Massachusetts Institute of Technology.

Permission to use, copy, modify, and distribute this software and its documentation for any purpose and without fee is hereby granted, provided that the above copyright notice appear in all copies and that both that copyright notice and this permission notice appear in supporting documentation, and that the name of M.I.T. not be used in advertising or publicity pertaining to distribution of the software without specific, written prior permission. M.I.T. makes no representations about the suitability of this software for any purpose. It is provided "as is" without express or implied warranty.

## License Information for the Software Used in the Unit

### About GPL (GNU-General Public License), LGPL (GNU Lesser General Public License) License

This product uses GPL/LGPL software and software made by other companies.

After you purchase this product, you may procure, modify or distribute the source code of the GPL/LGPL software that is used in the product.

Denon provides the source code based on the GPL and LGPL licenses at the actual cost upon your request to our customer service center. However, note that we make no guarantees concerning the source code. Please also understand that we do not offer support for the contents of the source code.

# Dimensions

Unit : in. (mm)

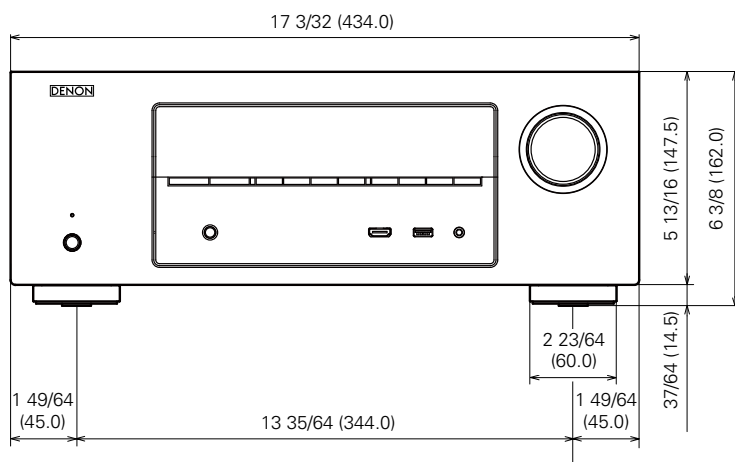
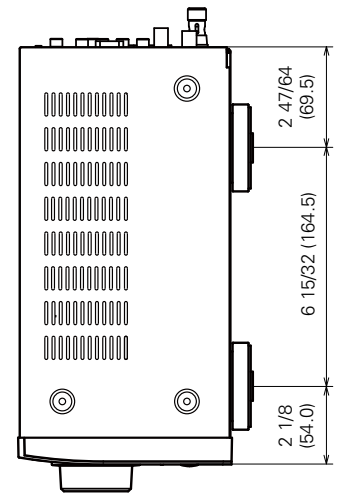
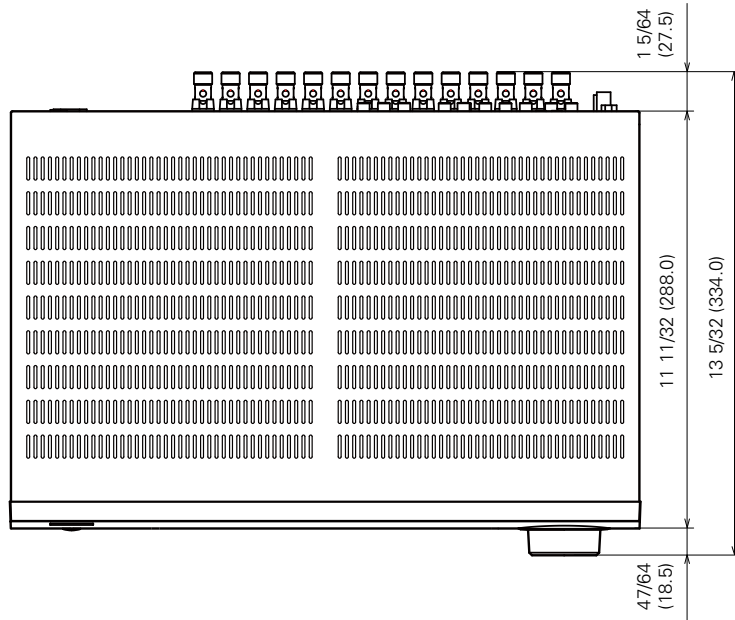

**Weight : 20 lbs 12 oz (9.4 kg)**

